



City of Vancouver *Land Use and Development Policies and Guidelines*

Planning, Urban Design and Sustainability Department

453 West 12th Avenue, Vancouver, BC V5Y 1V4 | tel: 3-1-1, outside Vancouver 604.873.7000 | fax: 604.873.7100
website: vancouver.ca | email: planning@vancouver.ca | app: VanConnect

DOWNTOWN SOUTH GUIDELINES (excluding Granville Street)

Adopted by City Council on July 30, 1991

Amended September 29, 1994, October 7, 1997, June 10, 2004 and September 10, 2019

DOWNTOWN SOUTH GUIDELINES

A manual outlining details and specifications for the streetscape design is available from the Engineering Department.

Contents

	Page
1	Application and Intent 1
2	General Design Considerations 2
2.1/2.2	Neighbourhood and Streetscape Character 2
2.3	Orientation 4
2.4	Views 4
2.6	Light and Ventilation 4
2.7	Weather Protection 5
2.8	Noise 5
2.9	Privacy 6
2.10	Safety and Security 6
2.12	Heritage 9
3	Uses 9
4	Height, Setback, Parking and Horizontal Angle of Daylight Guidelines 9
4.1	Height and Massing 9
4.2	Setbacks 13
4.3	Floor Space Ratio 16
4.4	Off-Street Parking and Loading 16
4.5	Horizontal Angle of Daylight 17
5	Architectural Components 18
5.1	Roofs 18
5.3	Entrances 19
5.4	Balconies 20
5.5	Exterior Walls and Finishing 21
5.6	Awnings, Canopies, Recesses and Arcades 24
5.7	Lighting 25
7	Open Space 25
7.1	Public Open Space 25
7.2	Semi-Private Open Space 25
7.3	Private Open Space 26
8	Landscaping 26
8.1	Streetscape - All Areas Except Davie Street and Pacific Boulevard 26
8.2	Streetscape - Retail Areas (Davie Street) 37
8.3	Streetscape - Pacific Boulevard 40

Note: These guidelines are organized under standard headings. As a consequence, there are gaps in the numbering sequence where no guidelines apply.

Application and Intent

These guidelines are to be used with the **Downtown Official Development Plan** for approval of uses or discretionary variations in regulations within the New Yaletown, Hornby Slopes, and Burrard-Granville areas of Downtown South (Figure 1). The guidelines describe design opportunities and should assist designers of projects. They will also be used by City staff in evaluating development proposals.

The streetscape section of these guidelines is to be used in conjunction with a manual available from the Streets Division, Engineering Services.

The general intent of these guidelines is to assist in the creation of a distinct urban character for Downtown South; to encourage energy efficiency through site planning and building design; to ensure a high standard of livability for residential projects and the area as a whole; and to ensure high quality development.

Figure 1. Downtown South.

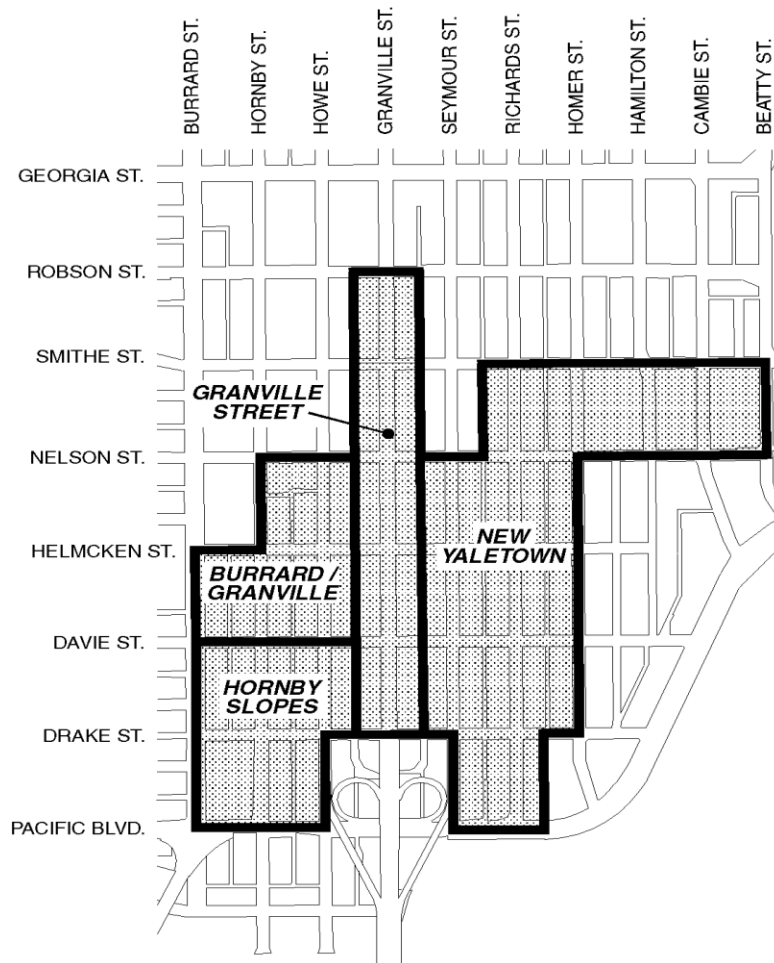

Note: See **Granville Street (Downtown South) Guidelines** for guidelines which apply to the 800 - 1200 blocks of Granville Street.

2 General Design Considerations

2.1/2.2 Neighbourhood and Streetscape Character

The guidelines in this document focus on two key factors in generating character for the New Yaletown, Hornby Slopes and Burrard/Granville areas of Downtown South - the creation of a neighbourhood identity and the achievement of livability. This area is developing incrementally from a low density mixed development area into a high density residential neighbourhood. While there are some notable heritage buildings in the area, the majority of the existing older buildings do not provide a strong basis for neighbourhood character. The character must be created rather than borrowed.

Distinct neighbourhood character can be generated by creating a special focus and by using consistent development patterns. The special focus for the area is park land, combined with the important shopping streets of Davie and Granville which cross the community.

In Downtown South, a consistent pattern is the strong street edge definition. An animated and inter-active street edge definition is critical to making Downtown South a lively residential community. The objective is to create safe, active, attractive streets with visual interest for pedestrians and motorists.

Consistency is also provided by the general development form of low-rise street-oriented development punctuated by a maximum of four widely spaced towers per full block, with a secured "inner sanctum" of green spaces at grade and on low-rise building roofs.

Another important pattern is a heavily "greened" streetscape. In New Yaletown, a double row of trees within an expanded public realm ensures that the streets become attractive "living rooms" while retaining their traffic function. In the Hornby Slopes and Burrard/Granville areas, greenery is provided through a landscaped building edge and a single row of trees. The overall "green" streetscape concept will be enlivened by seating areas and well chosen gathering places.

Within this strong pattern will be a variety of building forms resulting from retention of some existing buildings and construction of lower-density, mid-rise buildings where site sizes do not accommodate the highest densities, or where City-adopted view corridors limit heights. Most importantly, the varied architectural expression which is a hallmark of Vancouver will prevail.

Another major factor, livability, is ensured in a number of ways. The restriction on the number of towers per block and attention to their spacing provides a feeling of light and air. Middle and distant views outward from units also contribute to the perception of spaciousness. Private and semi-private open space, car and service access, acoustics, privacy, and security are also important livability features, and are addressed in these guidelines. The greening of streets and private landscaped areas as oases to walk through and to look down on is crucial to the feeling of neighbourhood livability. In designing these spaces attention needs to be given to informal surveillance, safety, "eyes on the streets" and territoriality. Finally, a public realm along street edges which does not compromise the comfort and security of the resident, but which is hospitable to neighbours and passersby, will provide cohesive links for the neighbourhood.

Commercial activity for the area will be concentrated on Davie and Granville Streets.

The vision for Granville Street, set out in the **Granville Street Guidelines**, is to create a strong retail pedestrian core for the community and a vibrant entertainment district for the region, building on the street's existing heritage character.

Figure 2. Example of Treed Public Realm similar to that sought in Downtown South.



Figure 3. Building Forms: Low-rise Street Wall and Tower.



2.3 Orientation

The orthogonal alignment of principal building faces to the street grid is an important ordering principle.

2.4 Views

2.4.1 Public Views

Council-approved public view cones pass through Downtown South and limit height on some development sites as noted in the Official Development Plan.

On sites affected by approved view cones, variation from the setback guidelines may be considered subject to livability standards, with the exception of the 12 foot front yard setback in New Yaletown, and the 6 foot front yard setback in Hornby Slopes and Burrard-Granville, which are dedicated to the public realm.

2.4.2 Private Views

Vancouver's spectacular views are an asset that should be shared between a proposed project and existing and future developments on surrounding sites. For this reason, development, in accommodating the functional necessities of the uses being provided, should be massed as compactly as possible, both in height and width.

- (a) The massing of any project should be configured and situated so that significant distant views can be shared between a proposed project and existing and future developments on surrounding sites. This can be achieved with slim, compact towers that maximize views between buildings rather than wide towers that block views, and the appropriate height, siting and spacing of towers in relation to other existing and future projects. For example, the proposed tower could be offset from existing and/or future towers. It is important to anticipate the most likely position of future towers on nearby development sites.
- (b) New developments should be designed and landscaped to provide for attractive near views for existing adjacent development as well as for the new units.

2.6 Light and Ventilation

Natural light, sunlight and ventilation are essential to residential livability and the success of public or semi-private open space. In Downtown South, building setback and horizontal angle of daylight guidelines (Refer to Section 4) provide a minimum separation between residential buildings in order to preserve light and ventilation for residential units. The massing of developments should, therefore, be as compact as possible to minimize height, and consequently, shadow impact.

Sunlight access for parks, open spaces, Davie Street, and Granville Street is a priority in Downtown South. Developments should be designed to prevent overshadowing on parks and public open spaces, to minimize overshadowing on Davie and Granville Streets and, if possible, on semi-private open spaces.

2.6.1 General Shadow Criteria

- (a) Shadows generated by proposed developments must be minimized on the following prioritized hierarchy of spaces:
 - parks
 - public open spaces
 - Davie Street and Granville Street
 - semi-private and private open spaces
- (b) New developments should be designed to preclude shadowing across the property line of parks and public open spaces. Development Applications should illustrate how tower massing has been minimized to reduce tower impact.
- (c) Developments over 35 feet in height require a shadow impact analysis taken at the equinox, at 10:00 a.m., noon, 2:00 p.m., and 4:00 p.m. Pacific Standard Time. Additional information may be needed on specific sites where shadow impact is a concern.

2.6.2 Shadow Criteria Specific to Granville and Davie Streets

- (a) The low and mid-rise portions of new developments along the south side of Davie Street should not cast shadows beyond the curb line of the north side of Davie Street. Tower portions of new developments on Davie and Seymour Streets should be massed (siting, height, width) so as to minimize the shadow impact on the north Davie Street and west Granville Street sidewalks, particularly during the noon to 2:00 p.m. period.

2.6.3 Tower shadow criteria

- (a) Towers of new developments should generate no more than 2 hours of shadow on semi-private open spaces on neighbouring developments between the hours of 10:00 a.m. and 4:00 p.m. at the equinox.

2.6.4 Light Access

Light access can be a problem when residential units are located below-grade resulting in reduced livability.

- (a) Below-grade residential units are generally discouraged.
- (b) Where new development abuts or is adjacent to existing hotels or rooming houses, it is essential to maintain adequate light and ventilation for the existing building. (Refer to **Guidelines for New Development Adjacent to Hotels and Rooming Houses**).

2.7 Weather Protection

- (a) New developments along Davie Street, where retail is required, should provide for continuous weather protection in the form of awnings or canopies (Refer to Section 5.6 for awning and canopy guidelines).
- (b) Buildings should generally be designed to mitigate wind impact at grade.

2.8 Noise

Most development sites in Downtown South are severely affected by noise, especially from heavy vehicular traffic or from uses which generate a lot of noise, such as cabarets.

- (a) Appropriate design and construction techniques which can be used to buffer residential units from noise, include:
 - orienting outdoor areas and bedrooms away from noise sources;
 - using alternate ventilation (to provide an alternative to opening windows);
 - using concrete construction;
 - using glass block walls, or acoustically rated glazing; and
 - using sound absorptive materials and sound barriers on balconies.
- (b) A development permit application for dwelling uses in Downtown South should provide evidence in the form of a report and recommendations prepared by persons trained in acoustics and current techniques of noise measurements demonstrating that the noise levels in those portions of the dwelling units listed below shall not exceed the noise levels expressed in decibels set opposite such portions of the dwelling units. For the purposes of this section the noise level is the A-weighted 24-hour equivalent (Leq) sound level and will be defined simply as the noise level in decibels.

Portion of Dwelling Unit	Noise Level (Decibels)
bedrooms	35
living, dining, recreation rooms	40
kitchen, bathrooms, hallways	45

2.9 Privacy

Privacy is a crucial aspect of livability. Minimum distances between buildings through required setbacks provide some visual privacy.

- (a) Unit orientation and screening should be used to enhance privacy.
- (b) Residential units located at street level should ensure privacy through setbacks, level changes or occupancies such as live/work units.

2.10 Safety and Security

Designs should be safe and secure yet not fortress-like. Issues to consider are: auto and bicycle theft in the underground; break and enter; and mischief such as graffiti and loitering in alcoves. Special attention should be paid to places with minimal natural surveillance or guardianship such as parking garages.

2.10.1 Open Space

- (a) Residential design should clearly delineate public, private and semi-private spaces and minimize semi-public spaces that have no clear purpose or use and may consequently become “no man's land”.

2.10.2 Underground Parking

Visitor parking should be separate from residents parking and secured with an overhead gate and electronic communication to residential units. If elevator access is provided at the visitor parking level, it should be electronically secured. The separation should be stronger than chain link, such as steel or aluminum fencing, and should allow for visual surveillance.

Public and commercial parking should be fully separate from resident parking and consideration should be given to securing these areas during non-operating hours.

Walls and ceilings of underground parking areas should be painted white to improve visibility.

2.10.3 Exits

Doors from elevator lobbies should be locked with key or card access in the direction from the lobby to residents parking areas (opposite to the direction of fire exit).

Open exit stairs from underground parking can be a security problem. This can be mitigated by locating exit stairs within the building envelope, with only an exit door exposed. An open exit stair can also be located in the semi-private open space where it can be watched by residents. Consideration should be given to provision of a full length, steel astragal on the exterior of the door without a door knob.

Exit stairs from the underground parking into lobbies have provided break and enter opportunities. Where these doors cannot be locked due to fire exiting, it is preferred that they exit to the outdoors rather than into the lobby.

Exit door alcoves are generally discouraged.

2.10.4 Lower Level Units

Ground level and podium level residential units and associated semi-private and private open space should be designed to reduce areas of concealment outside of the units, and to ensure good surveillance by other units in the development. Consideration should also be given to providing electronic security to these units. Where residential units face semi-private open space, this space should be secured by an unclimbable fence at the lane.

2.10.5 Exterior Surfaces

Graffiti is prevalent in the Downtown and its removal is an expense to many building owners and strata councils. Graffiti generally occurs on blank, exposed surfaces such as walls on lanes. Opportunities for graffiti can be mitigated by reducing areas of blank wall, by covering these walls with vines, lattice or steel mesh or by using a coating material.

Reduce opportunities for skateboarding where this is not a sanctioned activity. This can be achieved with rough paving material and planter walls with reveals.

2.11 Access and Circulation

2.11.1 Pedestrian Access

- (a) Primary pedestrian access should be from the street. (Refer to Section 5.3 regarding entrance guidelines.)

2.11.2 Vehicular Access

A welcoming pedestrian environment with continuous street edge definitions, display gardens, and street trees is critical to the emerging character of Downtown South. To this end it is important that vehicular and service functions remain primarily on the lane, so as not to conflict with pedestrian-oriented street activity.

Lane Access

- (a) All vehicular access to underground parking and on-site passenger facilities, loading and service areas should be from the lane for both residential and commercial uses and servicing.
- (b) Negative impacts of parking ramps and entrances should be minimized through treatment such as enclosure, screening, high quality finishes, sensitive lighting, and landscaping.

Figure 4. Lane Access Options.

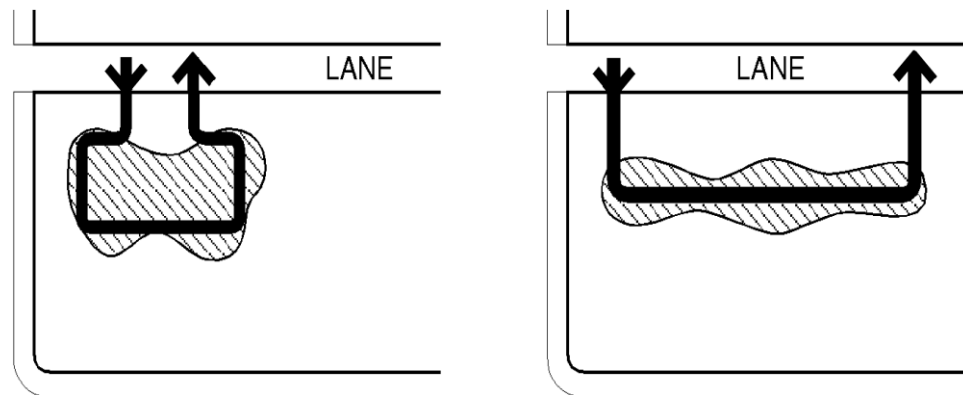

Street Access

- (a) In general, all vehicular access should be from the lane. In extraordinary circumstances where there is no lane, access may be provided from the street.
- (b) In exceptional cases for sites sharing a lane with Granville Street, where the lane environment is noticeably more unattractive and unlikely to redevelop on the Granville Street side due to Heritage retention objectives, some flexibility for a single street access may be considered.

Both (a) and (b) above are subject to:

- (i) access provided on north-south block faces only, not east/west streets whose short block faces are already interrupted by lanes;
- (ii) minimal interruption of the pedestrian realm and streetscape treatment;
- (iii) locating any waiting, or pick-up drop-off areas internal to the site, not in the public right-of-way or in the required setback;
- (iv) no more than one street access interruption per block face;
- (v) only one curb cut on the street; and

- (vi) further qualitative treatment discussed under Lane Access (b) above, and (c), (d) below. Refer also to sections 4.3.1. and 5.5.3.
- (c) Any vehicular entrance and its associated components (doorways, ramps, etc.), whether from the street or lane, should be architecturally integrated into the building so as to minimize its exposure. In particular, ramps located directly off the street or lane should be avoided.
- (d) Continuation of the Downtown South streetscape and public realm is important in the design of vehicular access from the street. A high standard of landscaping, architectural materials, and detailing should be provided. Integration of landscaped open spaces to balance the hard surfaces of vehicular access should be provided.

Figure 5. Street Access.

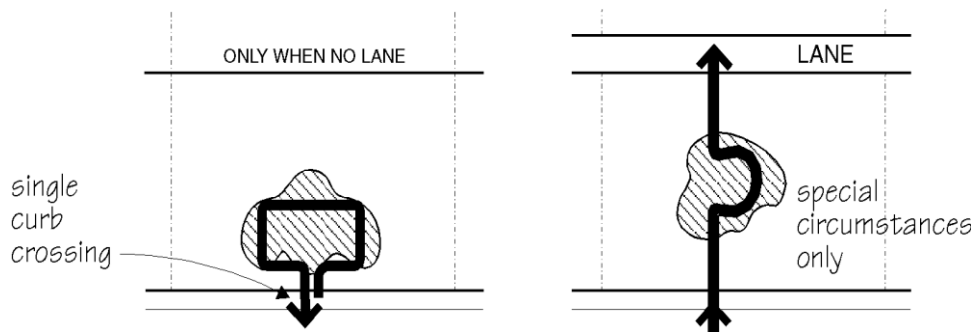

On-site Passenger Facilities

On-site passenger facilities, or “Porte cocheres”, are a marketing advantage and a convenience for visitors to a building. When accessed from the lane, they can add an attractive, functional, active element that contributes significantly to the upgrading of the lane's physical and safety environment. This is particularly the case when combined with visually accessible lobbies that create a gracious point of arrival to users and visitors of the development. When combined with landscaped open space, they may also provide opportunities for visual links from the street through courtyards and/or glazed lobbies to on-site landscaped areas.

- (a) The overall design and architectural landscape treatment of all on-site passenger facilities should enhance the lane environment;
- (b) The extent and nature of landscape cover may vary, depending on usage, but considerations of vehicular noise control, creating a pleasantly lit space, and overview from above are important considerations; and
- (c) Where possible, a landscape buffer should be provided between the lane and any on-site passenger facilities to provide visual relief to the hard surfaces while keeping it visually open to the lane.

Figure 6. Lane Drop-Off Porte Cochere.



2.12 Heritage

Downtown South contains a number of buildings on the **City's Vancouver Heritage Registry**. When developing a site which contains a heritage building, retention options should be explored. Similarly, adjacent sites, when undergoing redevelopment, should respect heritage buildings.

Other character buildings and artifacts such as prominent neon signs and stone fences, although not listed on the Registry, should also be considered for retention and/or integration into new developments.

3 Uses

The low-rise portion of a development, which is intended to create street enclosure and “eyes on the street”, could contain residential, office and/or related uses as permitted in the Downtown Official Development Plan. A combination of permitted uses within self-contained units may be accommodated in the low-rise street wall component of the project, provided such units have direct access to the street. Self-contained units that have direct access from the street are permitted to change uses within the units provided the new occupancy is in compliance with all relevant municipal regulations.

4 Height, Setback, Parking and Horizontal Angle of Daylight Guidelines

These guidelines should be considered as standard treatment in Downtown South. Exceptions to the standard are noted where applicable.

4.1 Height and Massing

Downtown South is characterized by a variety of building heights, including low, medium and high-rise developments.

4.1.1 Low Rise Street Enclosure

- (a) New developments should provide for continuous street edge definition through:
 - (i) low-rise street enclosure buildings, a minimum of 30 feet in height, with active uses along the street frontage. This is particularly desirable at corners, and along short block ends. Low-rise buildings on the street edge should also appropriately respond to adjacent street wall development, particularly on Homer Street across from historic Yaletown and along Davie Street where continuous retail activity is required.
 - (ii) open space defined by walls, fences, pergolas, colonnades and other appropriate landscape elements. Such definition through open spaces is appropriate in mid-block locations. The defining elements should not be located within the required setback. Refer to Section 7.2 for design of open spaces.

**Figures 7 and 8.
Low Rise Street Wall
defining the Public
Realm at a pedestrian
scale and providing
“eyes on the street”.**



4.1.2 Tower Height

The maximum discretionary height in Downtown South is 300 feet. This maximum height typically provides considerable latitude in tower massing to accommodate permitted floor area within smaller or larger floor plates, as desired by the developer, while responding to specific site conditions, the need to minimize tower bulk and, where applicable, respect Council approved view corridors.

Tower height will be evaluated against the following hierarchy of public objectives, listed in order of importance:

- (i) shadow impacts on public spaces and shopping streets (Granville and Davie Streets), (see Section 2.6 for shadowing criteria);
- (ii) impact on private views, such as view blockage from/to adjacent existing and/or future developments; and
- (iii) shadow impact on semi-private and private open spaces, in particular landscaped open spaces in adjacent residential developments.

4.1.3 Tower Width and Floor Plate Size

Compact slim towers with small floor plates minimize shadowing, maximize separation and views between buildings, and reduce privacy and overlook impacts. To achieve the objective of compact slimmer towers, yet allow for tower massing flexibility, floor plates above 70 feet will be guided by the following principles:

- (a) The maximum horizontal tower width or depth dimension is 90 feet. Generally, optimum tower widths to the fronting streets -- typically north-south streets -- should be in the range of 75 - 85 ft.

Maximum widths are measured to the outermost dimension of the typical tower floor. Open balconies may project beyond the maximum widths provided such projections do not exceed more than 1/3 of the overall length of the facade. Articulation of the tower in both plan and profile to break up its mass and convey a residential character, as well as terraced, stepped floors at upper levels, should be incorporated to diminish overall scale and minimize shadowing and view blockage. Where the maximum tower width is utilized, sculpting of the uppermost 1/3 of the tower becomes even more important. Residential features such as bay windows, open balconies, staggered planes and projections to provide corner windows, terraced massing for roof decks at different levels, varied fenestration patterns, etc., should be incorporated.

- (b) The maximum floor plate of any tower will be limited to 6,500 square feet gross (including elevator cores, storage, stairs, enclosed balconies, etc. but excluding open balconies).

For sites with frontages up to and including 300 feet, the maximum floor plate size is further guided by the parameters outlined in Table 1, which are based on the premise that as height increases on a given site, tower width/floor plate should decrease. For sites with frontages greater than 300 feet, some latitude in floor plate size may be considered in order to accommodate the greater permitted floor area available on larger sites. Tower articulation in both plan and profile, as described in (a) above should be incorporated.

The floor plate sizes outlined in Table 1 convey a general framework and may be increased where it can be demonstrated that doing so would result in a superior response to massing objectives described earlier. This could also apply in instances where heritage density bonuses or view corridors are to be accommodated.

Table 1: Guide to Maximum Typical Floor Plate Size

Note: The front and rear setbacks in Downtown South generally result in a tower depth dimension of 75 - 80 feet on typical sites.

	SITE FRONTAGE (ASSUMED DEPTH 120 FT.)					
Tower Height +	175 ft.	200 ft.	225 ft.	250 ft.	275 ft.	300 ft.
300 ft.	3,500 ft ²	4,000 ft ²	4,500 ft ²	5,000 ft ²	5,500 ft ²	6,000 ft ²
250 ft.	4,000 ft ²	4,500 ft ²	5,000 ft ²	5,500 ft ²	6,000 ft ²	6,500 ft ² *
200 ft.	5,000 ft ²	5,700 ft ²	6,500 ft ² *	6,500 ft ² *	6,500 ft ² *	6,500 ft ² *

+ generally, for intermediate heights, floor plate sizes should be interpolated

* maximum floor plate size of 6,500 sq. ft. applies

- (c) Minor projections which add to tower articulation such as bay windows may be considered into the front setback above 80 feet in height provided such projections are not more than 3 feet in depth and do not exceed more than 1/3 of the overall length of the facade.
- (d) Portions of the tower below 70 feet may expand beyond these limitations provided this can be done without negatively affecting adjacent development.
- (e) There are no maximum floorplates for office towers in the Hornby Slopes and Burrard/Granville areas.
- (f) Floor plates of hotel towers in the Burrard-Granville areas should generally follow the guidelines set out for towers above 70 feet in the residential areas.

Refer to Table 1. Subject to responding to view corridors and shadowing criteria (refer to Sections 2.4 and 2.6), most sites will accommodate a variety of tower massing options containing the same amount of floor area (i.e., higher and slimmer, or lower and wider).

Figure 9 and 10. Tower Massing Flexibility

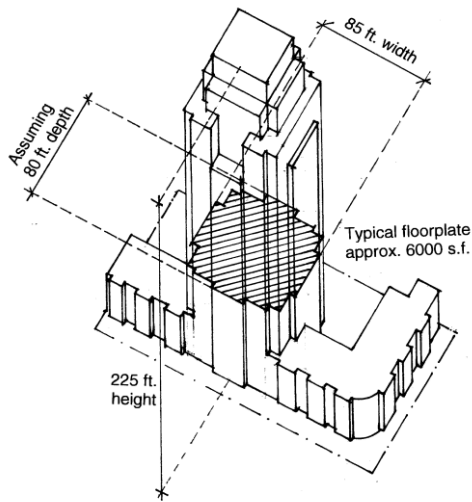

Lower, wider tower configuration larger floorplate.

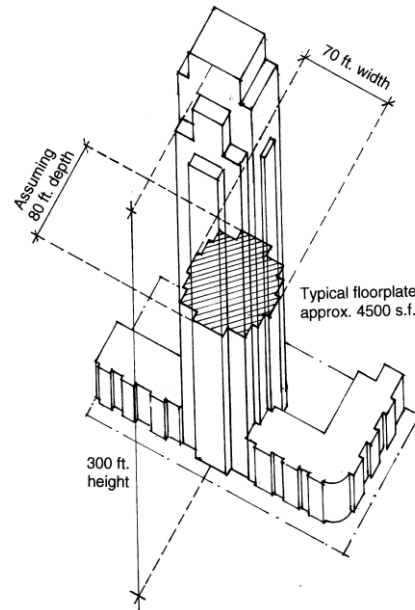

Higher, slimmer tower configuration with configuration with smaller floor plate.

Figure 11. Lower, Wider Tower.



Figure 12. Higher, Slimmer Tower.



4.1.4 Floor-to-Floor Height

Generally, the development industry's standard residential floor-to-floor dimension is 8'6" to 9'0" yielding ceiling heights of 8'0" to 8'6". This dimension provides a standard of livability within dwelling units that has long been accepted by urban and suburban dwellers. In some instances, higher ceiling heights are desired to accommodate different markets and, to a degree, this can be accommodated subject to the limits imposed by view corridors, shadow criteria, floor plate size and other guideline parameters. Therefore, within the maximum heights permitted in the Downtown Official Development Plan and subject to the limits imposed by view corridors and other criteria in these guidelines, floor-to-floor heights may be adjusted through the following 10 ft. floor-to-floor averaging formula:

- a) irrespective of the actual floor-to-floor heights proposed, the overall building height should be limited by a calculation of 10'0" multiplied by the number of floors proposed in the development.

Note: for the purposes of this calculation, lofts or mezzanines are not counted as floors when they generate open-to-below area greater than 10% of the area of the lower level within any unit. Any open-to-below area beyond that accommodated in this averaging formula will be counted as floor area in the Floor Space Ratio calculation for the development.

- b) on those sites where tower massing and height are particularly sensitive (i.e., where shadowing of public open space, or Granville or Davie Streets may occur), a standard floor-to-floor height should be used.

4.2 Setbacks

4.2.1 Front Yard and Setbacks

The front setback is the most public aspect of the site. Its treatment strongly influences streetscape character (Refer to Section 2.2). The treatment of the required front yard setback should reflect the Downtown South streetscape design concept (Refer to Section 8).

- (a) Front setbacks for buildings in New Yaletown should be as follows:

Height	Minimum	Maximum
0 - 70 ft.	12 ft.	20 ft.
Over 70 ft.	12 ft.	no maximum

- (b) Front setbacks for buildings in Hornby Slopes and Burrard-Granville should be as follows:

Height	Minimum	Maximum
0 - 70 ft.	6 ft.	20 ft.
Over 70 ft.	6 ft.	no maximum

- (c) Exceptions may be considered:
 - (i) to the minimum setback only to allow transition to existing permanent or heritage buildings; and
 - (ii) to the maximum setback occasionally to allow entries, or pocket parks where they meet public objectives.

Figure 13. Front Setback with second row of trees and display gardens.



4.2.2 Side Yards and Setbacks

Exterior side setbacks on corner sites should be consistent with front setbacks in order to ensure streetscape continuity, and should follow streetscape treatment guidelines.

- (a) Exterior side yard setbacks for buildings in New Yaletown should be as follows:

Height	Minimum	Maximum
0 - 70 ft.	12 ft.	20 ft.
Over 70 ft.	12 ft.	no maximum

- (b) Exterior setbacks for buildings in Hornby Slopes and Burrard-Granville should be as follows:

Height	Minimum	Maximum
0 - 70 ft.	6 ft.	20 ft.
Over 70 ft.	6 ft.	no maximum

- (c) Exceptions are Pacific Boulevard and Davie Street where a minimum 10 ft. setback should be provided.

- (d) Interior side yard setbacks for buildings in New Yaletown, Hornby Slopes and Burrard-Granville should be as follows:

Height	Minimum	Maximum
0 - 70 ft.	none	none
Over 70 ft.	40 ft.	no maximum

- (e) While no specific interior side yards are required up to 70 feet in height, building massing is expected to maintain a neighbourly relationship to adjacent development sites, taking into account both the existing and potential future conditions when redevelopment of adjacent sites occurs.

4.2.3 Rear Yard and Setbacks

- (a) Rear yard setbacks for buildings in New Yaletown, Hornby Slopes and Burrard-Granville should be as follows:

Height	Minimum	Maximum
0 - 35 ft.	10 ft.	no maximum
Over 35 ft.	30 ft.	no maximum

- (b) The purpose of the rear yard setback area is to provide space for the required planting of trees and landscaping. Trellising, screen walls, pergolas and other such landscaping elements may protrude into the rear yard where these contribute to a positive, safe lane environment.

- (c) On a corner site, to ensure street definition and continuation of the streetscape, a building element of a minimum height of 30 feet and a maximum height of 70 feet should be extended along the flanking street to the rear property line. Further, this element should extend down the lane for a minimum distance of 40 feet and a maximum distance of 110 feet. (Refer to Figures 16 and 17);

- (d) The extension of the building element to the rear property line on corner sites creates a "portal" to the landscaped edges of the lane. High quality street facade treatment and materials should be extended around to the lane facade and continued along the length of the lane-abutting building element to enhance the lane environment;

- (e) In low-rise portions of developments where double-fronting residential units (ie. townhouses) have entrances facing both an internal courtyard and a lane, entrance stairs, walkways and raised planters may be located within the setback, provided that issues of privacy, security, light access, and overlook for residential units facing the lane are addressed.

- (f) Roofs of buildings abutting the rear yard setback should be landscaped and the lane edge should be formed by articulated walls, utilizing high quality materials and treated with landscaping to enhance the lane environment and outlook for developments to the rear.

Figure 14. Setbacks: Mid-block sites — New Yaletown.

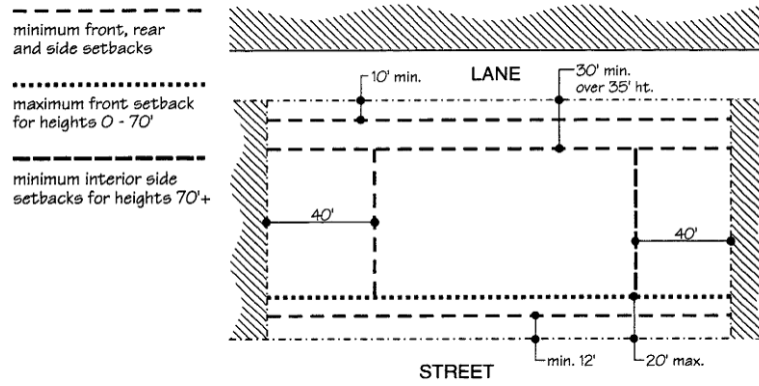

Figure 15. Setbacks: Mid-block — Hornby Slope and Burrard-Granville.

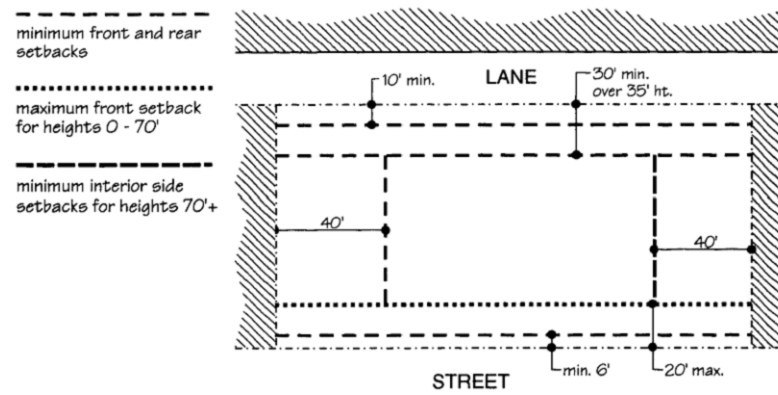

Figure 16. Setbacks: Corner Sites — New Yaletown.

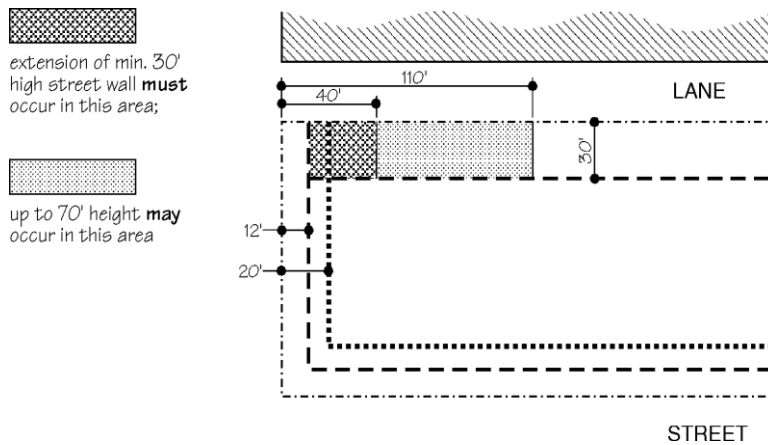
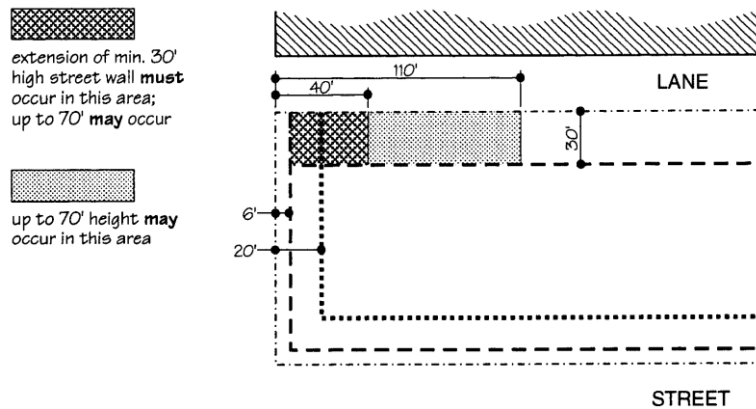

Figure 17. Setbacks: Corner Sites — Hornby Slopes and Burrard-Granville.



4.2.4 Two Towers Per Site

The minimum frontage for any development consisting of two or more towers exceeding 70 feet in height is 375 feet and the minimum site area is 45,000 square feet. The portions of the towers which exceed 70 feet should be at least 80 feet apart.

4.3 Floor Space Ratio

Small development sites (those not meeting the minimum frontage and site size requirements qualifying development for consideration of densities of up to 5.0 FSR as provided for in the Downtown District Official Development Plan) shall not be considered for floor space bonusing beyond the 10 per cent increase in floor space which can be considered for heritage density transfers and the density provisions for affordable housing projects, unless both these exceptional circumstances are met:

- There will be no opportunity for more than two towers on a block face, due to the frontage restrictions in the DDODP and the pattern of development sites; and
- Higher elements (i.e. those portions of a building over 70 feet (21.4 m) in height) of the building are a minimum of 80 feet (24.4 m) away from an adjacent tower.

4.4 Off-Street Parking and Loading

Vehicular access locations and on-site passenger facilities are discussed in Section 2.11.

4.4.1 Parking

Parking structures have the potential to create blank walls on the public street and lanes, to present open parking to the lane, to unnecessarily increase the bulk of the building (because parking levels "at" grade are not counted in floor space ratio), and to compromise other uses of the site surface. Therefore:

- Parking should be underground.
- Parking entrances should be architecturally treated and should incorporate landscaping to mitigate the appearance of blank walls and dark openings with long ramps.

Figure 18.
Parking Entrances.

Not this:
Blank, poorly
treated walls,
straight access



Figure 19.
Parking Entrances.

This:
Landscaping and
High quality
materials



4.4.2 Loading

Required headroom for loading can create spaces which present a dark concrete cavern with a ceiling of messy mechanical systems and glaring fluorescent lights to residents across the lane. Therefore:

- (a) Loading spaces, if necessary, may be located at grade open to the lane, but should be solidly roofed to avoid noise and visual impacts on those above. Negative impacts are to be avoided through appropriate height, lighting, painting, and screening (including possibly doors). Loading spaces should be securable at night for safety reasons.
- (b) In high-density projects (floor space ratio greater than 3.0), garbage facilities and recycling facilities should be provided underground or fully within the building, with provision made for moving bins to (or opening doors to) the lane only for pick-up. In smaller projects, where such arrangements may not be feasible, garbage and recycling facilities may be located adjacent to the lane, but should be fully enclosed on roof and sides, with gating to the lane.

4.5 Horizontal Angle of Daylight

- (a) All habitable rooms in buildings containing 3 or more dwelling units should have at least 1 window on an exterior wall which complies with the following:
 - (i) the window shall be located so that a plane or planes extending from the window and formed by an angle of 50 degrees, or 2 angles with a sum of 70 degrees, shall be unobstructed over a distance of 80 feet; and
 - (ii) the plane or planes shall be measured horizontally from the centre of the bottom of the window.

- (b) For projects with a floor space ratio of 3.0 or less, consideration may be given to relaxation of the horizontal angle of daylight requirement provided that a minimum distance of 20 feet of unobstructed view is maintained.
- (c) For the purpose of calculation of the horizontal angle of daylight, the following are considered as obstructions:
 - (i) the largest building permitted under the zoning on any adjoining sites; and
 - (ii) part of the same building including permitted projections.
- (d) For the purpose of Section 4.4(a), the following should not be considered as habitable rooms:
 - (i) bathrooms; and
 - (ii) kitchens, unless the floor area is greater than 10 percent of the total floor area of the dwelling unit, or 100 square feet, whichever is the greater.

5 Architectural Components

In general the intent is for Downtown South projects to continue the tradition of creative architectural “expressionism” which characterizes Vancouver’s Downtown and West End. Therefore, rather than specifying particular style directions, materials, palettes, etc., the following guidelines deal with how the architectural aspects of the buildings should perform.

For the sake of simplicity, in this and following sections the “front” of a site is deemed to be the edge abutting the north/south streets (e.g. Howe, Hornby, Richards, etc.) even if the site dimension on that side is less than the dimension on the flanking street.

5.1 Roofs

- (a) Towers should contribute to the skyline, either through the incorporation of sculpted roof “caps”, terracing, or otherwise sculpting of the upper floors of the building.
- (b) Section 10.18 of the Zoning Bylaw describes height relaxation provisions that apply for tower roofs. These relaxations will not be considered, however, for buildings in Council-adopted view cones.
- (c) Low and mid-rise building roofs should utilize a variety of roof treatments and be designed to be attractive as seen from above.
- (d) Vents, mechanical rooms and equipment, elevator penthouses, etc., should be integrated into the roof architectural treatment or should be screened with materials and finishes compatible with the building.

Figure 20 and 21. Sculpted Tower Roofs.



5.3 Entrances

Entrances animate the streets and create identity and a sense of address for buildings, dwelling units and stores.

Residential and Commercial Uses

- (a) Residential and commercial use entries to buildings should be separate and identifiable. Where residential use is located on the first floor, individual unit entries should be located on the street to emphasize the residential nature of the area.

Figure 22.
Residential Unit Entrance
facing the street.



- (b) Entrances should be enhanced through the use of elements such as low walls, steps, special paving, special planting features, architecturally integrated canopies projecting from the building (which may project into the required setback), and special lighting.
- (c) Entrances should be seen as “punctuation” in the overall streetscape treatment of a double row of trees and display gardens. Removal of trees for entries, and extensive displacement or narrowing of display garden area with steps, ramps etc. is to be avoided.

Figures 23 and 24.
Residential Tower
Entrances.



- (d) A small sized, paved “courtyard” area at an entry to a tower is appropriate, particularly on a corner, but extensive paved areas which detract from the overall green streetscape concept are not appropriate.

**Figure 25.
Courtyard Area
Entrance.**



Retail Uses

- (e) Individualized entries to retail, restaurant and service establishments should be provided immediately off the street.

**Figure 25.
Courtyard Area
Entrance.**



5.4 Balconies

- (a) Balconies should be designed as an integrated part of the building. (Refer to Section 7.3 Private Open Space.)
- (b) Some balconies may be enclosed (e.g. for acoustic purposes) to the extent specified in the Downtown Official Development Plan, subject to Council-adopted Balcony Enclosure Guidelines.

- (c) In certain limited circumstances, such as constantly shadowed locations or as a second balcony within a unit, provision of a narrow (up to 2 ft.), open “step-out” or French balcony may be appropriate. French balcony guardrails should be predominantly open rail or glass to maximize natural light penetration.

5.5 Exterior Walls and Finishing

5.5.1 Lower Floors of Buildings

The lower floors of buildings form part of the streetscape, and are important in shaping the public realm and pedestrian character of streets. The street definition formed by tower and low-rise could contain residential, commercial, live/work, cultural or retail uses (Refer to Section 4), and is intended to play an important role in making the high density development and busy streets more human and intimate in both scale and activity.

- (a) Devices such as a change in material, cornice lines, and change in fenestration scale should be used to achieve a comfortable pedestrian scale at lower levels.
- (b) Richer materials, more intensive decorative details and lighting should be used to enhance the “close up” view for the pedestrian. In the case of retail uses, display windows, lighting, outdoor display and weather protection should be incorporated.
- (c) Commercial uses located on the lower floors should present a pedestrian scale and image in treatment and detailing, avoiding large expanses of glass, mirrored surfaces, etc.
- (d) Residential units located on the ground floor should locate the main floor level approximately 3'0" above grade to promote privacy for the units yet still maintain “eyes on the street” from the unit.

Figure 27.
Lower Floors of Buildings (Commercial) provide an active, pedestrian-oriented public realm where people can meet and develop a sense of neighbourhood.



Figures 28, 29 and 30.
Lower Floors of Buildings (Residential) with “eyes on the street”, trees, and display gardens provide a safe, attractive public realm.





5.5.2 Interior Sidewalls

The creation of large expanses of blank sidewall should be avoided. There may be cases where sidewalls are exposed to neighbouring properties, either on a temporary or permanent basis. This may occur where an existing building already has created a sidewall, where massing relaxations are given to protect view cones, or because different forms of development are abutting one another such as a single-loaded townhouse next to a double-loaded apartment or mid-rise buildings on smaller sites adjacent to two and three storey townhouses.

- (a) Where exposed sidewalls occur they should be designed to be attractive to neighbouring developments and passersby through the use of quality materials, colours, textures, modulation, articulation, and/or landscaping such as climbing and hanging plants.
- (b) In the case of the interior sidewalls of mid-rise buildings located on sites with frontages of 75 feet or more, setbacks, light wells and windows should be considered.

5.5.3 Lane Edges

Residents using underground parking experience the lane as an important entrance to their residential units. Therefore, lane treatment should be aesthetically pleasing and welcoming in addition to fulfilling functional requirements for vehicular and service access.

New developments are expected to significantly upgrade the appearance of the lane environment. Architectural treatment and landscaping of the lane facades should receive comparable detailing and attention as other facades of the project. On-site passenger facilities or “Porte cocheres” accessed from the lane should have associated lobbies, entrances and open landscaped areas to improve their visual quality and to add “eyes on the lane”. Corner sites in particular will have an opportunity to upgrade the portion of the lane which their users experience most often and to continue the sense of greenness from the streetscape into the lane. Architectural treatment and landscaping of rear setbacks and lane edges is therefore an important aspect of all developments.

**Figure 31.
Lane Treatment:
Carefully designed
Porte Cochere
creates a gracious
arrival point for
residents and
visitors.**



Figures 31 and 33. Land Edges Landscape Detail.



Surface parking is not permitted. Parking should be underground, enclosed and/or fully screened. The treatment of loading and garbage facilities is to be carefully considered (Refer to Section 4.3). Beyond this, the architecture and landscape design of the development should deal with the lane as an integral component of the project, with lane facades and landscape carefully considered to upgrade and enhance the lane environment.

- (a) Building walls abutting the lane should be attractive to neighbouring developments and passersby through articulation and use of quality materials and finishes. Blank walls facing the lane are discouraged.
- (b) Landscape materials should be incorporated in the projects adjacent to the lane through provision of climbing plants, hanging plants, and/or shrubs and trees of suitable growing habit (Refer to Section 8).

- (c) Soil depth for all landscaping should generally be a minimum of 3 feet 6 inches in depth and adequate centrally operated irrigation should be provided. Adequate space for healthy tree root development should be provided by trenches a minimum of 5 feet by 6 feet in size. Trenches and planters for trees should be contiguous with below grade soil volume in the lane.

5.5.4 Colour and Materials

- (a) A range of colours and materials is acceptable. However, because of Vancouver's often subdued or silvery quality of light as well as the high density and shadowing in the area, extensive use of dark colours is discouraged.
- (b) Where an existing permanent building is adjacent or nearby, the new development need not match, but should be designed to ensure visual compatibility.

5.5.5 Retail Frontages

- (a) Where retail is permitted, small, individual store frontages not exceeding 25 feet in width should be provided. Where a large tenancy is planned, it is desirable to locate the majority of its area behind smaller frontages, without creating an internalized "mall".
- (b) Display windows and individualized tenancy design should be used to enhance pedestrian interest.

5.6 Awnings, Canopies, Recesses and Arcades

- (a) Weather protection, while not required, is encouraged where appropriate on non-retail streets, but should be provided over entrances to residential and commercial uses. Weather protection is also encouraged in non-landscaped areas where the public might congregate.
Design and location of weather protection should be coordinated with the spacing for a double row of street trees and should allow for adequate sunlight and rainfall in landscaped areas. Supports for weather protection should be slender, attractive and located to minimize impacts on pedestrian traffic.
- (b) Continuous weather protection is required on Davie Street, in the form of awnings or canopies. These should be of sufficient depth to shelter outdoor display and seating, as well as to protect walking space on the city sidewalk. Weather protection on the order of 10 feet or more in depth is generally appropriate.
- (c) Generally, for major developments, canopies of permanent materials are preferred to vinyl or fabric ones. Design should reflect the building's architectural style and consideration should be given to integrating signage and lighting.
- (d) Arcades are generally discouraged, and may not be located within the required setback.

Figures 34 and 35. Awnings, Canopies.



5.7 Lighting

- (a) Lighting should be installed on the buildings and incorporated into the landscaped setbacks (in the form of wall sconces, garden lights, or set into edging features, etc.) to provide soft lower level illumination to the sidewalk areas as well as the building.
- (b) The use of free-standing pole lighting should be limited to entries and gathering places.
- (c) Incandescent or colour-corrected light sources should be used.

7 Open Space

7.1 Public Open Space

Public open space plays a vital role in the livability of high density residential areas and the successful integration of commercial and residential uses in Downtown South. Besides the parks and other public open spaces which will be provided, much of the sense of open space in Downtown South should come from the setbacks and streetscape.

7.2 Semi-Private Open Space

The provision of high quality, useable open space for common use by the residents of a development is an important element in making individual developments more livable in a high-density setting such as Downtown South. A range of activities should be considered when designing these spaces, from passive or visual amenities to active use areas. The design and use should directly relate to the intended residents of a project.

- (a) Residential developments should provide, exclusive of minimum setback areas, semi-private open space at grade or preferably on a roof having an aggregate size of fifty square feet per unit or more. It should be located to maximize sunlight penetration, minimize noise penetration and minimize “overlook” from adjacent units and neighbouring buildings. Residential units designed for families with children should have access to a secure outdoor space of appropriate size at grade or on a roof (Refer to **High Density Housing for Families with Children Guidelines**).
- (b) Open space should be designed to serve specific functions and activities for the development as well as provide visual amenity to the street. Clear views from the street into the landscaped open spaces are desirable. Opportunities for through-block open spaces in large developments are encouraged. Because the enclosing elements and landscaping will be

viewed by residents of neighbouring developments and pedestrians, consideration needs to be given to creating interest for both distant and close-up viewing. Detailing should be of the highest quality and should contribute to the general character of the streetscape. Attention should be paid to integrating the detailed design of the building(s), display gardens in the garden setback area, street defining elements and landscaping. (Refer to Section 8.1.4).

- (c) Any exterior swimming pools or playground areas should be located in screened locations internal to the development.
- (d) Downtown South streets have high traffic volumes. New developments should shield private and semi-private open spaces from excessive exhaust fumes, particularly at major intersections, through location or enclosure.

7.3 Private Open Space

Provision of private open space for each unit in the form of balconies, decks or patios is an important component of livability in a high density residential environment.

- (a) Residential units should have access to a private outdoor space with a minimum single horizontal dimension of 6 feet to allow for adequate useable space.
- (b) Where possible, private open spaces should be oriented to capture sunlight and take advantage of views.
- (c) Private open spaces should be designed to ensure visual privacy.
- (d) Private open spaces for residential units at grade should provide sufficient separation from the public realm either through grade separation or screening while not creating areas of concealment outside the units.

8 Landscaping

Landscape design is one of the most important elements of creating livable developments and neighbourhoods in Downtown South. The principle of “greening” Downtown South should be expressed in new development to provide visual relief from the intensity of the built form.

There are several different components of project landscaping: streetscape landscape treatment in setback areas, and private landscape treatment such as project open space, roofscapes and on-site passenger facilities (accessed from lanes).

8.1 Streetscape - All Areas Except Davie Street and Pacific Boulevard

8.1.1 Streetscape Character

The intent of the streetscape concept developed for Downtown South is to provide for a strongly public and pleasing streetscape. This is to be achieved through the integration of the public and private realm in which a double row of trees or a single row of trees, in specific areas, and display gardens will result in intense landscaping spanning both public and private property. A single row of trees will be provided in the Hornby Slopes and Burrard-Granville areas. In New Yaletown, a double row of trees will be provided. The double row of trees is intended to create a canopy over the sidewalk thus contributing to a pedestrian scale. Hard surfaces and street furniture are to be enhanced with decorative motifs using a botanical theme to reinforce the expression of natural forms in an urban environment. Complementing these key components is a distinctive, consistent blue-black colour for most metal surfaces.

The streetscape design uses “customized” stock items with specially designed motifs to create a distinctive Downtown South look. Major components such as street furnishings, decorative motifs, and sidewalk stamps, should be available through local suppliers. Details, specifications, and suppliers are further described in a manual available from the Streets Division of the Engineering Department.

Figure 36. Typical Streetscape View.

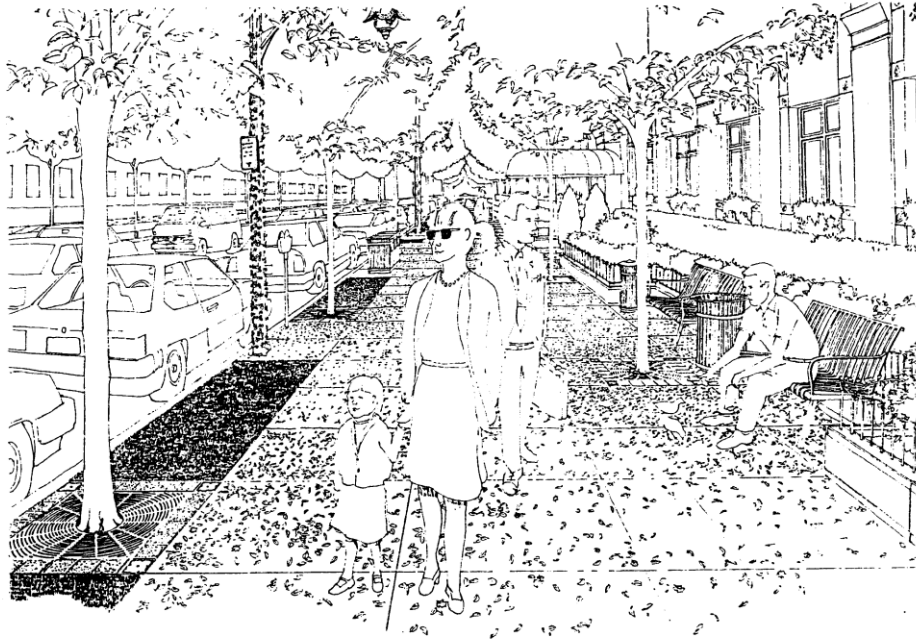

STREETSCAPE VIEW

CITY OF VANCOUVER
DOWNTOWN SOUTH

8.1.2 Setbacks

- (a) In New Yaletown, the minimum required 12 foot building setback should accommodate the second row of trees and the display gardens. The first 2 feet adjacent to the property line should permit a clear at-grade extension of the sidewalk, the next 4 feet permits the second row of trees and the remaining 6 feet allows for the display garden which may include some useable outdoor space. (Refer to figure 37).
- (b) In Hornby Slopes, the minimum 6 foot building setback should accommodate a 4 foot display garden which may include some useable outdoor space. The first 2 feet adjacent to the property line should permit a clear at-grade extension of the sidewalk. (Refer to figure 38).
- (c) Setbacks of up to 20 feet are permitted, which would offer more growing space for the trees, larger display garden areas, and further opportunities for appropriate public places within the privately-owned setback.

Figure 37.
Streetscape
Dimensions in
New Yaletown.

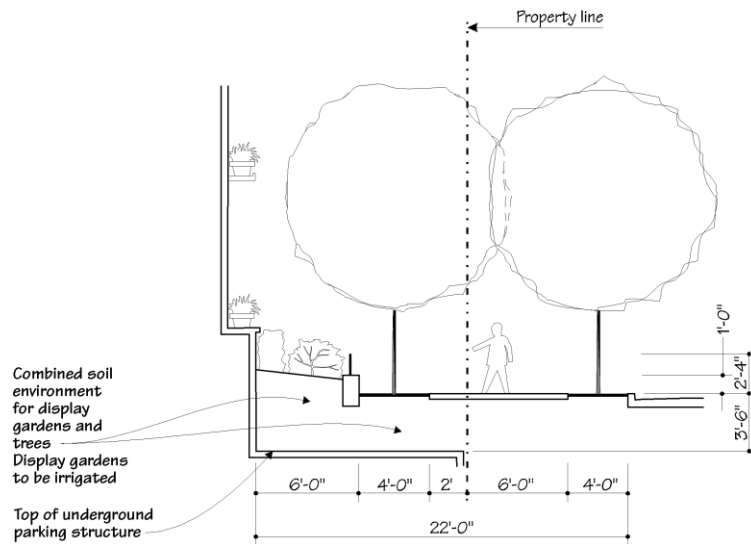
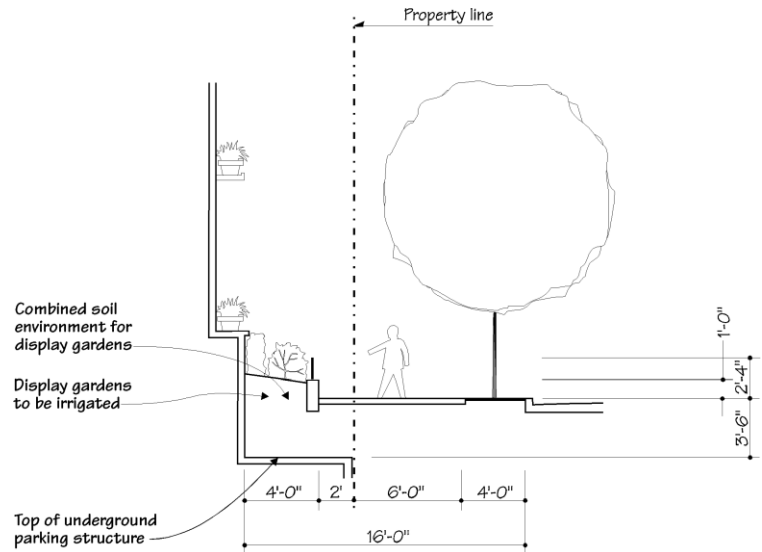

Figure 38.
Streetscape
Dimensions in
Hornby Slopes and
Burrard-Granville.



8.1.3 Trees

Species

A variety of tree species is encouraged throughout Downtown South to not only create more visual interest, but also to promote a healthier "urban forest" reducing the negative impact of tree pests and diseases. Nevertheless, some consistency can be maintained by specifying trees of similar scale and shape throughout Downtown South and, where possible, by continuity of the same variety within each block. Where a double row of trees is provided, the same variety of tree should be used in both rows.

The intent is to achieve a consistency of species on both sides of the street. Generally, the selection of species for both sides is set in consultation with the applicant for the first development on the block. Subsequent developments would normally be expected to plant the same variety wherever possible. The ultimate mature size of the selected trees should be as large as is practical and of a shape that maximizes the canopy effect while minimizing any possible negative impacts on adjacent buildings. Changes in species should be accommodated at block corners.

Applicants are advised to consult with the City Arborist for an updated list of recommended species, and to confirm the specific ultimate mature size and shape of the selected species. The final species selection and size for planting will be approved by the City Engineer in consultation with the Director of Planning.

Spacing

- (a) The second row of trees, located on private property, should be at approximately 25 foot intervals, staggered in relation to the curbside row of trees. The total number of trees should be maximized.
- (b) Building entrances and major window bays should be designed with tree spacing in mind.

Planting Requirements

It is likely that the row of trees on private property would be located over underground parking structures.

- (a) In New Yaletown, parking structures should be located far enough below the surface of the sidewalk in order to provide a minimum soil depth of 3'6" for healthy tree root development.
- (b) A below-grade soil environment conducive to tree root development should be provided by a continuous trough for the length of the display gardens. The trough should be at least 6 feet wide and ideally contiguous with the display garden soil volume. Adequate centrally-operated irrigation should be provided.

**Figure 39.
Double Row
Street Trees.**



8.1.4 Garden Setback Area

The remainder of the privately-owned setback portion of the streetscape is the garden setback area. This area should be dedicated to display gardens and useable outdoor spaces. It should be a minimum of 6 feet in New Yaletown, and a minimum of 4 feet in the Hornby Slopes and Burrard-Granville areas, (refer to figures 41 and 42). This garden setback area is intended as a visual amenity for the street and residents as well as a buffer between street activity and housing units. It may also be used by the residents of the adjacent residential units for their outdoor activities, but may not be screened off and made private.

- (a) Access from units to the setback area can be provided to encourage utilization and maintenance by residents, particularly in ground-oriented units.
- (b) The design of the setback area should encourage residents to plant flowers and to maintain the landscaping adjacent to their units as part of their outdoor activities. Outdoor water sources should be provided for each unit for any landscaping but should not be visible from the street for security reasons.
- (c) Useable outdoor spaces can be located within the minimum 6 feet garden setback adjacent to the building in New Yaletown, or within the 4 feet garden setback in the Hornby Slopes and Burrard-Granville areas. However, these useable outdoor spaces may not be screened off with planting, railings, fences, or raised walls.
- (d) A minimum of 60 percent of the garden setback area adjacent to the building should be soft landscaping, either oriented to useable outdoor space or providing garden display to the street. (Refer to figures 41 and 42).
- (e) A maximum of 40 percent of the garden setback area adjacent to the building may be in hard surface materials for active outdoor use, inclusive of entrance access walkways to ground oriented units. (Refer to figures 41 and 42.)
- (f) A sense of continuity of greenness and planting should be maintained between any hard surface portions of the setbacks and the sidewalk.
- (g) There should generally be a consistency of grade between the garden setback area and the sidewalk.
- (h) Ramps for disability access should be provided without extensive displacement of display garden areas.

Figure 40.
Garden Setback
Area with Display
Gardens.



**Figure 41.
Streetscape
Dimensions.**

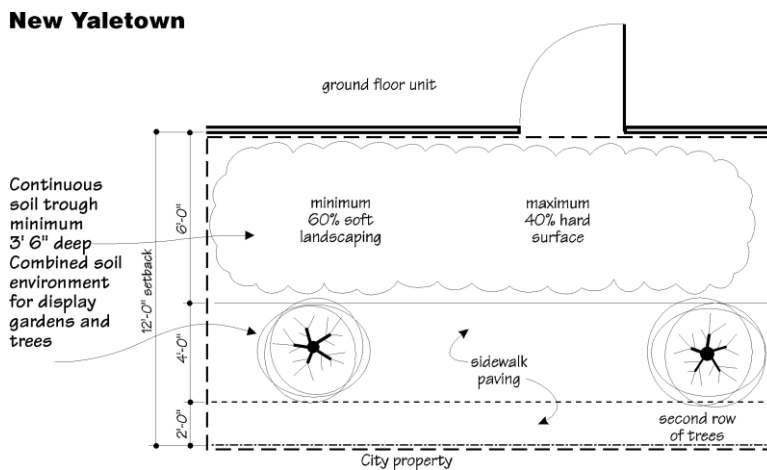

**Figure 42.
Streetscape
Dimensions.**

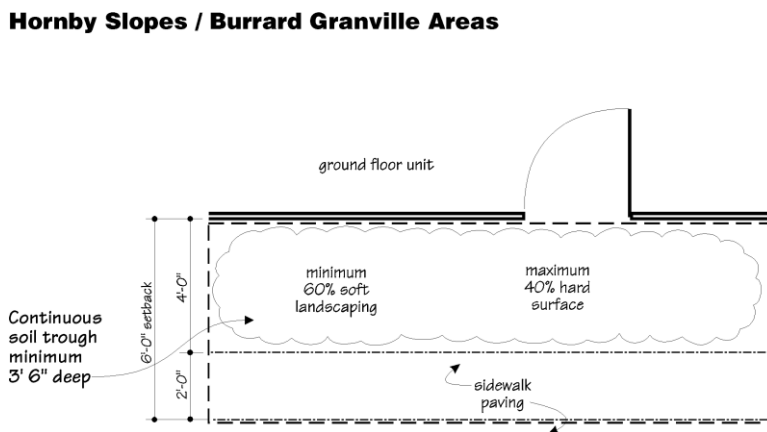

Any variations from the continuity of the street trees, display gardens and useable outdoor spaces will only be considered when associated with a special public purpose.

- (a) Variations may consist of seating areas, features such as public art or water, gathering places, street vending, neighbourhood information boards, bicycle parking areas, glimpses into internal private courtyards or gardens, or doorways and entrances.
- (b) Public gathering places should be visible from both the street and adjacent buildings for informal supervision, however, they should be comfortably separated from adjacent residential windows.

Hard Landscaping

- (a) The garden setback area may be edged by a curb or edging feature constructed of stone, concrete, or brick material and be detailed to relate to the building design. The edging feature should be a minimum of 6 inches and a maximum of 18 inches in height. Installation of a low metal railing on top of the edging feature is encouraged. However edging and rail together should be a maximum of 2 feet high and should not have the effect of screening off the area. (Refer to Figure 40).
- (b) The metalwork of the railing should be sufficiently open to permit a clear view through to the display gardens or useable outdoor spaces behind, and should be designed to incorporate

either a botanical element consistent with the streetscape design or repeat a motif used in the building.

- (c) Utilization of the Downtown South blue-black colour is encouraged for metal work. (Refer to Section 8.1.9.)

Soft Landscaping

The intent of the soft landscaping in the garden setback area is to create variety and visual interest within a generally formal pattern.

The planting of hedges and shrubs that screen the space is discouraged in any landscaped areas between useable outdoor spaces and the sidewalk.

8.1.5 Sidewalk and Tree Grates

Sidewalk

- (a) Setback areas, including useable outdoor spaces, should continue the public sidewalk paving materials, finish, and stamped leaf pattern with a with a 2 foot extension of the sidewalk in the Hornby Slopes and Burrard-Granville areas, (refer to Figure 42) and a 4 foot sidewalk extension in New Yaletown, into which the second row of trees and grates are also set. (Refer to Figure 41). This pattern is also encouraged in the useable outdoor spaces.
- (b) The tool lines should be placed at approximately five foot spacing each way as normally done for a standard sidewalk. Paved areas closer to building edges should have scoring lines at two and a half foot spacing to give a change in density of the sidewalk grid.
- (c) An expansion joint should be located at the property line.
- (d) Special feature paving (including additional granite, different scoring patterns, brass inserts or materials from the building) may be located in the setback areas but only at building entries.

Figure 43.
Typical Sidewalk
Leaf Stamp
Treatment.

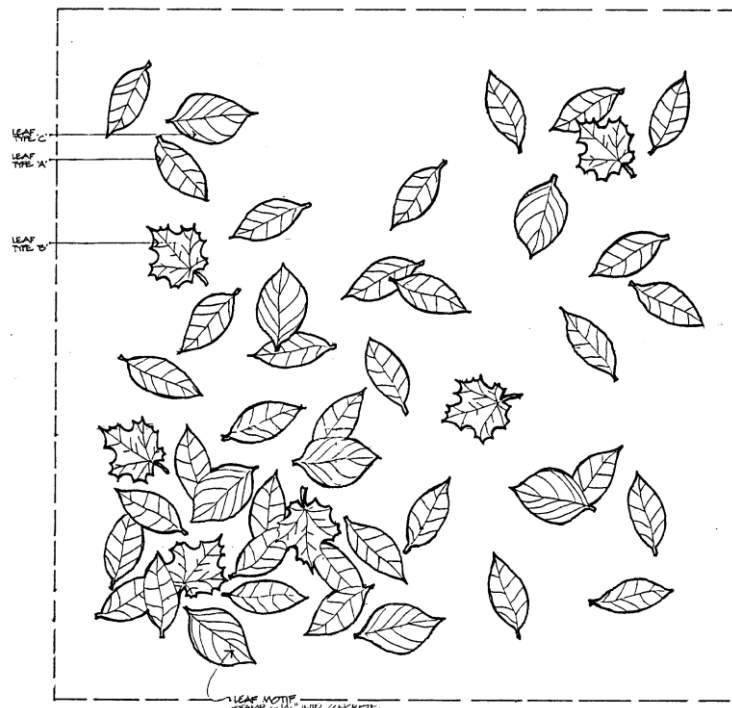

Tree Grates and Surrounds

Tree grates should be made of unpainted cast iron set in a 6 inch wide granite paver surround with bronze floral plates marking the corners. (Refer to Figures 44 and 45).

The combined dimensions of the tree grates and the granite surrounds, measured to the outside edge of the granite surrounds, should be 4'0" by 4'0". (Refer to figure 18).

Figure 44.
Granite Surround
and Tree Gate.

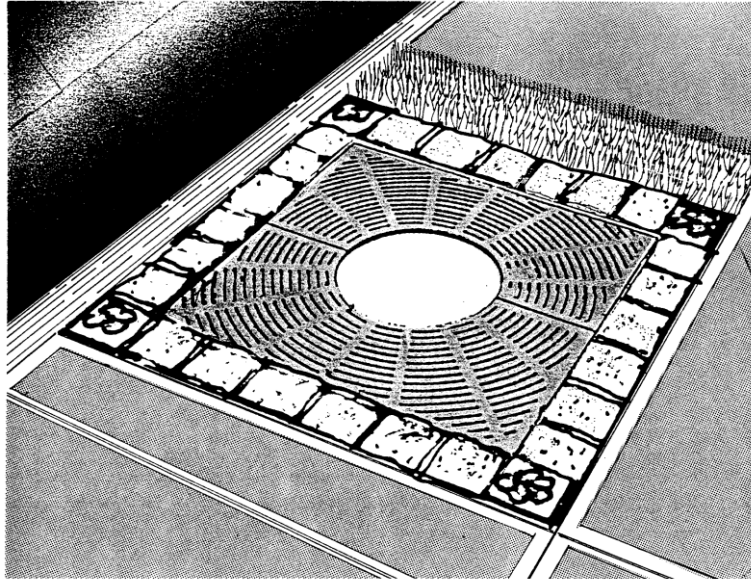
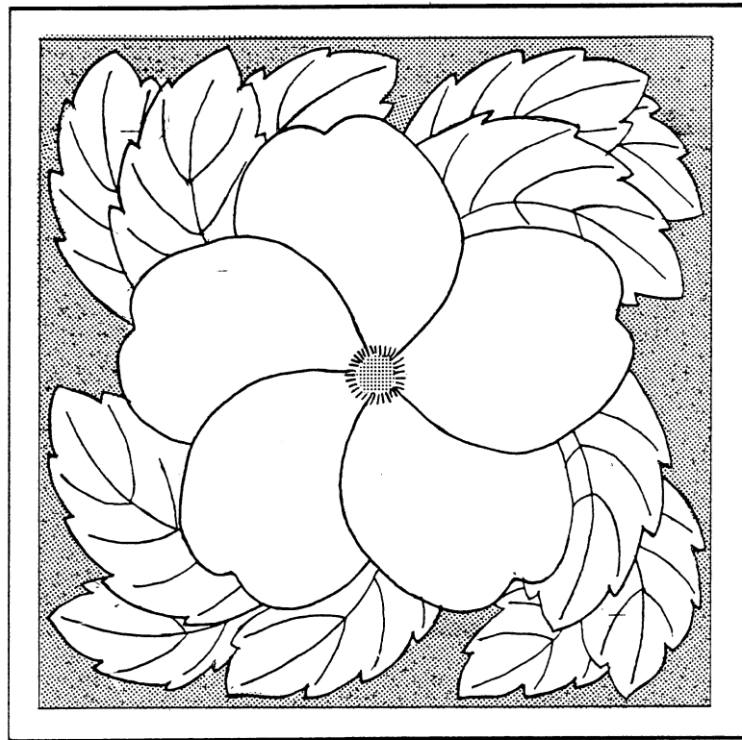

Figure 45.
Bronze Insert for
Granite Surrounds.



8.1.6 Sidewalk Furniture & Bicycle Racks

Within the setback area of the streetscape, sidewalk furniture should be provided by the owners of new buildings. The number and location of each type should be determined in consultation with the Director of Planning. Styles for all sidewalk furniture have been established for the entire area. (Refer to a manual available from the Streets Division of the Engineering Department.) Small bronze flower studs, available through local suppliers, should be set into factory drilled holes on the edges and sides of the furniture to “customize” these stock items consistent with the floral theme. (Refer to Figures 46, 47 and 48)

Where appropriate, recycling containers for such items as bottles, cans or newspapers based on the same design of refuse containers, may also be included.

Figure 46.
Bronze Flower Stud.

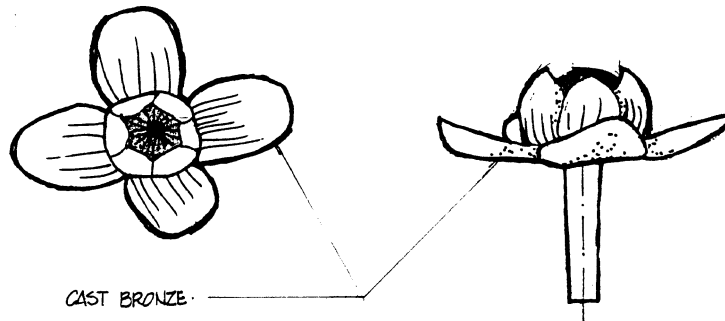

Figure 47.
Bench.

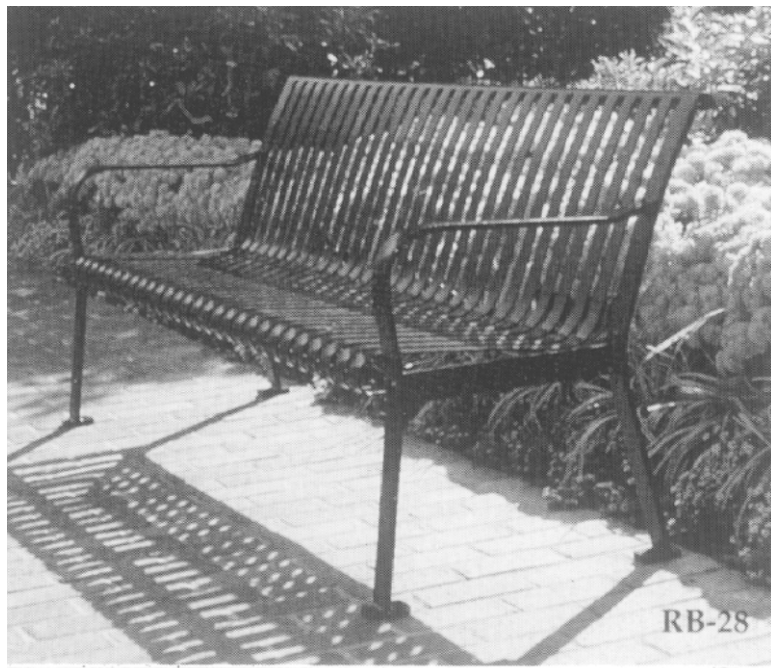
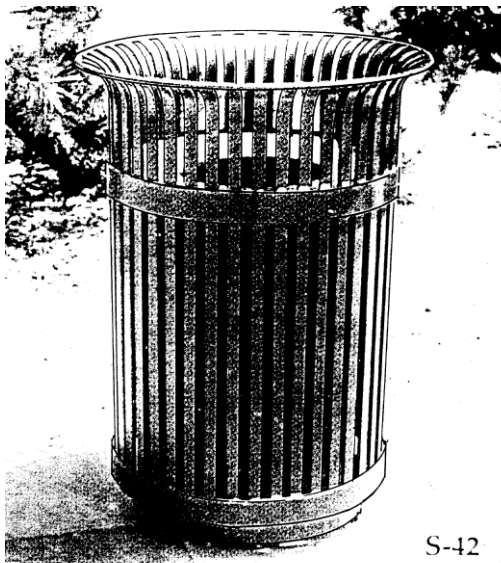

Figure 48.
Refuse Container.



Bicycle Racks

Bicycle racks are to be provided. Choice of bicycle rack design is at the discretion of the applicant but the design should be sympathetic to the rhythm and pattern of the street furnishings. Enhancement of the racks with bronze flower stud motifs is encouraged where appropriate.

Drinking Fountain and Newspaper Vending Machine Surrounds

Detailed designs have also been developed for drinking fountains and newspaper vending machine surrounds in the same flat iron bar style to match the other sidewalk furniture. (Refer to Figures 49 and 50). These items are encouraged where appropriate and should use the chosen design.

Figure 49.
Drinking Fountain.



**Figure 50.
Newspaper Vending
Surround.**

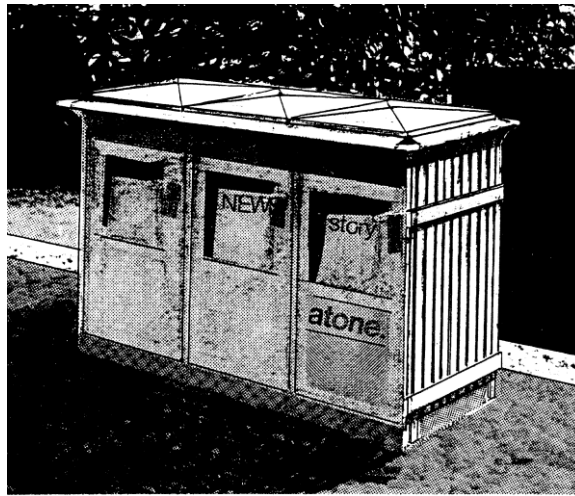

- 8.1.7 **Site Furnishings**
Site furnishings provided in the semi-private open space areas within a project are encouraged to use the same design and decorative motifs specified for the sidewalk furniture.
- 8.1.8 **Pedestrian Lighting**
Pedestrian lighting onto the sidewalk areas should be incorporated into the landscaped setbacks wherever possible to provide additional illumination. The design of these lights should complement fixtures and vine motifs located on City property.
- 8.1.9 **Downtown South Colour**
All painted surfaces, including sidewalk furniture, benches, refuse containers, pedestrian lights, bicycle racks, etc. should use the Downtown South blue-black colour.
- 8.1.10 **Specifications**
Further details and specifications for streetscape design elements are outlined in a manual available from the Streets Division of the Engineering Department. Alternative designs or variations will not be considered.

**Figure 51.
Residential
Streetscape
Character.**



8.2 Streetscape - Retail Areas (Davie Street)

8.2.1 Streetscape Character

Granville and Davie Streets are the retail/service use streets in Downtown South. However, Granville Street is to have a contrasting character with distinct retail and entertainment areas. The following guidelines apply to Davie Street, which is intended to reflect a high level of pedestrian activity, amenity and interest.

- (a) Front yard setback for developments on Davie Street should be 10 feet.
 - (i) The area within the front yard setback is to provide a minimum of 3 feet of unobstructed sidewalk, to serve the anticipated heavier pedestrian volumes.
 - (ii) Retail activities are encouraged to utilize the approximately 7 feet of the privately-owned sidewalk immediately outside their retail frontages for outdoor activities. Desirable activities include outdoor cafes, fruit and vegetable stands, and outdoor displays of merchandise. Restaurants are permitted to construct temporary outdoor enclosures (i.e., fencing, planters, etc.) for outdoor eating, subject to associated regulation, permit, and design requirements. (Refer to figures 52, 53, and 54).
- (b) As in the non-retail areas of Downtown South, public gathering areas are encouraged in appropriate locations. Public uses within the retail setback could include such activities as seating, public art, water fountains, and historic plaques. These public uses should be provided, supervised, and maintained by the adjacent retail operation or building management.

**Figures 52, 53, and 54.
Retail Streetscape
Character.**



**Character prior to
occupancy.**



**Character after
occupancy.**



8.2.2 Trees

- (a) In addition to street trees on City property, trees and substantial permanent areas of soft landscaping are permitted within the privately-owned setback where appropriate. Planters with shrubs, small trees or flowers could be used to define outdoor spaces or to emphasize entries. Climbing vines on building walls can also assist in softening the built environment.

8.2.3 Sidewalk

- (a) City property will be finished as described in Section 8.1.5.
- (b) Private setback areas should continue the public sidewalk paving materials, scoring patterns and finishes with a minimum 3 foot at grade extension of the sidewalk. A 6 inch band of granite at the building wall matching the band around the street tree grates may be provided.
- (c) An expansion joint should be located at the property line.
- (d) Special feature paving (including additional granite, different scoring patterns, brass insets or materials from the building) may be located only at main building entries in the private setback areas.

8.2.4 Site Furnishings

Site furnishings for retail street situations should utilize the street furniture designs developed for Downtown South, as described in Section 8.1.6.

On private property, opportunities to incorporate decorative motifs should be taken on all types of site furnishings. The botanical theme is encouraged to be applied wherever possible in metal railings and litter container surrounds, and in pedestrian scale lighting.

- (a) Where benches are to be provided, guidelines in Section 8.1.6 apply. However seating provided by retail establishments for their customers, especially restaurant or cafe patrons, should be individual moveable chairs and tables.

Garbage and Recycling - (Refer to Section 8.1.6)

8.2.5 Outdoor Retailing and Restaurants

- (a) Outdoor retail display and activities are encouraged within the approximately 7 feet of sidewalk adjacent to retail frontages as a means to substantially increase pedestrian interest. Required weather protection (Refer to Section 5.6) should make many outdoor displays feasible even in rainy weather.

Enclosures (as described below) to create outdoor “rooms” and to permit a controlled space for outdoor dining, are appropriate for areas outside restaurants and cafes, and are subject to all applicable policies, regulations and guidelines affecting the use of public sidewalks.

- (a) Such enclosures should be of temporary and moveable construction, although in practice they may be left in place for a substantial part of the year.
- (b) A wide variety of different types of enclosures may be created; for example, wooden planting boxes with a clipped boxwood hedge; wrought iron railings; pots of colourful annuals; and cast bollards linked by chains or ropes. Good quality construction, assembly and maintenance are important.
- (c) The maximum height of enclosures should be 3 feet 6 inches to permit passing pedestrians to have visual access to the area.

8.2.6 Lighting

It is desirable to have festive and interesting forms of lighting on Davie Street.

- (a) The lighting provided on privately-owned lands in the streetscape should be integral with the architecture and contribute to the character of the street in its design.

- (b) In some instances, it may also be appropriate to use pedestrian-scale lighting at the corners, edges, and/or entrances to enclosed outdoor eating areas to demarcate these places for pedestrians as well as provide lighting for evening dining.

8.3 Streetscape - Pacific Boulevard

- (a) Front yard setbacks for developments on Pacific Boulevard should be determined by adopted building lines, previously approved/existing permanent development, or the False Creek North Official Development Plan.
- (b) Those portions of developments which front Pacific Boulevard should respond in massing, form and character to developments along Pacific Boulevard and/or to the guidelines set out in the False Creek North Official Development Plan.
- (c) Streetscape treatment for developments along Pacific Boulevard should be consistent with the streetscape on Pacific Boulevard. Streetscape treatment of the north/south streets of the New Yaletown area should comply with the Downtown South streetscape design as described in Section 8.1.