



ADMINISTRATIVE REPORT

Supports Item No. 4  
P&E Committee Agenda  
October 7, 2010

Report Date: September 4, 2010  
Contact: Richard  
Johnson/Robert  
Jenkins  
Contact No.: 604.873.7189/7082  
RTS No.: 07591  
VanRIMS No.: 08-2000-20  
Meeting Date: October 7, 2010

TO: Standing Committee on Planning and Environment

FROM: Director of Planning in consultation with the General Manager of  
Engineering Services

SUBJECT: Granville Loops Policy Plan

**RECOMMENDATION**

THAT Council adopt the revised *Granville Loops Policy Plan*, attached as Appendix A to the Administrative Report dated September 4, 2010, entitled "Granville Loops Policy Plan".

**GENERAL MANAGER'S COMMENTS**

The General Manager recommends approval of the foregoing.

**CITY MANAGER'S COMMENTS**

The City Manager recommends approval of the foregoing.

**COUNCIL POLICY**

1975 Downtown Official Development Plan  
1991 Central Area Plan  
2002 Downtown Transportation Plan

**PURPOSE**

This report recommends Council approve the revised *Granville Loops Policy Plan* (attached as Appendix A and referred to herein as the Plan), in order to confirm land use policy in the area, and that staff report back on bicycle facility provisions related to the Granville Loops as rezonings come forward in the area. Minor changes responding to Council direction to the latest draft Plan have been added (tabled at the Transportation and Traffic Committee in January 2009), including further an updated policy related to affordable rental housing, cycling facilities, and further information in relation to building sites which would allow for greater height and density without significantly impacting neighbourhood livability or urban design. All wording changes in the Plan have been shaded.

## **SUMMARY**

Finalization of the *Granville Loops Policy Plan* is important to effectively plan and advance upcoming development initiatives in the area. These initiatives include active private development inquiries, as well as City land development interests in the Loops. Clear land use policy is also important for the general public and in particular, those who live and work in the area. Adoption of the Plan will allow the redevelopment of the Loops to proceed to the next stage of rezonings for individual sites.

In regard to cycling facilities, engineering staff note that the *Granville Loops Policy Plan* enables development of bicycle facilities in the area. For example, the street right-of-ways in the *Plan* allow for local vehicular access and can also accommodate separated bike lanes, if this makes sense in the context of the Separated Bike Lane initiative and the update to the City's Bicycle Plan. Staff will continue to liaise with the BAC as analysis, options, and recommendations proceed.

## **BACKGROUND**

On January 20, 2009 Council Committee received the attached report recommending adoption of the *Granville Loops Policy Plan* (see Appendix B for minutes and staff report). The Committee heard one delegation, the Bicycle Advisory Committee (BAC), and approved the following:

“THAT Council refer the policy report *Granville Loops Policy Plan* dated November 18, 2008, back to staff in order to consider and incorporate as much as possible the recommendations of the Bicycle Advisory Committee.”

The BAC provided further commentary at their May 20, 2009 meeting. These comments were useful in understanding the Committee's concerns related to each of the streets in the Granville Loops area, as well as in the context of the Separated Bike Lane initiative and the update to the City's Bicycle Plan (addressing future bicycle access in the Downtown including the Granville Loops area). It is important that any specific bicycle facilities recommended for the Granville Loops area are compatible with (and be brought forward in the context of) these broader initiatives.

In addition to the cycling related changes to the Plan, there has been additional policy added in regard to affordable rental housing and the identification of sites for potential increased height and density.

## **DISCUSSION**

### **A. Changes to the January 2009 Granville Loops Draft Policy Plan**

1. Minor changes have been incorporated into the document which updates it from the original January 2009 date. In response to public inquiries, commentary has been added in Application and Intent to clarify that the policies are intended for rezonings which may come forward, however, landowners will retain their existing zoning and can still choose to redevelop under the current zoning. Additional information in regard to rental and non-market housing in the Plan has also been added for clarification purposes. This will assist in the evaluation of rezonings which come forward. The new information is found in section 1.3 - Existing Conditions and 2.2 - Overall Concept Description, as well as in a new policy 4.2.3 under Affordable Residential.

2. In response to the January 2009 direction from Council, discussions have been undertaken with the BAC and changes to the Plan are as follows. A variety of bike route options have been added to the *Additional Background Information* section of the Plan. A policy has been added under section 3.1- Street reconfiguration, which states the principle that all options have been kept open for bike

facilities on streets in and on the edges of the Plan for the connection to the Granville Bridge and access through the area.

The rationale for leaving the future design of bike facilities open is threefold. First, given that this is a policy plan, the detailed street design is best left open for the more appropriate rezoning stage when more detailed information is known about specific development proposals in the Loops. Second, the design of the bicycle facilities in and around the Loops would benefit from information from the City's Bicycle Plan, which is due for completion over the next year. Third, in the event there is support in the future for a Downtown Streetcar route along Drake Street, there is appropriate flexibility from a design perspective.

The BAC has recently reviewed the amended Granville Loops Policy Plan and voted unanimously to support the Plan in light of the amendments (see Appendix C).

3. As part of the City's Downtown Capacity and View Corridor Study ("Vancouver Views"), Council directed staff to look for sites downtown that would not compromise important protected public views but would allow for greater height and density without significantly impacting neighbourhood livability or urban design. The Granville Loops sites were analyzed and it was determined that the currently proposed urban design and building forms were optimal for the area in terms of evaluation factors such as shadowing (particularly on key intersections such as Granville and Davie), public views, and building scale. The heights and densities proposed in January 2009 have therefore not changed.

At the same time, sites throughout the rest of the Downtown core were analyzed using the same evaluation factors. A few sites adjacent to the Granville Loops were identified as sites that potentially could take more height within the stated objectives. Two of these sites are just south of the Granville Loops Policy Plan area and adjacent to the Granville Bridge (see Figure 1). When staff analyzed these sites, it became apparent that not only did these two sites meet the policy criteria outlined in the Council directive, but taller buildings on these sites would actually accentuate the 'Valley gateway' urban design principle that has been a main objective of the built form for the Granville Loops area. This is illustrated in Figure 1, with the dotted outline representing the potential buildings on these sites (which are actually outside the Plan area but will be perceived as part of the entry to the City along Granville). These potential higher building developments will be the subject of an additional public process which will be undertaken in the fall and will be reported back to Council as part of the overall implementation of the Vancouver Views Study (anticipated in November 2010).

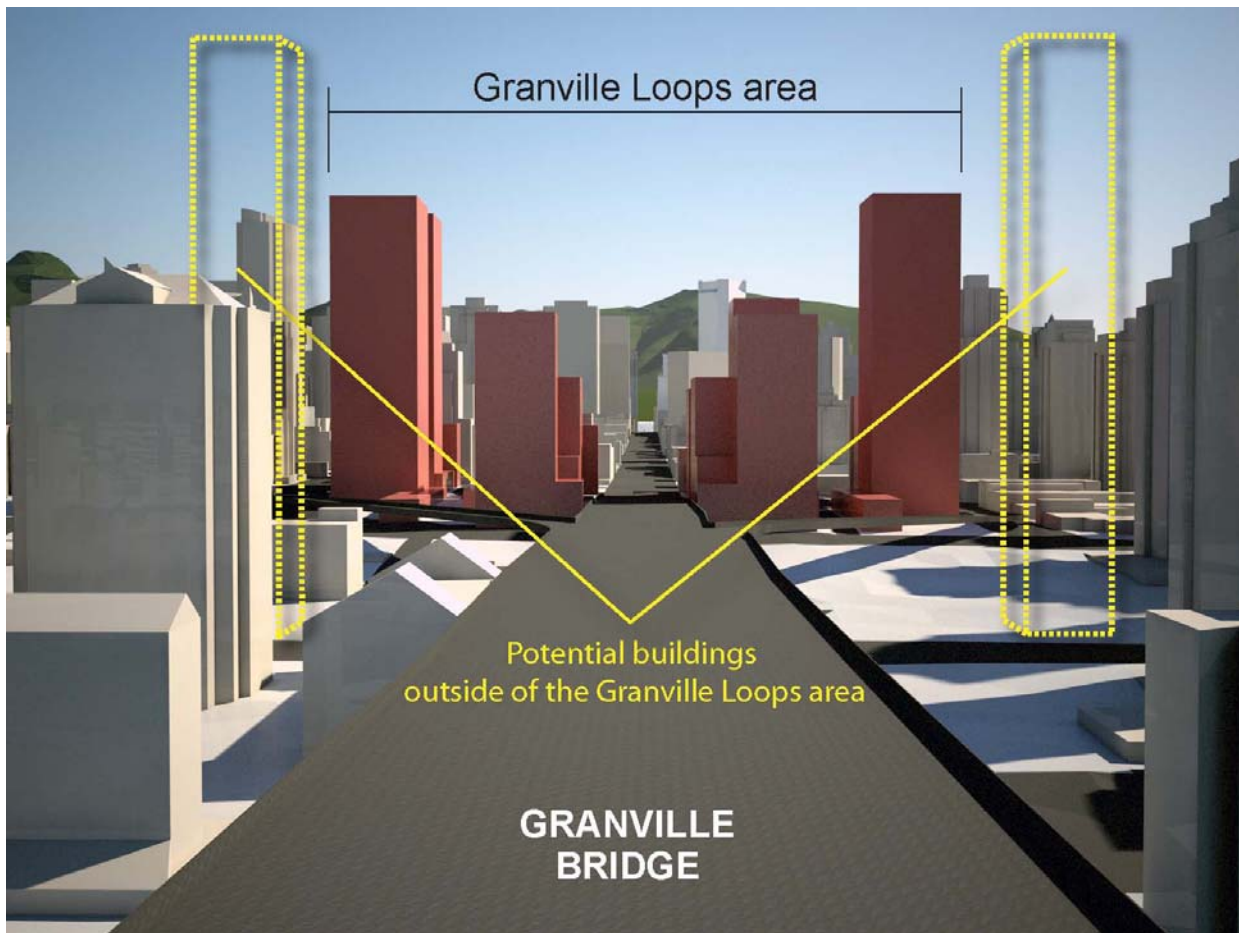

Figure 1 Entry to the City along Granville Bridge

### ***FINANCIAL IMPLICATIONS***

Staff, in the January 20, 2009 report, noted that current analysis, related to the Granville Loops policy area, indicated that revenues raised from the sale of City lands could cover the cost of public infrastructure investments.

A related Granville Loops public benefits approach was approved by Council on January 20, 2009. In conjunction with the first and subsequent City rezonings, the revenues and costs as they relate to public infrastructure and other public benefits will be reviewed and reported to Council.

### ***CONCLUSION***

The *Granville Loops Policy Plan* addresses a broad range of planning matters including Parcel and Street Reconfiguration, Land Use and Density, Built Form and Character, Public Realm Treatment and Public Benefits. Policies in these areas, if adopted, will provide the necessary clarity for how private parcels may be redeveloped through rezonings and the public benefits that will be included. There is also the issue of the City advancing the development potential of its holdings in the area. By adopting the Plan the City can move one step closer in the Granville Loops to the reconstruction of City SRA housing, the construction of pedestrian connections from Granville Street to False Creek, and the development of an improved gateway to the City.

When policies and actions related to accommodating bicycles in the area are finalized in the City's Bicycle Plan, they will be used to guide bicycle facilities design in the Granville Loops area along with

the policies and options contained within the *Granville Loops Policy Plan*. Those policies will be used, along with the rest of the Plan, for evaluating rezonings as they come forward in the area.

\* \* \* \* \*

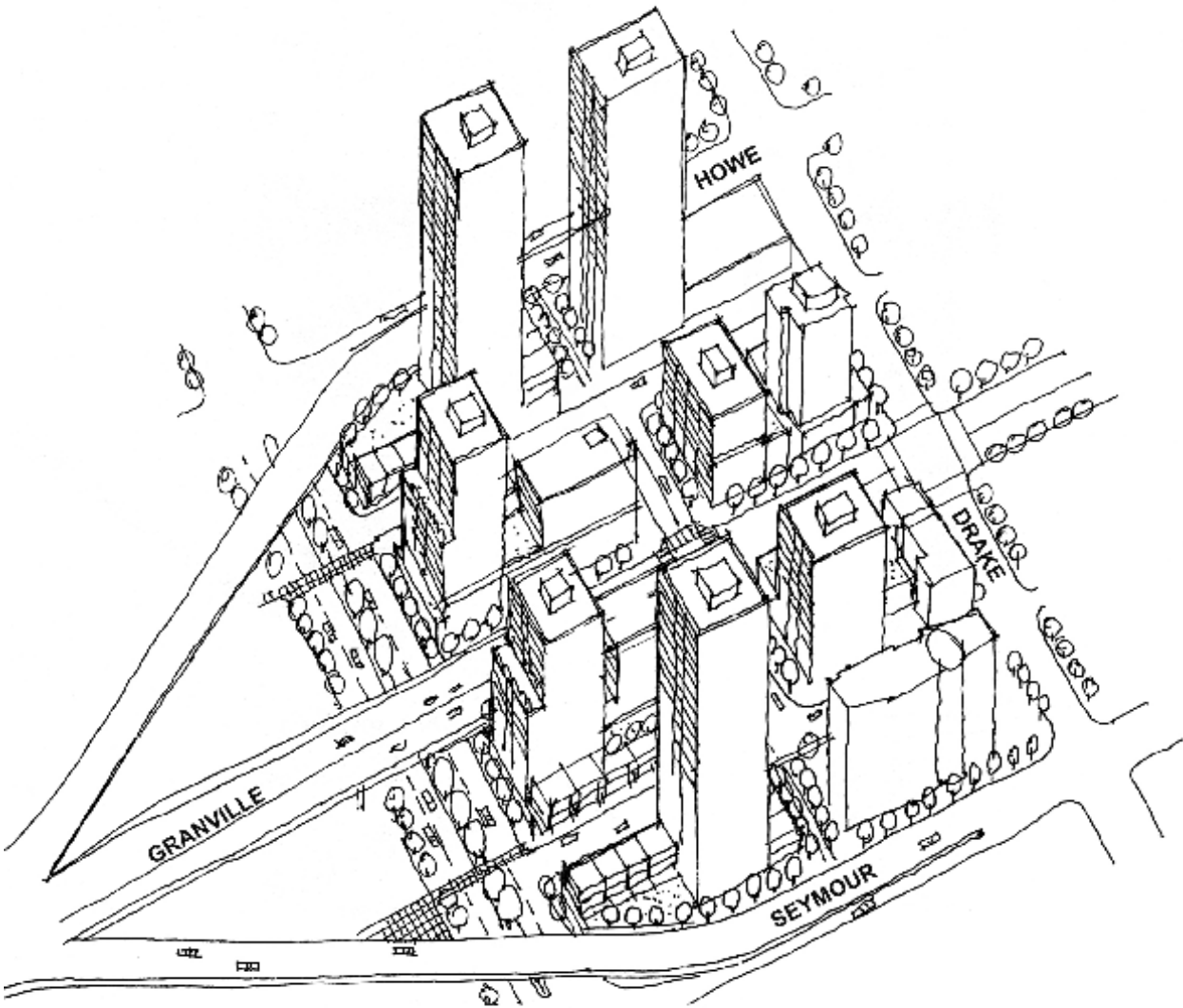

Granville Loops  
Policy Plan  
Draft **October 2010**

GRANVILLE LOOPS AREA POLICIES AND GUIDELINES

CONTENTS

1.0 Application and Intent ..... 4  
    1.1 Purpose ..... 4  
    1.2 Area Location..... 4  
    1.3 Existing Conditions ..... 5  
    1.4 Topography ..... 7  
2.0 Overall Concept ..... 8  
    2.1 Goals ..... 8  
    2.2 Overall Concept Description ..... 9  
3.0 New Streets and Development Sites ..... 11  
    3.1 Street Reconfiguration..... 11  
    3.2 Parcel Reconfiguration and Development Sites..... 12  
4.0 Land Use and Density..... 15  
    4.1 Residential Use..... 15  
    4.2 Affordable Residential ..... 17  
    4.3 Other Uses..... 17  
    4.4 Density..... 17  
5.0 Built Form and Character..... 19  
    5.1 Heights and Floorplates ..... 20  
    5.2 Setbacks and Dedications ..... 22  
    5.3 Orientation and Streetscape Character ..... 24  
    5.4 Heritage..... 25  
    5.5 Views ..... 25  
    5.6 Livability ..... 25  
6.0 Parking & Loading ..... 25  
    6.1 Access ..... 25  
    6.2 Location and Design ..... 26  
7.0 Roads and Utilities ..... 28  
8.0 Public Realm Treatment ..... 28  
    8.1 Streetscape ..... 28  
    8.2 Public Open Space ..... 29  
9.0 Environment..... 29  
    9.1 Green Buildings..... 29  
    9.2 Soils ..... 30  
    9.3 Solid Waste and Recycling..... 30  
10.0 Public Benefits ..... 30  
11.0 Phasing..... 31  
ADDITIONAL BACKGROUND INFORMATION..... 33

List of Figures

1. Area Location
2. Adopted View Cones
3. Existing Conditions
4. Topography
5. Concept Plan
6. Overall Massing Concept
7. Proposed Circulation
8. Parcel Reconfiguration
9. Future Development Sites and Dimensions
10. Grade Level Uses
11. Granville Loops Gateway from Granville Bridge
12. Maximum Heights
13. Building Grade Measurements
14. Streetscape
15. Building Entries
16. Parking Concept
17. Phasing Options



## 1.0 Application and Intent

On July 9, 2002 City Council adopted the Downtown Transportation Plan, which included a direction to reconfigure the traffic loops at the north end of the Granville Bridge in order to improve connections between the downtown and False Creek, and make better use of valuable land.

These Policies and Guidelines embody the plan developed by consultants and a multi-departmental staff team during 2006 and 2007. Their work included detailed road geometrics, massing and urban design studies, and economic evaluation. During the course of the planning, staff has also processed private rezonings on the “Vancouver Centre Lodge” site and the “Yale/Cecil” site, using the evolving Granville Loops Policy Plan.

These policies apply to the properties within the study area that are assumed to have redevelopment potential over the next 15-20 years and wish to rezone from the existing DODP zoning. The Best Western Hotel at 718 Drake and the rental residential building at 600 Drake are relatively new and if they were to rezone within this time frame, staff would have to develop policies for their redevelopment within the context of this plan. Black Top Cabs has approximately 11 years left on its lease in the loops and the plan has a phasing option which allows them to remain in place for that period. It is important to note that the existing zoning remains unchanged and landowners may choose to redevelop under that zoning as opposed to rezoning under the policies found herein as the Granville Loops Policy Plan.

A separate document outlines in more detail the Council-adopted Public Benefits Strategy associated with this area plan.

### 1.1 Purpose

These Policies and Guidelines are intended to guide the redesign of the street system, reconfiguration of land parcels, and redevelopment of the Granville Loops area. They are to be used to:

- guide design and evaluation of future CD-1 rezoning of sites within the study area, and of subsequent development permit applications
- provide information on new street configuration and intentions regarding the public realm
- provide the parameters for future potential disposition and/or sale of the City-owned lands within the area.

### 1.2 Area Location

The area to which these Policies and Guidelines apply is located at the north end of Granville Bridge and is bounded by Pacific, Seymour, Drake, and Howe streets as shown in Figure 1.

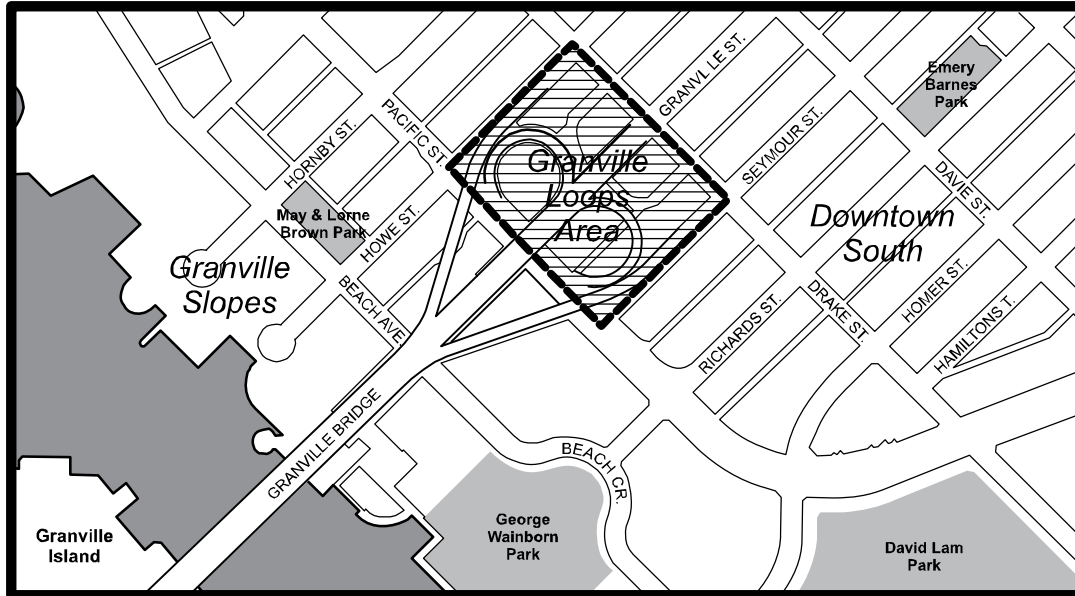

Fig. 1 Area Location

The new streets proposed for the area have been unofficially named East Rolston, West Rolston, and Rolston Way, in order to be able to have reference points. When Rolston Crescent is rebuilt, it is expected that the naming of the new streets will be undertaken by the City's official street naming committee.

### 1.3 Existing Conditions

The area is the "gateway" to downtown Granville Street, an important retail, commercial, and entertainment district with a long history and a unique cultural and physical character within the city. View cones have been adopted that recognize the importance of the vista down this street (see Figure 2). The other surrounding areas are mainly occupied by high density residential development lining important access streets to the downtown (see Figure 3). The topography slopes down from north to south and is complicated by a variety of bridge structures and grades (see Figure 4).

Existing zoning of the Loops area is Downtown Official Development Plan (DODP), Area C, which allows consideration of;

- a range of commercial, cultural, and institutional uses, as well as residential use;
- a maximum density 5.0 FSR overall, with up to 3.0 FSR residential within the total; and
- a maximum height of 300 ft., additionally limited along the eastern side of Granville to a range of 120 to 130 ft. by Viewcone 12.2 (see Figure 2).

Figure 3 shows existing subdivision, uses, and traffic volumes within the study area. There is one building on the Vancouver Heritage Register, the Yale Hotel, listed as a category B building. There are 44 SRA units in the Yale, 106 SRA units in the Old

Continental Hotel, and 50 SRA units in the Cecil Hotel (now closed). In addition, there are 192 affordable small suites in 600 Drake Street on land leased from the City.

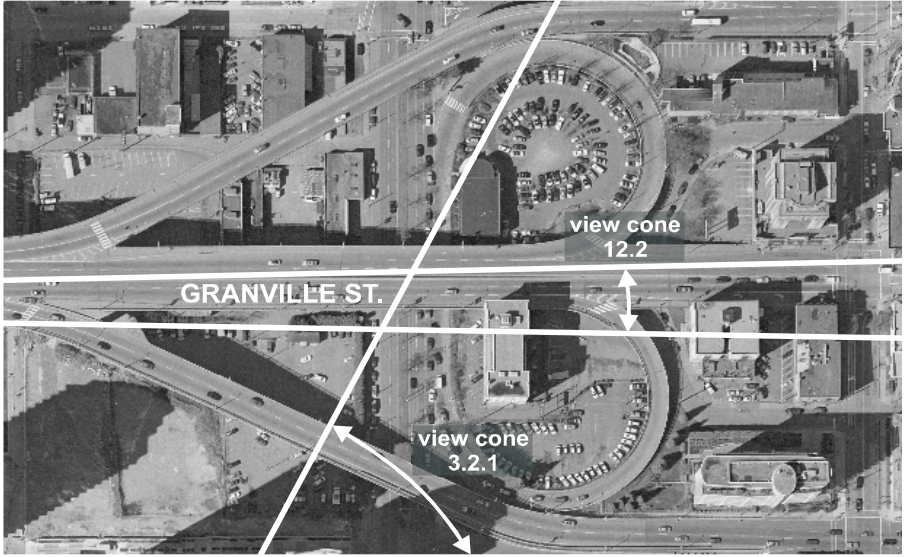

Fig. 2 Adopted View Cones

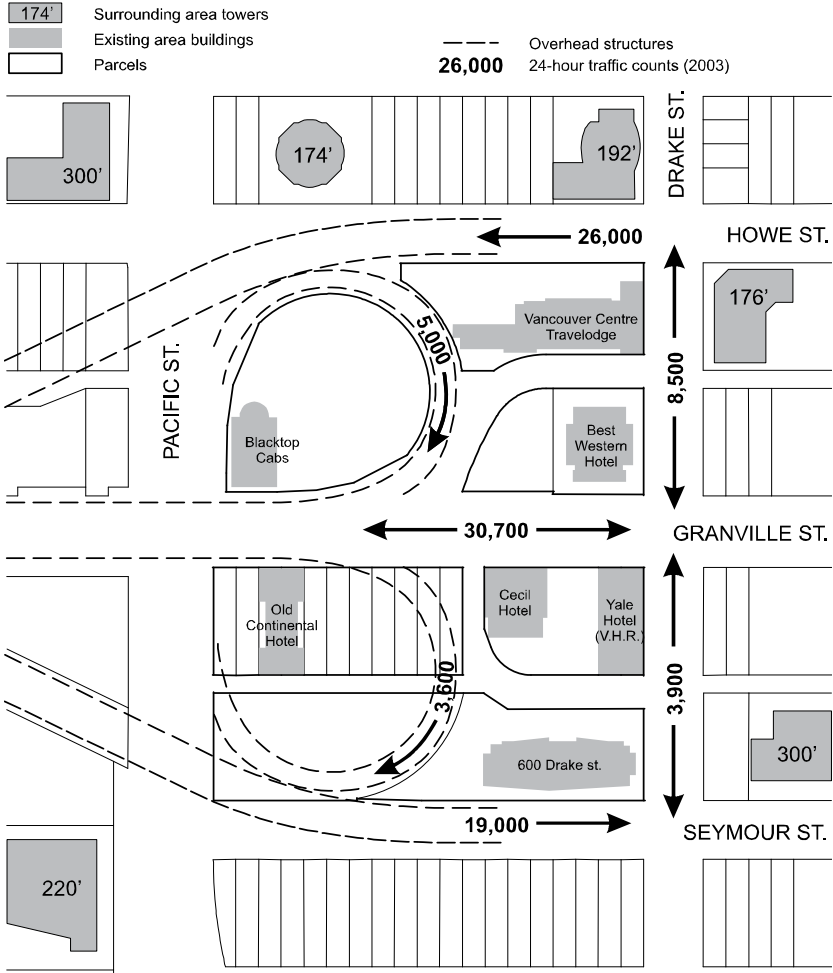

Fig. 3 Existing Conditions

### 1.4 Topography

The topography of the area varies significantly and will influence both building and street design (see Figure 4). However, in this constraint lies the opportunity to reconnect the area in a more coherent fashion by recontouring land and providing a new ground plane.

- 1.4.1 Rebuild Rolston Crescent, partially on fill, to connect up to the existing bridge structure.
- 1.4.2 Allow fill or structures on sites adjacent to the rebuilt streets to connect properly to the new street system.

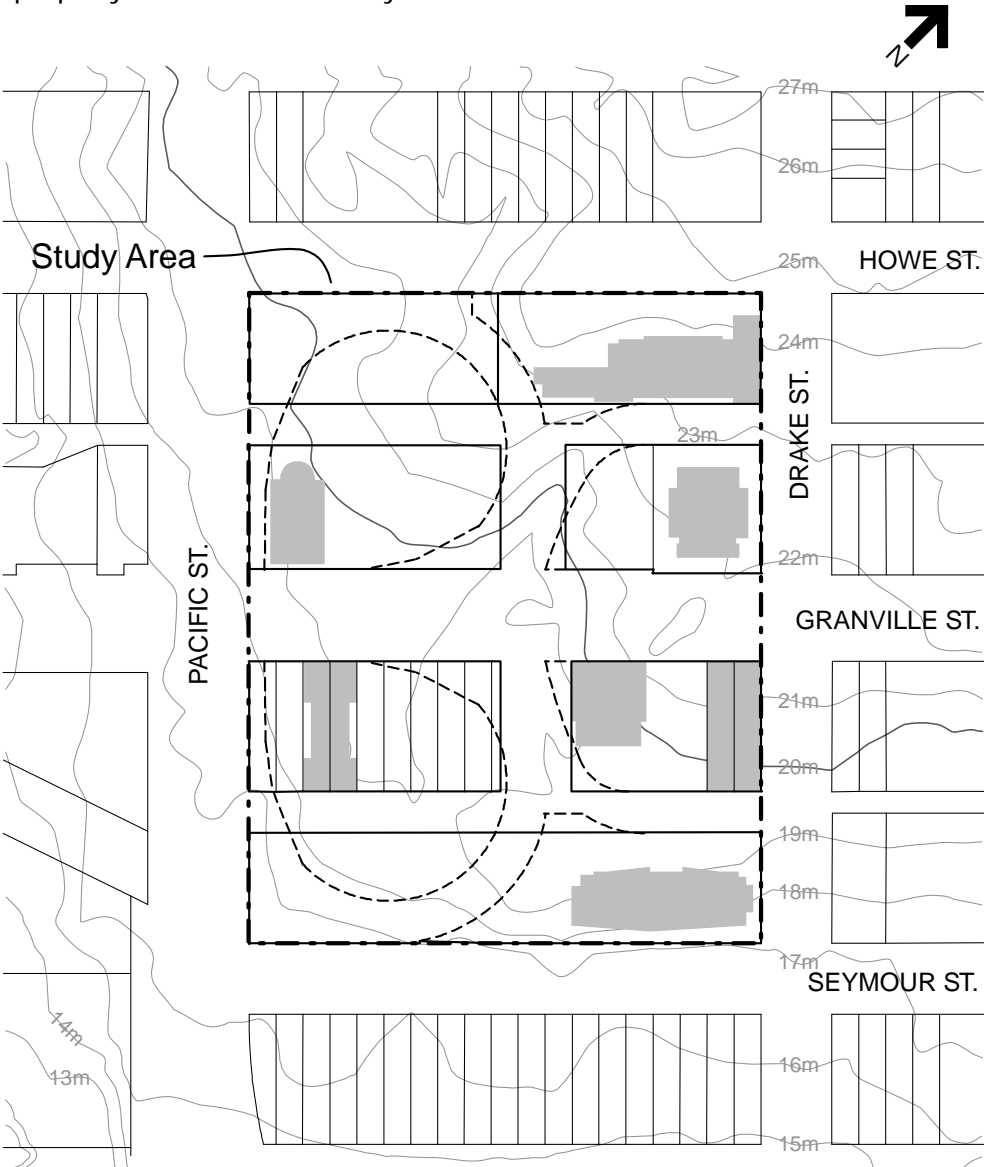

Fig. 4 Topography

## 2.0 Overall Concept

### 2.1 Goals

The overall concept for the area reflects a number of broad goals.

#### Enhance Connectivity

- Reconfigure the streets to allow better pedestrian and cyclist connections from downtown to False Creek by removing the barriers created by the Loops, while maintaining important traffic circulation routes.

#### Create a Distinctive Form and Character

- Create a distinctive built form that creates an improved “gateway” to Granville Street, the historical high street of Vancouver, and major entertainment district.
- Ensure built form that recognizes the scale of the Granville Street corridor but is also compatible with the surrounding highrise Downtown South area.

#### Optimize Land Use and Development Potential

- Rationalize existing parcels and lot lines, as well as facilitate development at densities that are comparable with overall density under existing zoning.
- Emphasize residential use, as in the surrounding Downtown South, Granville Slopes, and False Creek North areas.
- Encourage preservation and/or upgrading of the current private affordable housing.
- Incorporate a replacement for the City-owned Old Continental Hotel non-market housing, and if possible, capacity for additional non-market housing.

#### Improve the Public Realm

- Provide a domestic feel to the new streets in the area by requiring residential use at grade on East Rolston and West Rolston streets.
- Maintain the vitality of the existing streets by requiring non-residential at grade on Granville, Drake, and Pacific streets.
- Improve the existing public realm along Granville, Howe, Pacific, and Seymour pedestrian routes.

#### Allow for Phasing

- Allow for the preservation of existing uses in the area through the potential for a phased redevelopment.
- Allow for new development to occur prior to the new road scheme being constructed.

#### Recover Public Costs and Support Public Benefits

- As far as is consistent with good urban design, achieve densities on City-owned sites that will cover the cost of reconstructing the street/utility system, replacing the Old Continental Hotel non-market housing, and return property value to the Property Endowment Fund.
- Develop a priority list of other public benefits to be supported if rezonings generate additional Community Amenity Contributions.

### 2.2 Overall Concept Description

The concept sees the freeway-like, elevated traffic loops at the north end of the

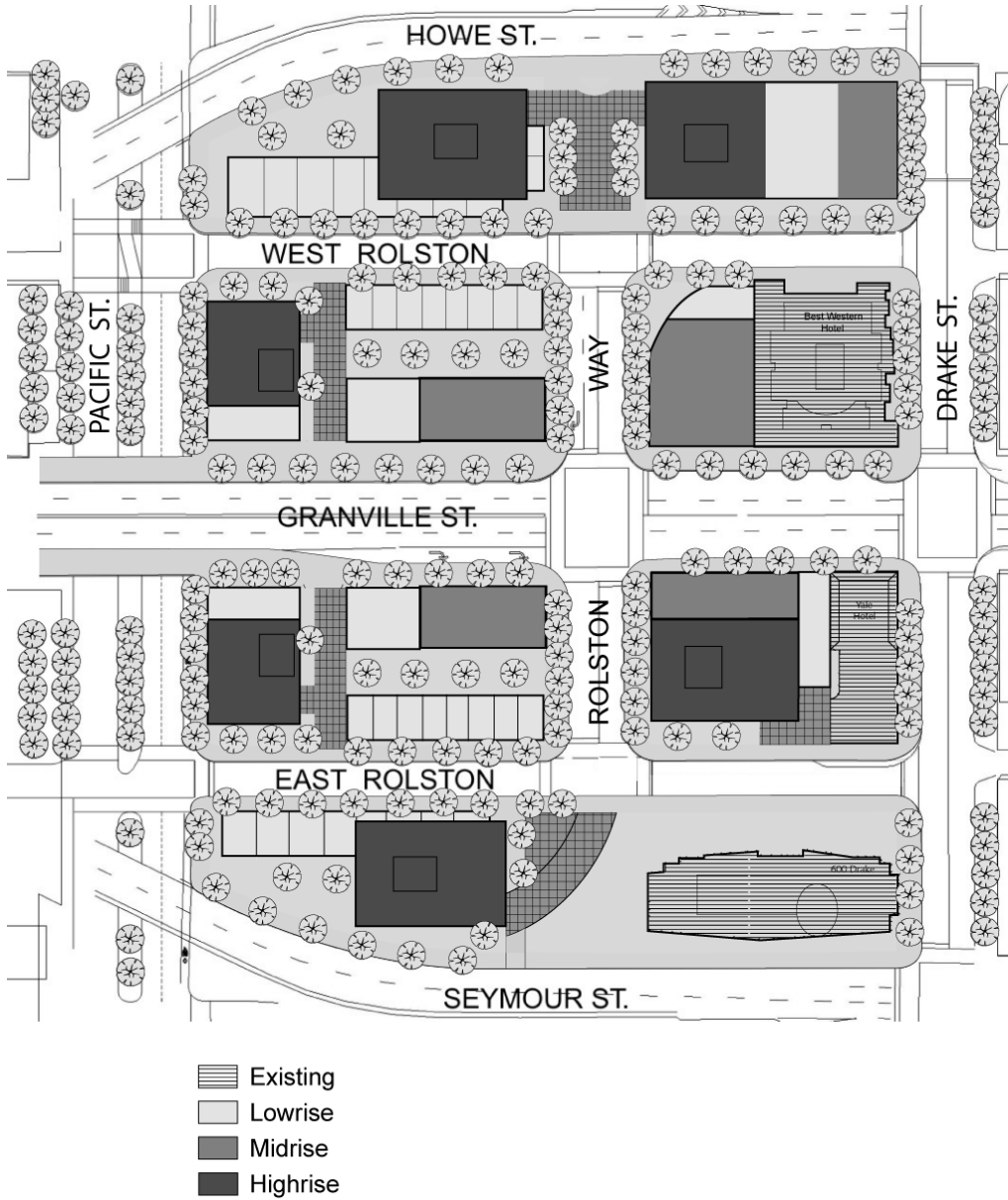

Fig. 5 Concept Plan

Granville loops replaced by an H-configuration of grade-level streets that connect with the surrounding streets and the bridge (Figure 5).

The existing circulation pattern of the loops would be maintained, which is important for access to several areas of downtown, however, the circulation will be accommodated in an urban context. The new East and West Rolston Streets will be narrower than typical streets, but are expected to accommodate anticipated vehicle volumes. Pedestrians will be able to walk down these townhouse-lined streets to False Creek, using improved pedestrian crossings on Pacific Street (Figure 6). Granville Bridge frontages will benefit from a normal streetscape, with larger sidewalks.

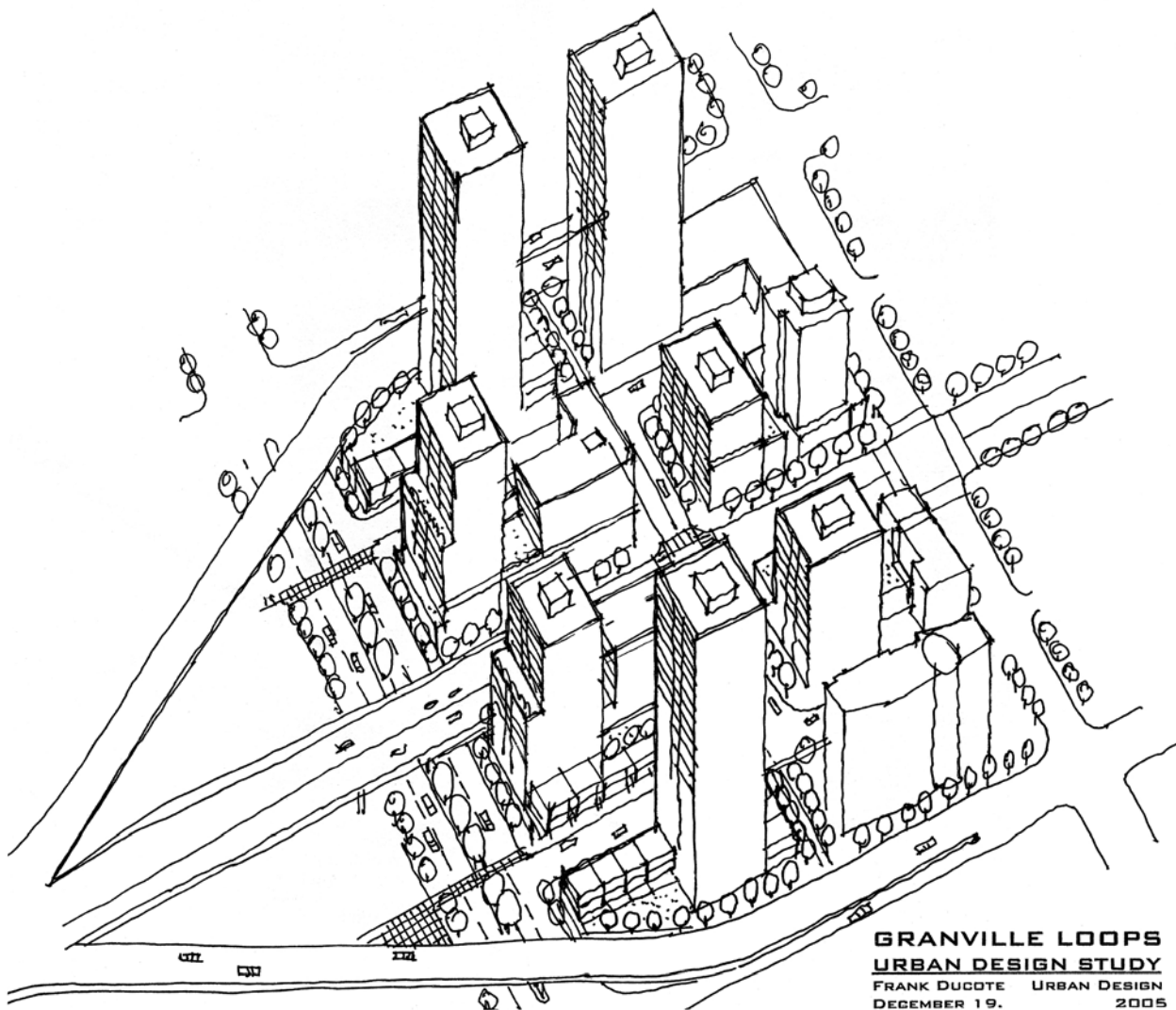

Fig. 6 Overall Massing Concept

The building massing creates a “valley gateway” with somewhat lower buildings on the Granville-fronting sites, flanked by higher towers on the Howe and Seymour edges of the area. This responds to the adopted planning direction for Granville Street further north, which is to ensure that the corridor retains its distinctive mid-rise scale. The paired taller towers are currently recommended at 300 ft. While this is a similar maximum to the surrounding area, given the scale and location of nearby towers, these two new buildings will be quite prominent in marking the entry to downtown. (As noted in Section 5.0, there is the future possibility of considering additional height on these two sites, pursuant to further planning related to heights in the downtown generally.)

The land uses reflect those in Downtown South, emphasizing residential but requiring commercial along the Granville frontage. In all, there could be about 1 million square feet of new development added to the approximately 200,000 sq. ft. of existing development that is anticipated to remain in the Best Western Hotel, 600 Drake, and the Yale Hotel. This will mean that the current area population of approximately 400 residents housed in roughly 350 units, will rise to about 1500 residents housed in 1300 units. Out of the 1300 units, 25-30% will be non-market SRA or affordable rental units (split approximately equally between these two types of housing).

### 3.0 New Streets and Development Sites

#### 3.1 Street Reconfiguration

The primary goal of the street reconfiguration is to extend the City’s street grid system into the site, providing improved access to and through the parcels in the Loops area for pedestrians, cyclists, and vehicles. Although the existing traffic volumes on the loops are relatively light (Figure 3), they serve an important function within the downtown street network. The plan maintains this circulation, but transforms it from a highway form to an urban context.

- 3.1.1 Construct a new ‘H’ street system which connects to the surrounding street grid system, as illustrated in Figure 7. Roadway widths will be narrower than typical, reflecting the existing narrow dimension of the Rolston Crescent right-of-way, and the increased road density relative to a typical downtown block. Two new north-south streets would be formed by the plan: East Rolston would be one-way southbound, and West Rolston would be one way northbound.
- 3.1.2 Provide enhanced vehicular and pedestrian access across Granville and Pacific streets through the construction of street crossings. The Granville crossing would be fully signalized, as would the Pacific crossing at East Rolston.
- 3.1.3 Design pedestrian connections and improvements from Howe and Seymour streets to the new ‘H’ street system, in order to provide alternative connections and upgrade the existing pedestrian environment, as illustrated in Additional Background Information.



- 3.1.4 Consider a reduction of the roadway on Granville Street in front of existing developments south of Drake (Best Western, Yale, and Cecil hotels), in order to achieve wider sidewalks or to establish parking/drop-off bays.
- 3.1.5 Consider the relocation of bus stops in order to rationalize the area to be serviced upon eventual redevelopment.
- 3.1.6 Extend Pacific Street bike routes from east of Seymour Street to Howe Street.

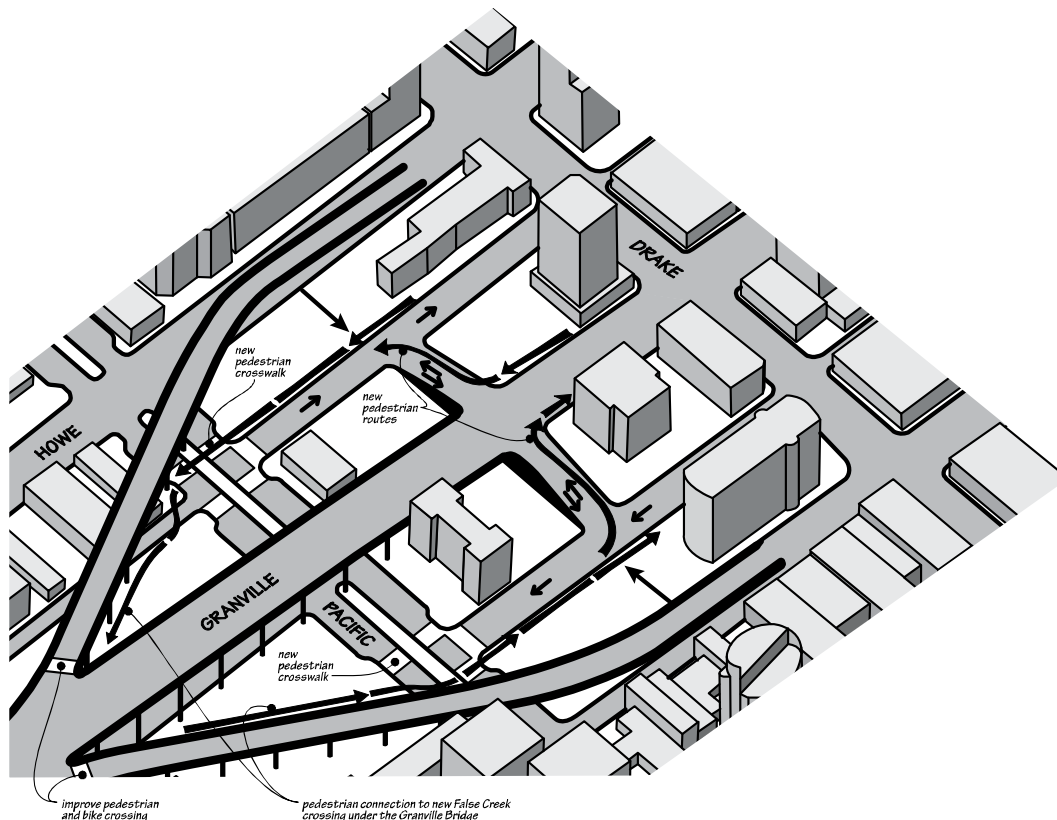

Fig. 7 Proposed Circulation

- 3.1.7 Provide a range of high quality bike facilities, with a preference for separated bike facilities, on streets to be designed, as well as connections to the Granville Bridge and to existing and future bike routes on nearby streets (possible options are shown in Additional Background Information).

### Parcel Reconfiguration and Development Sites

- 3.2.1 Figure 8 shows portions of existing parcels (owned and/or leased) required for the new streets, and areas of current street right-of-way that will be available to be incorporated into development sites. This should be achieved through right-of-way agreements, land sales, and/or dedications. Resulting development site dimensions and dedicated street rights-of-way will be approximately as shown in Figure 9.

- 3.2.2 New development on sites B1, B3, C1, and C3 should dedicate 10 ft. to the Granville Street right-of-way for wider sidewalks and below grade bridge access for bridge inspection and maintenance. Developments should be built to the new property line to provide a direct 'deck' connection from the existing bridge deck to buildings, with no development or parking structure allowed above or below the extended bridge deck.
- 3.2.3 In some locations, surface rights-of-way on development parcels may be utilized (at the discretion of the City Engineer) to allow for additional sidewalk space, especially where parcel size means that parking plates would be seriously impacted by dedication requirements.

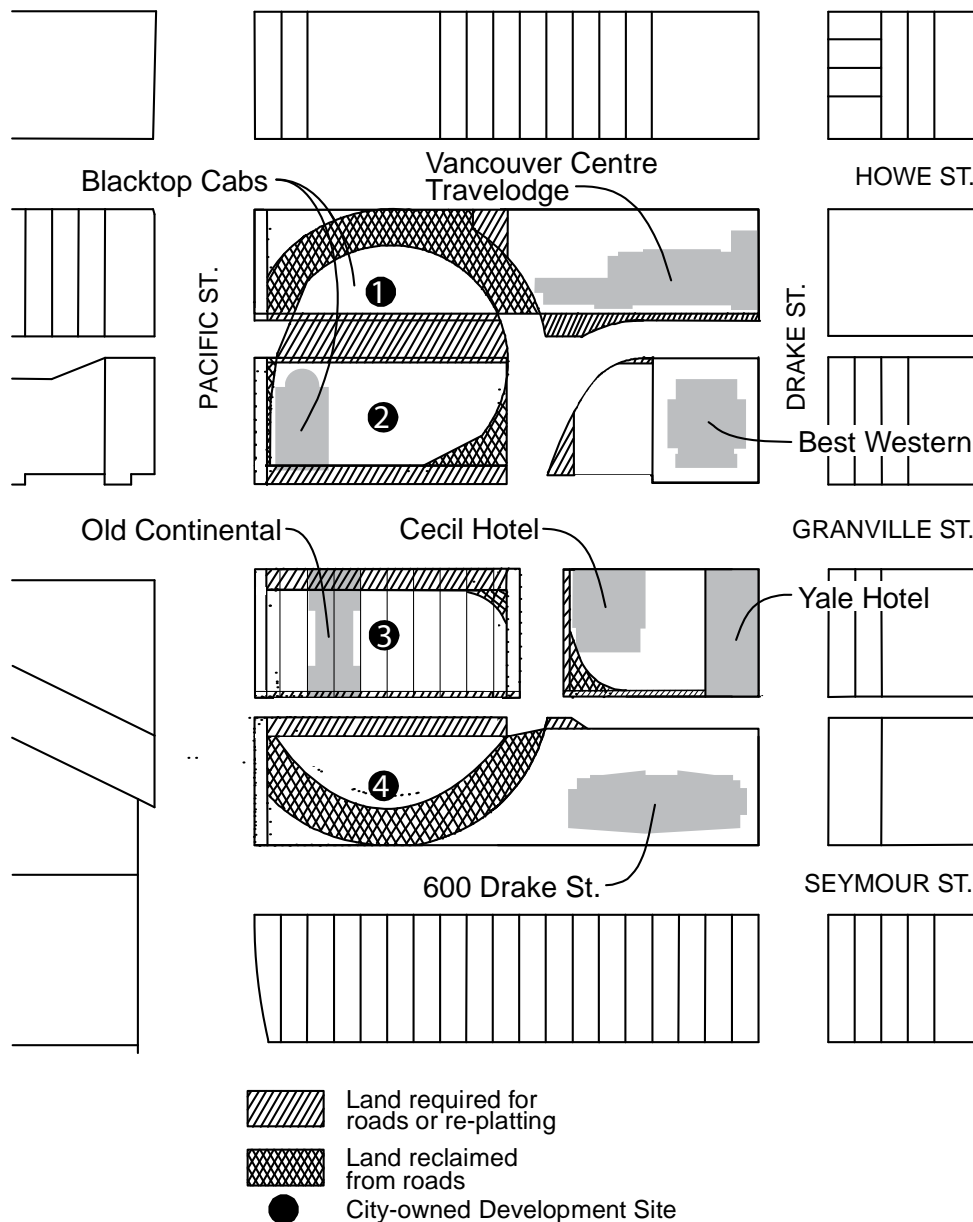

NOTE: Approximate site dimensions in Fig. 9

Fig. 8 Parcel Reconfiguration

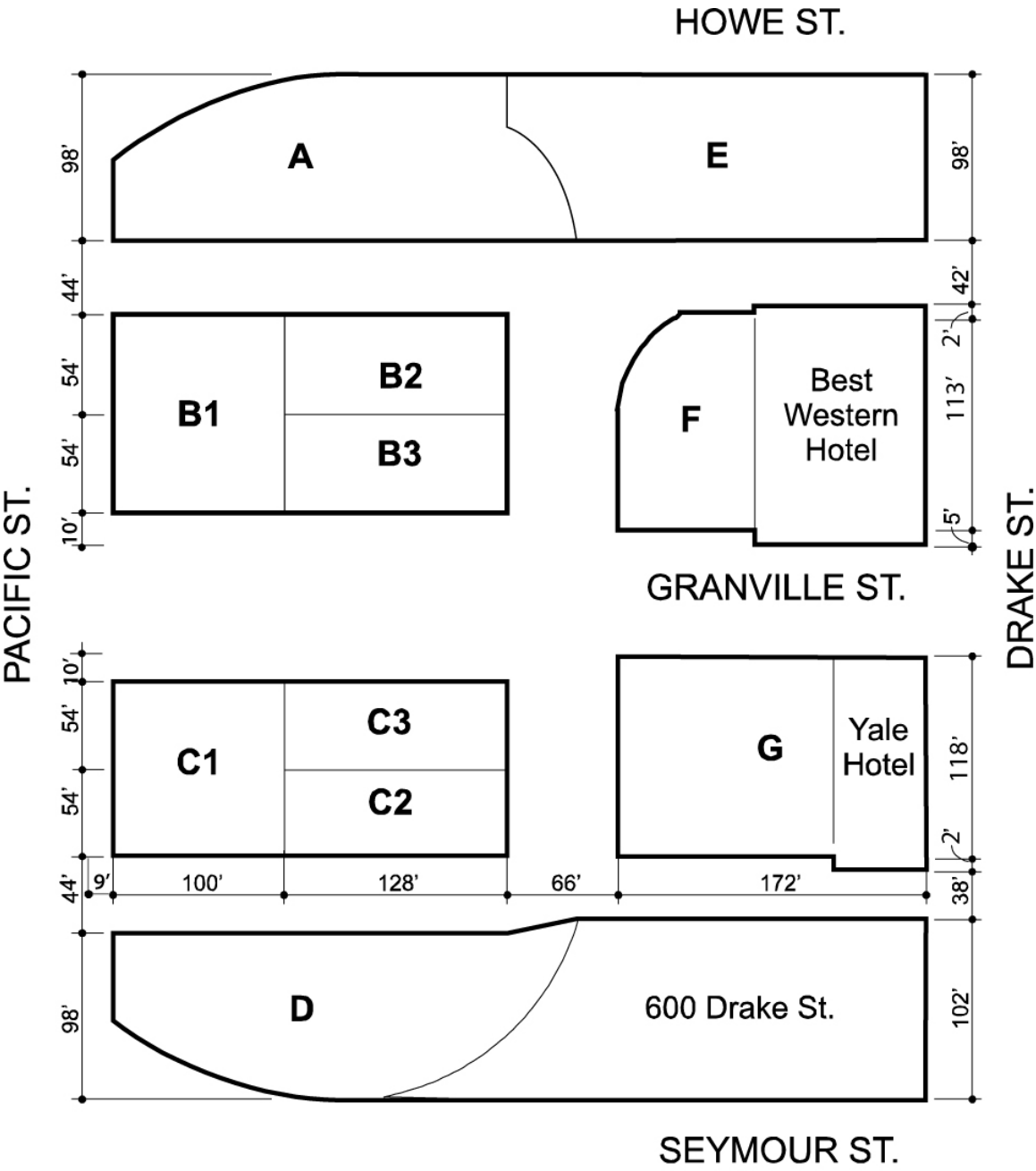

NOTE: B3 will be retained as the replacement site for the old Continental Hotel.

Fig. 9 Future Development Sites  
(Approximate dimensions; subject to detailed confirmation, right-of-way requirements, etc.)

## 4.0 Land Use and Density

The current zoning allows a wide range of uses, but limits residential use to 3.0 FSR within the total maximum 5.0 FSR. These policies focus on residential use, but allow for compatible non-residential uses as well - an approach similar to adjacent areas. Rezoning with significantly more residential density than 3.0 FSR will be considered, within the massing guidelines and floorspace maximums proposed in this document. While non-residential uses are required at grade on Granville, Drake, and Pacific (with the exception of residential lobbies, amenity space, and circulation space), the expected non-residential floorspace will be modest within developments and the area overall. Figure 10 illustrates the ground level uses.

### 4.1 Residential Use

Residential use should be included on all sites in order to meet the overall goals and concept, including the ability to provide an economic return that will support the costs of infrastructure reconstruction and provision of public benefits.

- 4.1.1 Residential uses (except lobbies, amenity space, and circulation space) should not be located at grade on Granville, Drake, and Pacific streets.
- 4.1.2 Residential dwellings with front doors and windows should be located along the new East and West Rolston Streets to the maximum extent possible, in order to achieve the desired domestic feel for the streets.
- 4.1.3 Residential development should meet normal City acoustic standards, and provide an acoustic report. Noise impacts can be mitigated through the use of setbacks, soundproof construction, and/or advantageous unit orientation.
- 4.1.4 Privacy should be enhanced when distances between residential portions of buildings are under 60 ft., through appropriate screening and careful orientation of units.

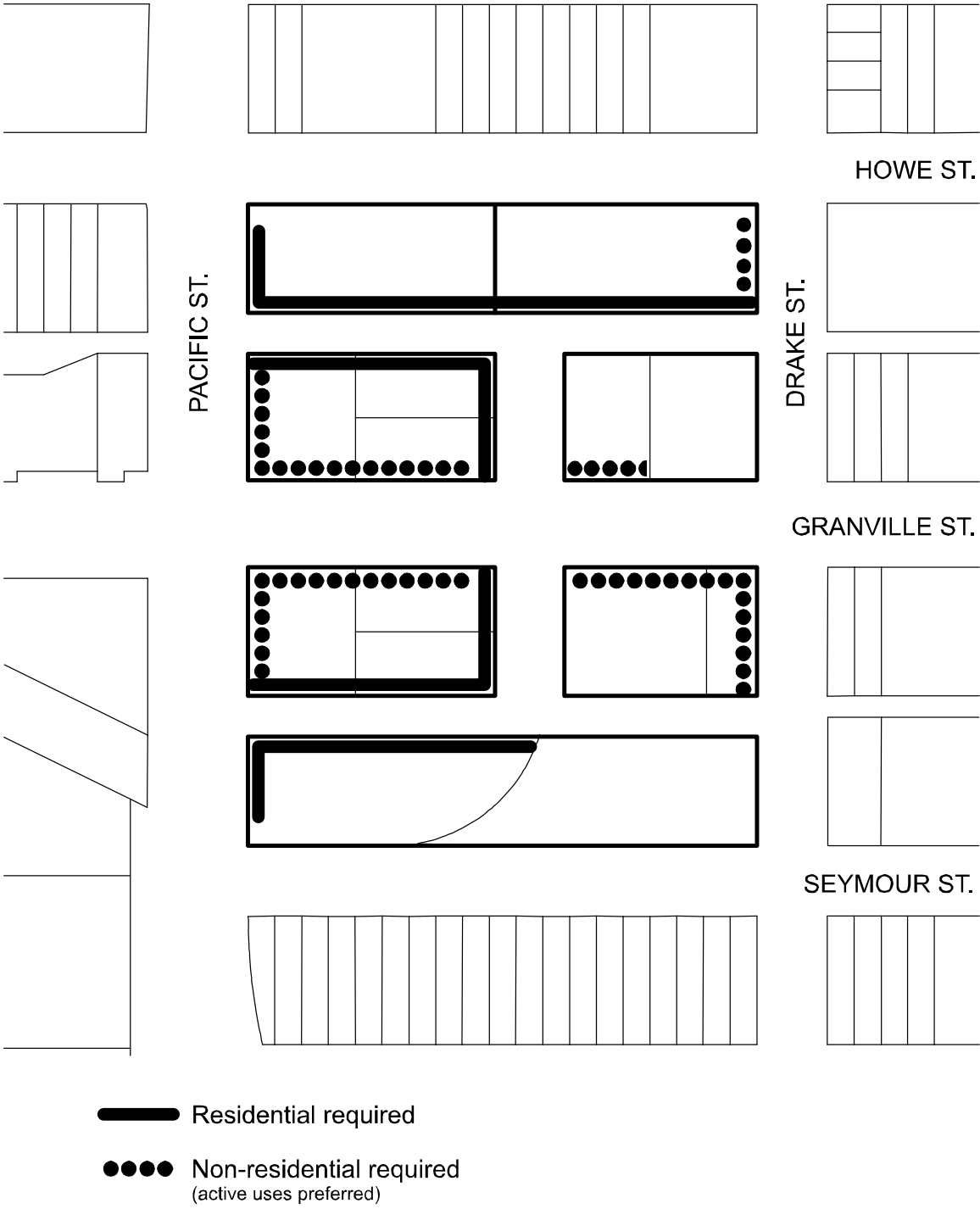

Fig. 10 Grade Level Uses

## 4.2 Affordable Residential

- 4.2.1 Existing non-market housing units at the Old Continental Hotel are to be replaced with new non-market housing on site B3, noting that the standards for unit size and quality will be determined by the City's Housing Centre along with the Social Development Department. Funding will be provided through the redevelopment of the City-owned sites in the Loops. The building envelope on this site is designed to allow for the replacement of all of the units of the Old Continental with significantly larger units than the existing units. Additional SRA units could be provided by decreasing unit size slightly.
- 4.2.2 Private sites with existing SRAs (Yale Hotel and Cecil Hotel) are subject to the Council-adopted SRA Bylaw and policies and have been considered in recently approved rezonings.

4.2.3. Encourage the retention of affordable rental units in the area.

## 4.3 Other Uses

- 4.3.1 The following non-residential uses may be provided at grade or on the second floor on Granville, Pacific, and Drake streets:
- Office uses.
  - Service uses, limited to neighbourhood public house, barber shop/beauty parlour, laundromat or dry cleaning establishment, repair shop-class B, photofinishing or photography studio, restaurants, and business/art schools.
  - Retail uses, limited to adult retail store, grocery or drug store, and retail store.
  - Institutional uses and cultural/recreational uses but excluding arcade, casino-class 1, or bingo hall.
- 4.3.2 Existing transportation uses, limited to taxicab or limousine stations are permitted in below bridge deck locations on Pacific Street.
- 4.3.3 Non-residential uses should be relatively small in scale, with pedestrian-friendly retail, service, or similar uses preferred at grade. While it is not necessary to try and introduce the 25 ft. frontage rhythm called for in the Granville Street (Downtown South) Guidelines for the area further north, any retail or service frontages greater 75 ft. should be carefully designed and detailed.

## 4.4 Density

- 4.4.1 The final determination of the amount of floor space permitted on the various sites will be an outcome of evaluation of specific rezoning proposals that meet these Policies and Guidelines. However, Table 1 provides an estimate of what may be achieved in the massing described in these Policies and Guidelines.

Table 1 Approximate Achievable Floor Space in square feet (Refer to Figure 9 for site locations and dimensions)

	Site Area*	Floorspace
A	20,700	181,000
B	24,600	160,000
B1	10,800	99,000
B2	6,900	11,000
B3	6,900	50,000
C	24,600	160,000
C1	10,800	99,000
C2	6,900	11,000
C3	6,900	50,000
D	20,700	181,000
E	23,350	175,000
F	7,050	43,000
G	20,000	175,000**
TOTALS		
	141,000	1,075,000

\*Site areas are net of dedications, but include surface rights-of-way

\*\* Includes 25,000+/- s.f. of renovated Yale Hotel

Note: Site B3 is the replacement site for the Old Continental Hotel

The amount of development in Table 1 is similar to what could be typically achieved in Downtown South blocks. However, compared to typical blocks in surrounding areas, those in the Granville Loops have a higher proportion of land dedicated to public street. If this area were to have the normal street and lane dedications typically found in Downtown South, the average net density of both existing and future development would be approximately 5.5 FSR. With all of the dedications required in this area, the average net density of both existing and future development is approximately 7.0 FSR. The average net density of just the development shown in Table 1 is approximately 7.6 FSR.

- 4.4.2 Sites abutting Granville Bridge may incorporate parking that is above grade but below the bridge deck. The above table does not include the floor space that will need to be permitted for this parking. The CD-1 zonings should be written to include the appropriate floor space for this purpose. (Floor space used for parking that is located at or below grade is conventionally excluded from calculation, and this should also be the case for these sites where 'grade' will effectively be the bridge deck.)

## 5.0 Built Form and Character

Figure 6 shows the overall built form concept in diagrammatic form, and Figure 11 shows the cityscape as one approaches from Granville Bridge. The intention is to create a “valley gateway”. Lower building massing is located on the Granville sites, relating to massing permitted further north along Granville (90 ft. maximum), with taller towers (300 ft.) on the Howe and Seymour sites, relating to the maximum heights allowed for adjacent Downtown South highrises. The proposed buildings have been located so as to maintain appropriate spacing from existing and potential towers on adjacent sites, to allow for views between buildings, and to preserve privacy.

The towers on sites A and D should be designed to be reflective of each other, but not necessarily copies of each other. This anticipates that they may be built at different times and by different developers. Similarly, the mid-rises on sites B3 and C3 should have similar massing but not be copies of each other. This reflects the fact that one will be market housing and the other will be non-market, on top of the factors mentioned above. The towers on sites B1 and C1 should frame the Granville portal, but the same principles apply for similar massing but also individual expression.

(Note: Heights and view cones in the downtown area will be reviewed during 2009/10 as part of the Capacity Options Review. The objective of the Review is to ensure there is sufficient floor space capacity for future jobs, as well as to support public objectives such as affordable housing, social and cultural amenities, heritage bonuses, and density transfers. The question of whether heights greater than 300 ft. should be considered on sites A and D, to form a more emphatic “gateway”, significantly higher than surrounding buildings, will be considered during the course of this work, which will include public consultation.)

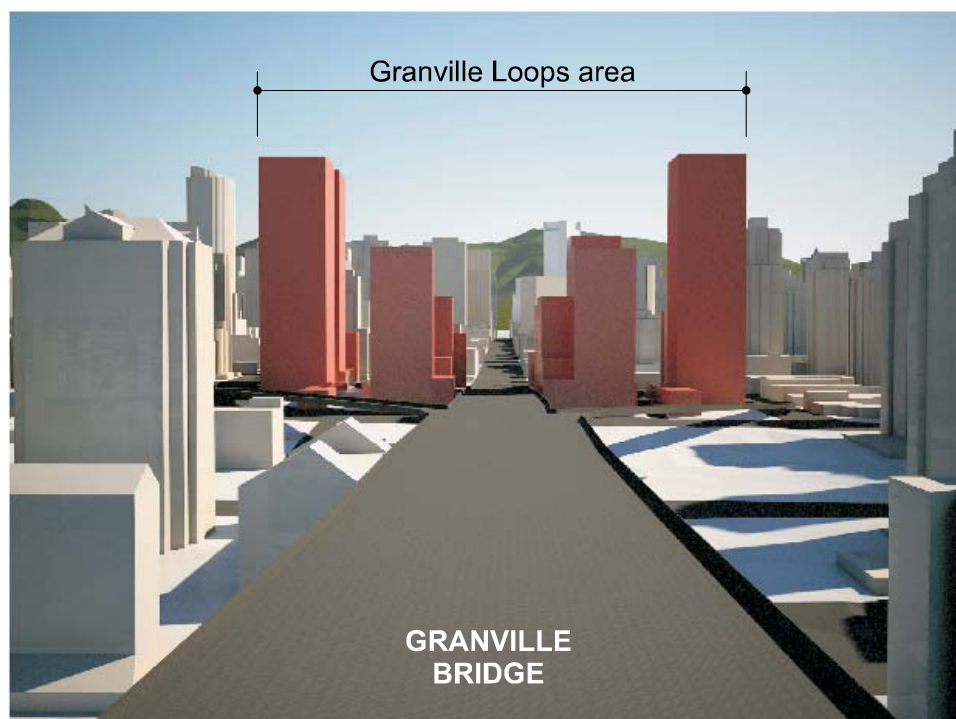

Fig. 11 Granville Loops Gateway  
from Granville Bridge



## 5.1 Heights and Floorplates

5.1.1 Maximum building heights should generally be as shown in Figure 12. Because of elevated structures, sloping ground, and the fact that grades will change in the future, the official building grades in the area are complex. The entire area slopes down approximately 25 ft. from the corner of Howe and Drake to the corner of Seymour and Pacific. For the sake of simplicity, heights in Figure 13 are measured from nominal "grades" as follows:

- Sites B1 and C1 from ground levels on Pacific
- Sites B3, C3, F, and G: from deck or street levels on Granville
- Sites A, B2, C2, D, and E from ground levels on East or West Rolston

In the drafting of the CD-1 zonings the best way to specify maximum heights in the regulations will be determined.

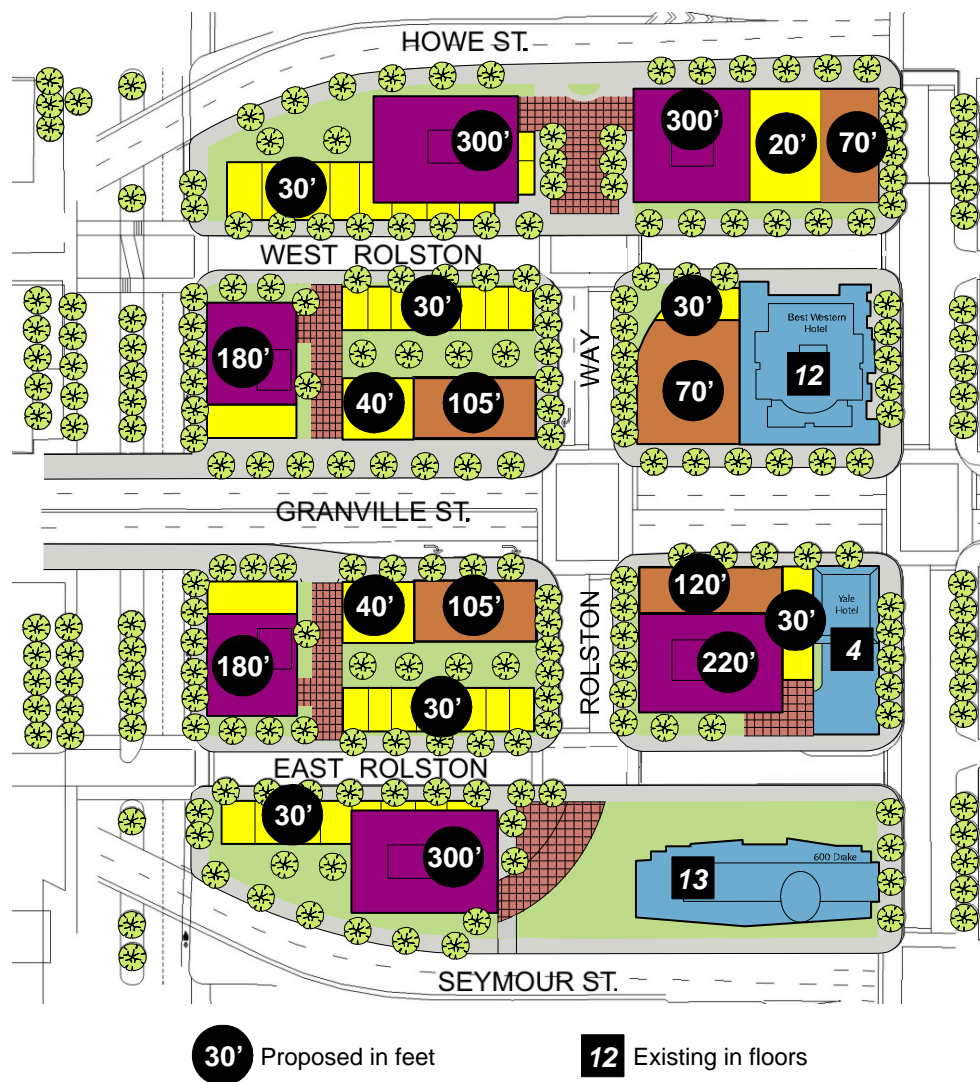

Fig. 12 Maximum Heights

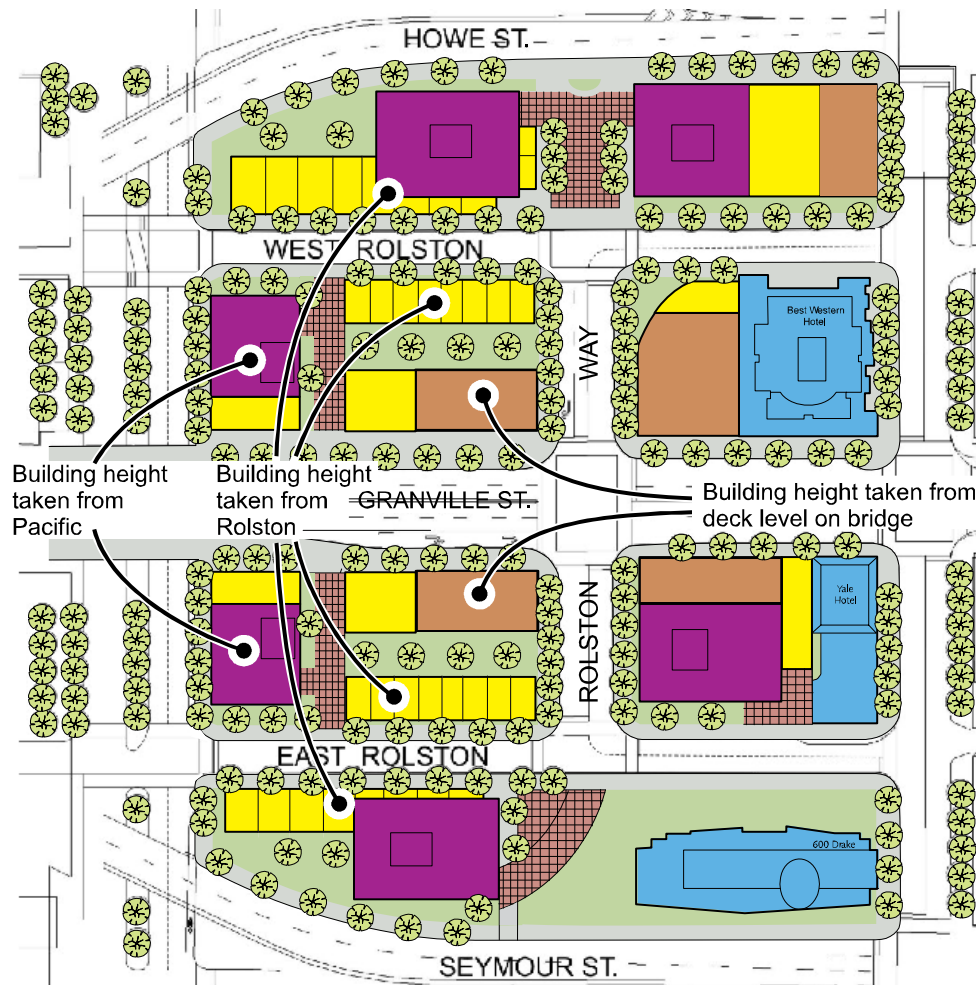

Fig. 13 Building Grade Measurements

- 5.1.2 Flexibility in maximum heights should be considered to a modest extent, where there can be significant improvement in building form as a result.
- 5.1.3 On portions of some sites, building heights will be limited by adopted Viewcone 12.2, as illustrated in Figure 2. Specific calculation of permitted heights will be necessary and all portions of the building will need to be below that level.
- 5.1.4 Streetwall height along the Granville frontage should be a minimum of 40 ft., with the exception of park or public open space.
- 5.1.5 Tower floorplates (i.e. portions of buildings above about 70 ft. in height) should be a maximum of 6500 sq. ft. gross (including elevator cores, storage, stairs, enclosed balconies etc., but excluding open balconies).
- 5.1.6 Flexibility in floorplate maximum should be considered for purposes of achieving non-market housing, on-site heritage preservation, and/or on sites where view cones impose height limits.

## 5.2 Setbacks and Dedications

- 5.2.1 New development on sites B1, B3, C1 and C3 are required to dedicate 10 ft. to the Granville right-of-way, for wider sidewalks and below-deck access to the bridge structures, as illustrated in Figure 14. Developments should be built to the new property line to provide a direct 'deck' connection from the existing bridge deck to the buildings. Design and construction details of the resulting deck platform will be determined at rezoning stage.
- 5.2.2 Granville Street north of Rolston Way - development should generally be built to the property line.
- 5.2.3 East and West Rolston streets - space should be provided in order to allow for provision of 10 ft. wide sidewalks and 4' landscaped setbacks. This space may be secured as dedicated property, surface right-of-way, setback, or a combination of the above, to be determined at the time of rezoning.
- 5.2.4 Rolston Way - space should be provided to allow for provision of 12' and 14' wide sidewalks, with the wider sidewalk on the south side.
- 5.2.5 Howe and Seymour Bridge ramps - buildings should set back 25' in order to provide a landscaped buffer that provides some privacy for residential units, but also opens up the sidewalks next to the ramps for visual surveillance and safety. A 10' setback also applies to the Howe and Seymour bridge ramps to allow for free and clear access to the bridge for inspection and maintenance.
- 5.2.6 Howe and Drake streets adjacent to site E - setbacks should allow for landscaping and/or seating areas, as well as street trees.
- 5.2.6 Pacific Street - sufficient space should be provided to allow for the incorporation of the Council-adopted Pacific Boulevard public realm plan.



make the bridge  
into a street

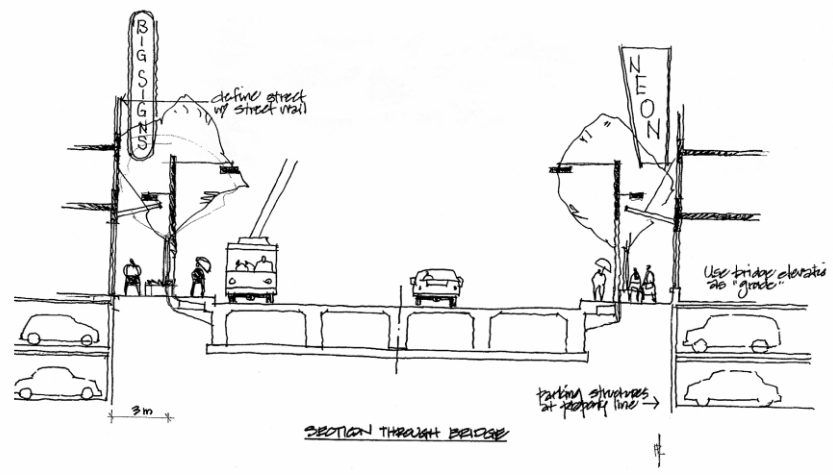

Fig. 14 Streetscape

### 5.3 Orientation and Streetscape Character

- 5.3.1 Pedestrian access to development directly adjacent to the bridge should be required from the bridge deck level as illustrated in Figure 14.
- 5.3.2 Buildings should generally be oriented away from the bridge ramps as illustrated in Figure 15.
- 5.3.3 Main Building entries and secondary entries should be located as illustrated in Figure 15.
- 5.3.3 Ground floor levels of buildings on Drake, Pacific, Howe, and Granville streets should provide visual interest for pedestrians through the use of large windows, detailing, etc.
- 5.3.4 Townhouse dwellings with front doors and windows should be provided to the extent possible along East and West Rolston streets.



Fig. 15 Building Entries

## 5.4 Heritage

- 5.4.1 The Yale Hotel should be retained and upgraded, and receive heritage designation through use of a Heritage Revitalization Agreement. Any bonus density should be accommodated on the site rather than transferred further afield.
- 5.4.2 Granville Street signage should fit in with the heritage character of signage along the street to the north and adhere to Schedule G of the sign By-law for Granville Street - Downtown.

## 5.5 Views

- 5.5.1 New development should be designed and landscaped to provide for attractive near views for existing adjacent developments, as well as for new units.

## 5.6 Livability

- 5.6.1 Habitable rooms must have access to daylight and, as much as possible, to direct sunlight.
- 5.6.2 Developments near odour sources such as restaurants should provide odour mitigation through the use of techniques such as alternative ventilation to opening windows.
- 5.6.3 Private and semi-private open space should be provided where possible, utilizing balconies, roof decks, and terraced spaces on building podiums.

## 6.0 Parking & Loading

### 6.1 Access

- 6.1.1 Access to parking and loading for development sites should be located off East and West Rolston streets.
- 6.1.2 Developments should share access points when possible, in order to minimize sidewalk crossings as illustrated in Figure 15, noting that detailed geometric design will be undertaken for all parcels at the rezoning stage.
- 6.1.3 Convenient passenger drop-off and emergency access should be provided to both residential and commercial uses.

## 6.2 Location and Design

- 6.2.1 Parking should be located at or below grade, in the usual manner. However, on sites B3 and C3 which abut Granville Bridge, parking should be allowed above grade but below bridge deck level, as means of using this otherwise unlivable frontage and as illustrated in Figure 16. Section 4.4.2 above, notes that floor space for this purpose will be included as floorspace in CD-1 rezonings over and above floorspace listed in this plan.
- 6.2.2 Curbside parking should be provided where possible, in order to serve street level businesses and enhance the residential 'feel' of the area.
- 6.2.3 Commercial loading spaces should be designed to minimize visual impact and sidewalk crossings. Off-street or underground loading is encouraged.
- 6.2.4 Effective screening of loading, garbage, and recycling facilities should be provided, especially when considering the lack of lanes and the front address character of the streets in the area.
- 6.2.5 Residential loading should be provided as conceptually illustrated in Additional Background Information.

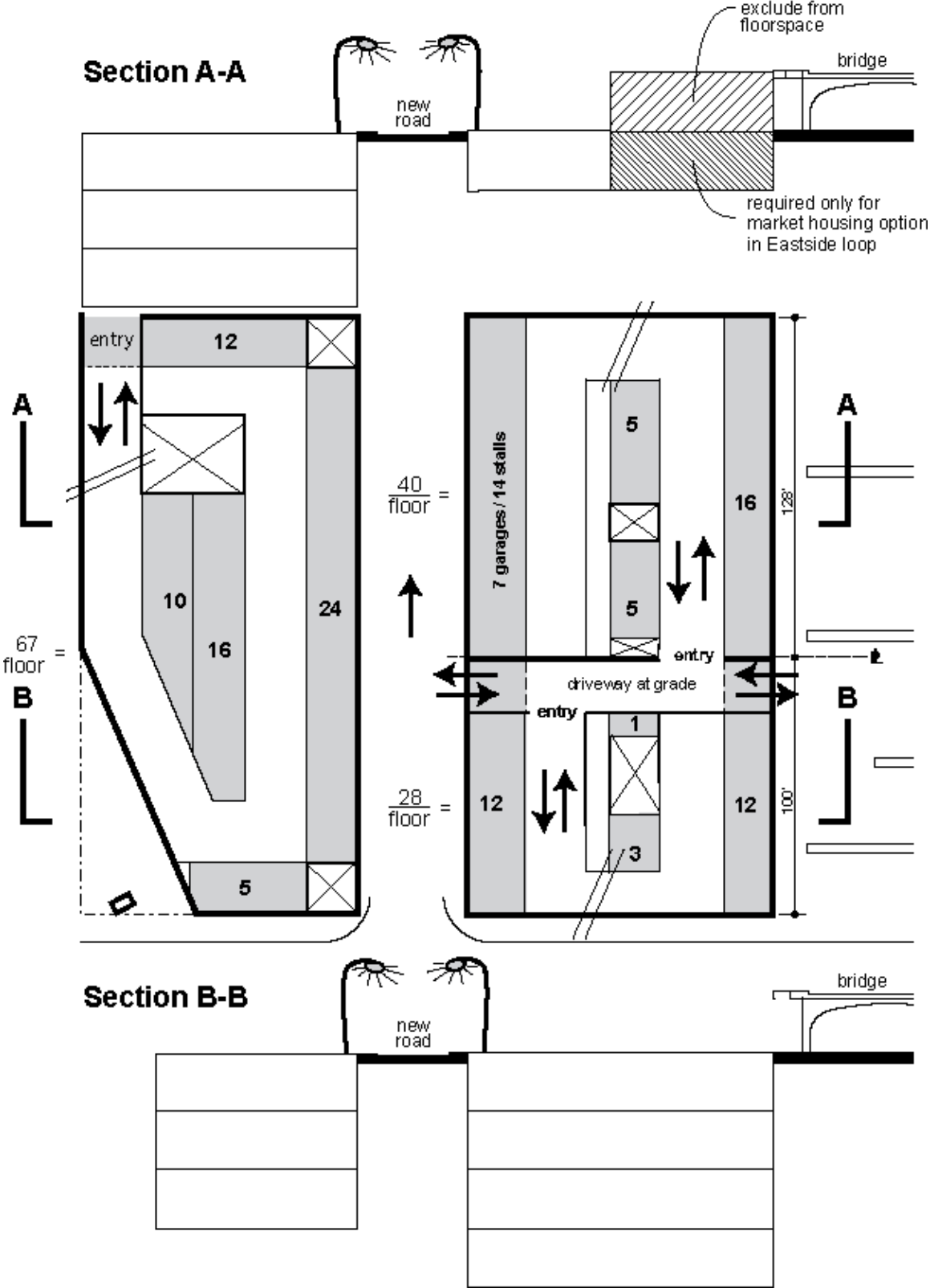

Fig. 16 Parking Concept



## 7.0 Roads and Utilities

- 7.1.1 The new 'H' system street plan will be undertaken as a direct cost of the redevelopment of the City-owned sites in the Loops.
- 7.1.2 Above ground Hydro service should be placed underground where possible.
- 7.1.3 The water and sewer system should be upgraded where required.

## 8.0 Public Realm Treatment

The Pacific Boulevard "Great Street" concept design was adopted by Council in 2005 and is being implemented in stages as adjacent development and funding sources permit. In the area of the Loops, the currently approved design calls for a multi-way boulevard on the south side and an expanded sidewalk and public realm on the north side of Pacific. In addition, pedestrian crossings linking to the "Under the Granville Bridge" project south of Pacific will be required. A crossings illustration is shown in Additional Background Information (Note: refinement to the concept will occur prior to finalization of design).

A reconstruction of Granville Street from Drake to Cordova **was** completed in 2009. It involved a full redesign of sidewalks, street trees, street furniture, lighting, and other street elements. Granville Street in the Loops area will be as compatible as possible with this design.

### 8.1 Streetscape

- 8.1.1 The Howe to Seymour portion of the Pacific Boulevard design should be implemented in conjunction with the development of the new road configuration and development on sites A, B, C, and D. Funding should come from the redevelopment of City-owned sites in the Loops.
- 8.1.2 The design of the public realm for Granville south of Drake to the Howe/Seymour ramp intersections, should relate as closely as possible to the detailed design for Granville Street north of Drake. The opportunity to include street trees on the deck by using planters should be investigated. Funding should come from the redevelopment of City-owned sites in the Loops.
- 8.1.3 Street trees and street furniture should be provided where possible along East and West Rolston streets, as well as Rolston Way, subject to a fully detailed street design for the area.

- 8.1.4 Good vehicular and pedestrian access should be provided across Granville and Pacific streets through fully designed intersections and crossings as conceptually illustrated in Additional Background Information.
- 8.1.5 Pedestrian scale lighting for both on-street and off-street linkages should be provided.
- 8.1.6 The grades of the sidewalks adjacent to the bridge ramps should be improved where possible to provide better lighting, increase security, improve visibility, and provide a smoother transition to the adjacent properties and the mews connecting to East and West Rolston streets. This work should be paid for by the redevelopment of the City-owned sites in the Loops.
- 8.1.7 The Granville Bridge sidewalk extensions are to be constructed as a condition of rezoning of sites B1, B3, C1 and C3.

## 8.2 Public Open Space

- 8.2.1 Public open space on site F should be provided, whether just on the City-owned portion or on the entire site.
- 8.2.2 The mews between site A and E are designed to serve as pedestrian space, vehicular access, and residential loading, as conceptually illustrated in Additional Background Information, and secured by right-of-way agreement.
- 8.2.3 The mews access to site D should provide vehicular access, residential loading, and be designed to incorporate a pedestrian connection to the Seymour sidewalk, as conceptually illustrated in Additional Background Information, subject to a right-of-way agreement with 600 Drake, and secured by an overall right-of-way agreement for the mews.

## 9.0 Environment

### 9.1 Green Buildings

Through revising certain bylaws and regulations, the City has adopted a Green Building Strategy that will see all "Part 3" development achieve a level above the equivalent of LEED Certified, with emphasis on the City's green priorities of energy and water conservation.

With respect to rezonings over the past few years, there has been no Council-adopted Green Building standard. However, many of the major ones have voluntarily met the equivalent of LEED Silver with emphasis on the City's green priorities. Council approved policies in 2008 making this mandatory for all rezoning involving buildings to

which LEED is applicable. The expectations related to Green Buildings are expected to continue to evolve.

9.1.1 Rezoning proposals should meet Green Building policies that are in force at the time of rezoning.

## 9.2 Soils

9.2.1 Provincial regulations regarding soil quality apply. Site profiles, Ministry of Environment approval, and legal agreements may be required for rezonings, subdivision, or development application.

## 9.3 Solid Waste and Recycling

9.3.1 Appropriate garbage and recycling facilities should be provided for both residential and non-residential uses, according to normal City standards.

## 10.0 Public Benefits

The term “public benefits” refers to the range of facilities and amenities that serve or enrich communities, and that the City provides or actively supports. These are:

- Parks
- Community Centres (including ice rinks, aquatic facilities)
- Childcare facilities
- Cultural facilities
- Non-market and affordable housing
- Heritage building retention and rehabilitation
- Libraries
- Pedestrian and cycling improvements
- Public realm improvements
- Neighbourhood Houses

The City has a number of means of funding these benefits -

- Capital Plan spending.
- Floor space bonuses:
  - Some zoning permits consideration of additional floor space to compensate for the inclusion social and cultural amenities or non-market housing;
  - Heritage policies permit consideration of additional floor space to compensate for costs of retaining heritage buildings, as well as floorspace transfers, subject to various limitations.
- Development Cost Levies:
  - DCLs are fixed rate levies that all new development pays on a per square foot basis to contribute to covering the costs related to growth;
  - DCL funding may be spent only on parks, childcare, replacement of low cost housing, and transportation infrastructure (pedestrian, cycling, or transit-related) in fixed percentage proportions.

- Community Amenity Contributions:
  - CACs are voluntary contributions from rezoning projects that help address growth costs, area deficiencies, and/or other community needs and impacts;
  - CACs may be provided “in kind” on site or off site, or may be a pay-in-lieu cash contribution to an amenity.

Development in the Loops area will pay Development Cost Levies, contribute to the Public Art Program, and the rezonings may also have the capacity for Community Amenity Contributions.

- 10.1 Two purposes will have first call on revenues generated from development on the City-owned lands (sites A, B, C, and D):
  - the construction of the **new streets and** public realm, including implementation of Pacific Boulevard “Great Street” improvements from Howe to Seymour, improvements along the Howe and Seymour edges, and the improvements to Granville Street within the Loops.
  - replacement of the Old Continental Hotel non-market housing units.
- 10.2 As noted in section 5 above, retention and rehabilitation of the Yale Hotel should be supported with additional density within the rezoning of site G.
- 10.3 As part of potential rezonings of site E and F, payment-in-lieu of on-site CACs will be accepted to be used in the general area.
- 10.4 Beyond the above policies, a Public Benefits Strategy was approved by Council which allocates CACs from site E (targeting parks and childcare) and sets policy for future rezonings and consideration of potential CACs. It addresses what additional benefits are to be supported based on an assessment of demand generated by the redevelopment, needs in adjacent areas, feasibility of delivering the benefit, and overall funding that is likely to be available.

## 11.0 Phasing

A phased approach may be necessary because of the size, complexity of the street reconstruction, capital funding, and/or existing tenancies and lease agreements. The options introduced (Figure 17) are concepts that will require further staff review if a phasing plan is to be implemented. Private rezonings at 1304 Howe and 1300 Granville have been designed so that they can occur prior to redevelopment of City owned sites or reconstruction of the street system.

The proposed phasing plan is shown in Figure 17 and allows for the east side of the bridge loops to be reconstructed prior to the west side. Site D would be the first parcel available for redevelopment and its sale could potentially fund the loops reconstruction. Option A shows maintaining the existing access point (an underpass below the east loop), whereas Option B shows a new access point to the west loop

which would be an at-grade intersection. The benefit of not requiring the underpass to the east loop is that the easterly portion of Rolston Way could be constructed on fill, in what would be the final design state. It may also be possible in Option B to fully construct Rolston Way (not illustrated) depending on grades, detailed design, and operational issues.

This phasing plan could allow existing tenants to stay in place for the full term of their lease. However, if Black Top cabs relocated prior to the end of their lease in 2022, the phasing would be free to consider the entire Loops area. If this was the case, a new phasing plan may need to be considered to reflect not only the factors mentioned above and the general market conditions, but also the condition of the Old Continental building and the opportunity to replace it on site B3.

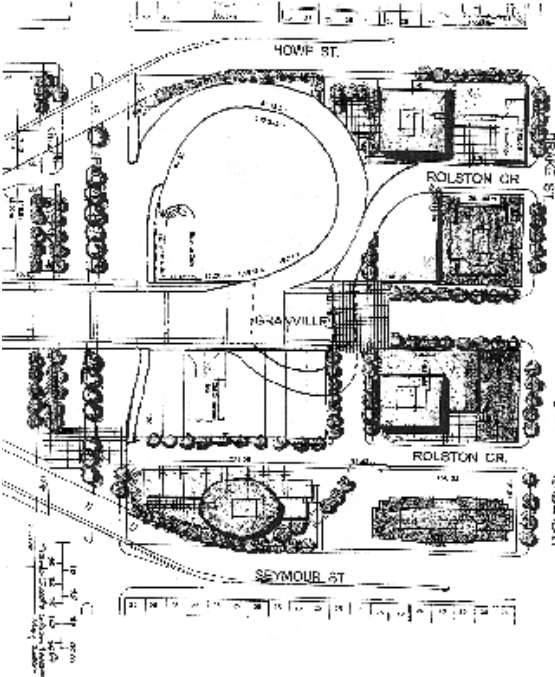

Option A

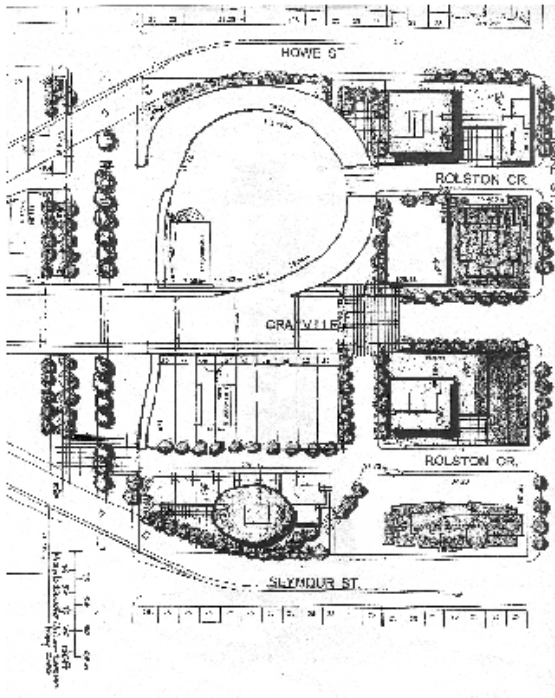

Option B

Fig. 17 Phasing Options

ADDITIONAL BACKGROUND INFORMATION

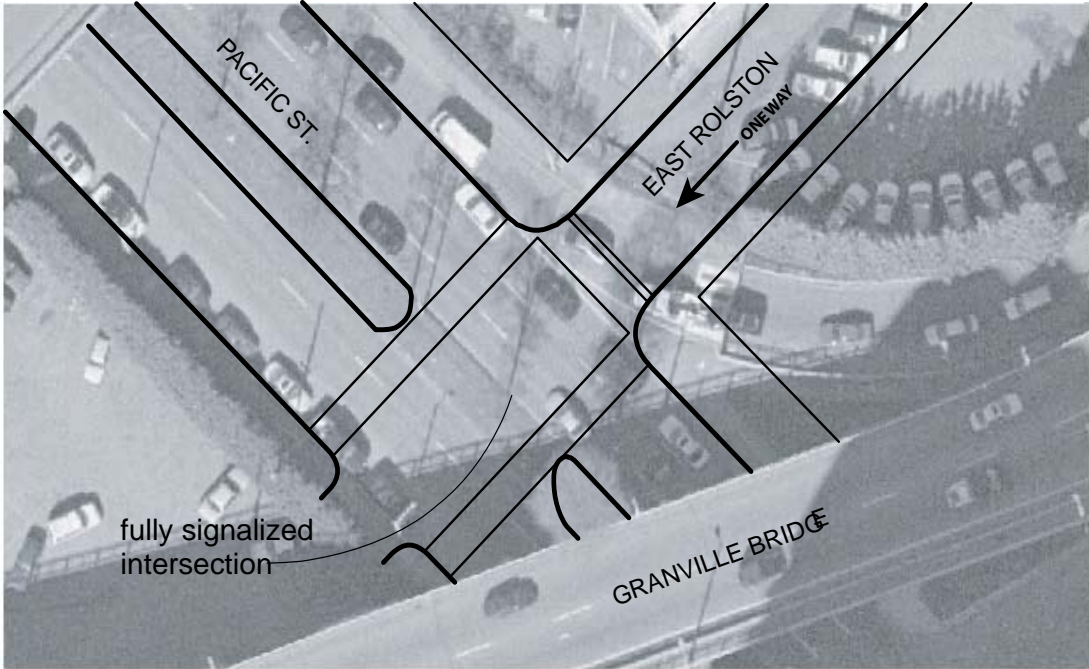
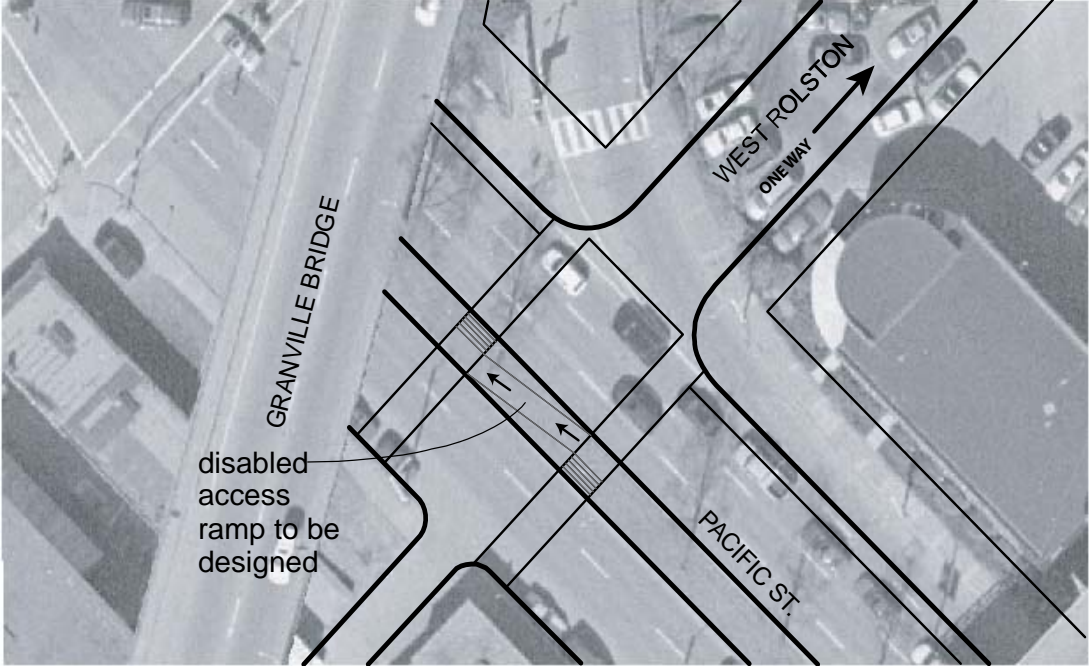

Conceptual Plans for Pacific Crossings

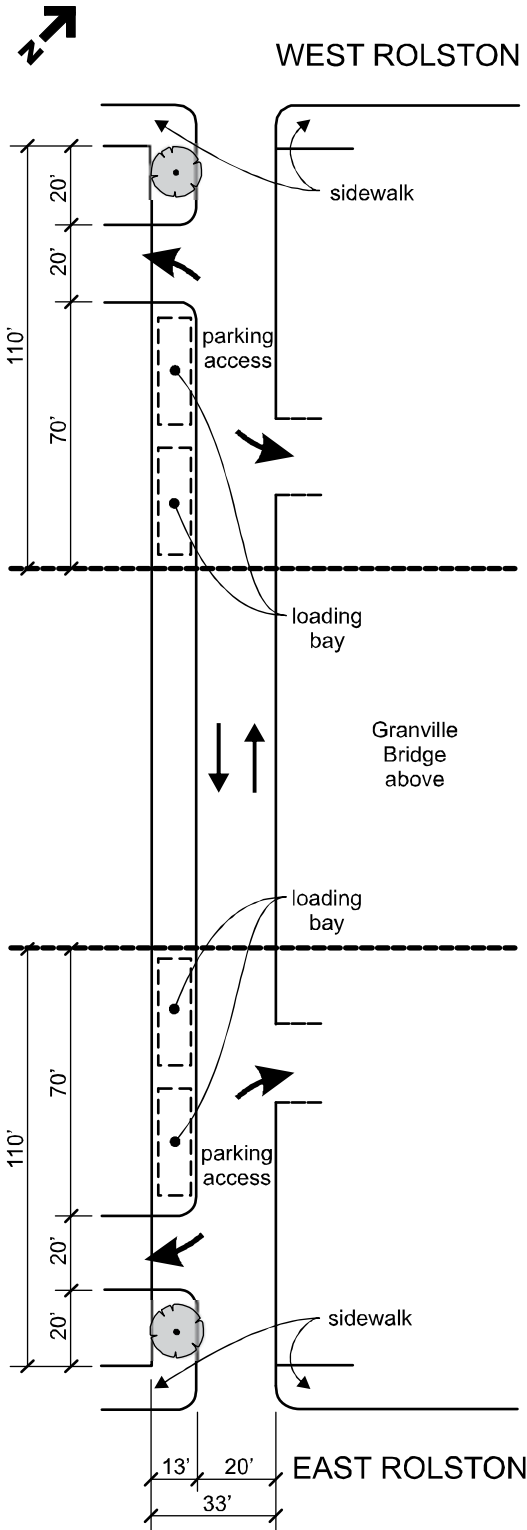

**OFF-STREET ACCESS  
FOR PARCELS B & C**

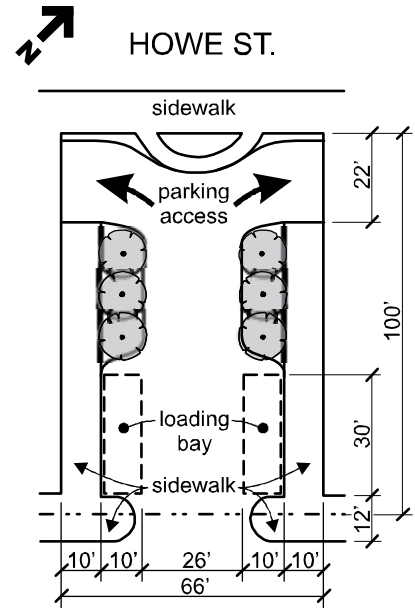

WEST ROLSTON  
**OFF-STREET ACCESS  
FOR PARCELS A & E**

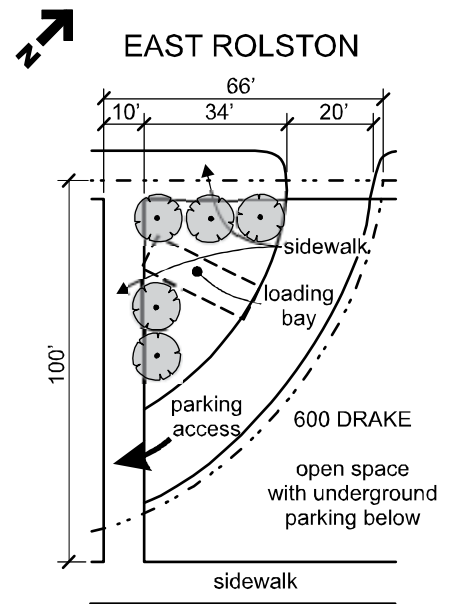

SEYMOUR ST.  
**OFF-STREET ACCESS  
FOR PARCEL D**





Possible Options for Bicycle Facilities





Possible Options for Bicycle Facilities



APPENDIX B: Minutes

and Report from January 20, 2009 Standing Committee on Transportation and Traffic

REPORT TO COUNCIL

STANDING COMMITTEE OF COUNCIL  
ON TRANSPORTATION AND TRAFFIC

JANUARY 20, 2009

A Regular Meeting of the Standing Committee of Council on Transportation and Traffic was held on Tuesday, January 20, 2009, at 9:50 a.m., in the Council Chamber, Third Floor, City Hall.

**PRESENT:** Councillor David Cadman, Chair  
Mayor Gregor Robertson  
Councillor Suzanne Anton  
Councillor George Chow, Vice-Chair  
Councillor Heather Deal  
Councillor Kerry Jang  
Councillor Raymond Louie  
Councillor Geoff Meggs  
Councillor Andrea Reimer  
Councillor Tim Stevenson  
Councillor Ellen Woodsworth

**CITY MANAGER'S OFFICE:** Penny Ballem, City Manager

**CITY CLERK'S OFFICE:** Nicole Ludwig, Meeting Coordinator

**ADOPTION OF MINUTES**

The Minutes of the Standing Committee on Transportation and Traffic meeting of October 28, 2008, were adopted, with Councillors Chow and Stevenson absent.

*Note from Meeting Coordinator: the two reports on this agenda were presented and speakers heard concurrently.*

**1. Granville Loops Policy Plan**

Staff from Planning and Engineering Departments presented the report and, along with staff from Real Estate Services, responded to questions.

The Committee heard from one delegation who noted concerns with the plan.

MOVED by Councillor Meggs  
THAT the Committee recommend to Council

THAT Council refer the policy report *Granville Loops Policy Plan* dated November 18, 2008, back to staff in order to consider and incorporate as much as possible the recommendations of the Bicycle Advisory Committee.

CARRIED  
(Councillor Anton opposed)

**2. Granville Loops: Interim Public Benefit Approach**

Staff from Planning and Engineering Departments presented the report and, along with staff from Real Estate Services, responded to questions.

The Committee heard from one delegation who noted concerns with the plan.

MOVED by Councillor Anton  
THAT the Committee recommend to Council

A. THAT Council approve the allocation of the \$7,000,000 Community Amenity Contribution from the 1304 Howe Street rezoning (approved July 8, 2008) as follows:

- \$6,000,000 for park acquisition and/or improvements; and
- \$1,000,000 for childcare purposes

in Downtown South or other nearby locations that can serve the future residents of the Granville Loops.

B. THAT with respect to the City-owned lands in the Granville Loops area, Council instruct staff to report back with public benefit recommendations in conjunction with future rezoning(s), taking into consideration the information contained in this report.

CARRIED UNANIMOUSLY

The Committee adjourned at 10:48 a.m.

\* \* \* \* \*



CITY OF VANCOUVER

**CITY OF VANCOUVER**  
**POLICY REPORT**  
**DEVELOPMENT AND BUILDING**

Report Date: November 18, 2008  
Contact: R. Johnson/  
T. French  
Phone No.: 604.873.7189/7041  
RTS No.: 07591  
VanRIMS No.: 08-2000-20  
Meeting Date: January 20, 2009

TO: Standing Committee on Transportation and Traffic

FROM: Director of Planning in consultation with the General Manager of Engineering Services, the Managing Director of Social Development, and the Director of Real Estate Services.

SUBJECT: Granville Loops Policy Plan

***RECOMMENDATION***

THAT Council adopt the Granville Loops Policy Plan (attached as Appendix A).

***GENERAL MANAGER'S COMMENTS***

The General Manager recommends approval of Recommendation A.

***COUNCIL POLICY***

*1975 Downtown Official Development Plan*

*2002 Downtown Transportation Plan*

***SUMMARY***

This report recommends approval of the Granville Loops Policy Plan in Appendix A to guide future development in the area of the north end of Granville Bridge. The impetus for the plan comes from the adopted Downtown Transportation Plan which directed staff to investigate the redesign of the bridge loops in order to improve access and pedestrianization in the area.

The overall vision is to reconfigure roadways, create accessible development parcels, improve connections, and upgrade a valuable area in terms of image and economic viability. This can be accomplished through guiding redevelopment by encouraging compatible land uses and designing the area to be cohesive both internally and with surrounding areas. The redevelopment of the area under the proposed policies could result in a form of development as illustrated in Figure 1.

Two significant sites (1304 Howe Street and 1300 Granville Street) have already rezoned in conformity with the evolving Plan. The remaining lands (approximately the south half of the area) are City owned. The Plan will guide a future Call for Expressions of Interest and Request for Proposals for the City properties over the next 5 - 15 years.

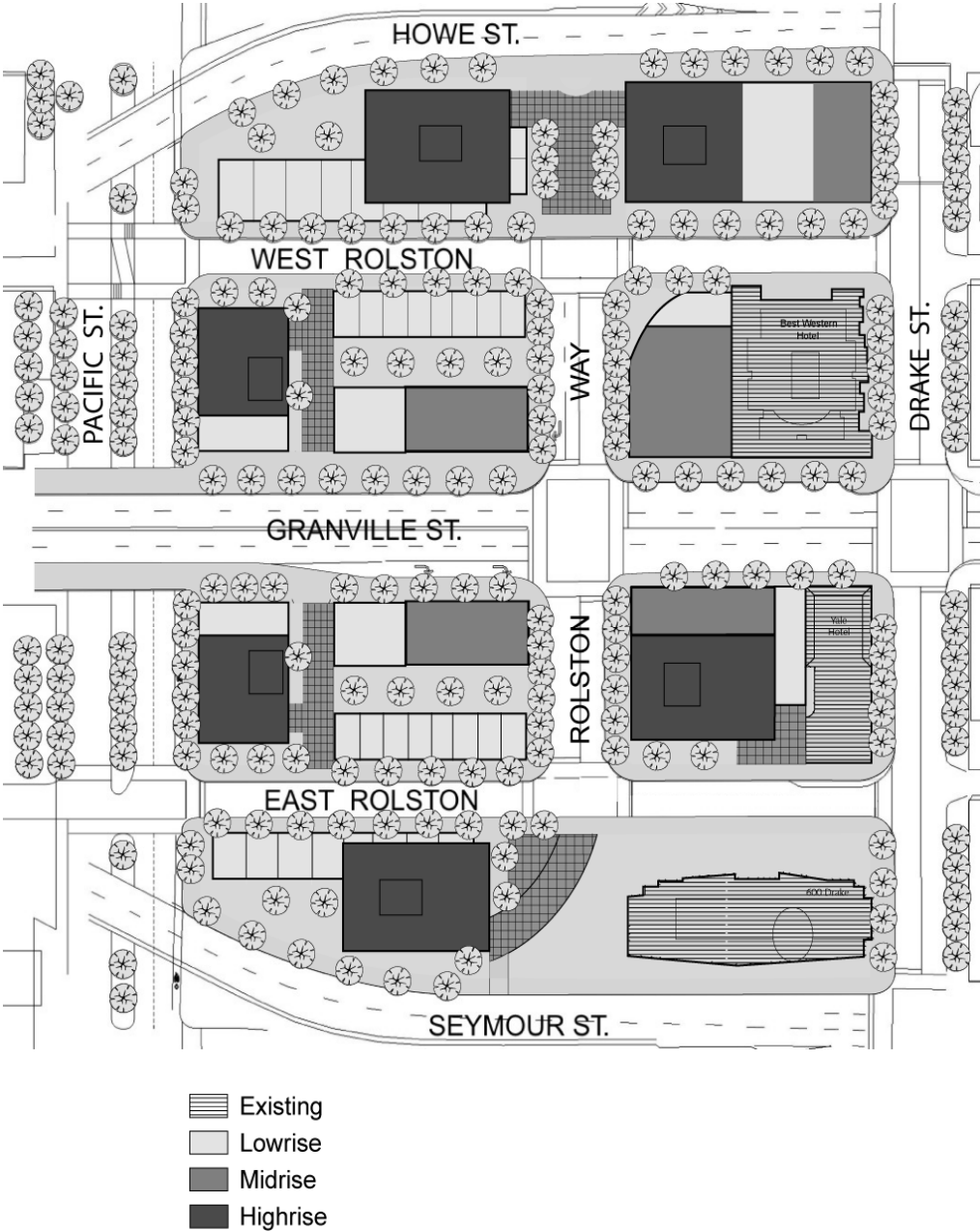

Overall, the Plan would accommodate construction of approximately 93,000 m<sup>2</sup> (1 million s.f.) of residential development and 4600 m<sup>2</sup> (50,000 s.f.) of commercial development. This would result in an overall area density of approximately 5.5 FSR and 114,000 m<sup>2</sup> (1.225 million s.f.) of floor space, similar to what can be built in the surrounding Downtown South area on a block by block basis.

**PURPOSE**

This report recommends Council approval of the Granville Loops Policy Plan (Appendix A) to guide future rezonings, development, and potential disposition and/or sale of City-owned lands in the area bounded by Drake, Seymour, Pacific, and Seymour streets.

**BACKGROUND**

The Downtown Transportation Plan (approved July 9, 2002) included a direction to change the street system at the north end of Granville Bridge in order to improve connections between downtown and False Creek and make better use of valuable land. Staff have evolved the Granville Loops Policy Plan through technical planning work, consultant study, and discussions with existing owners and tenants over the past few years.

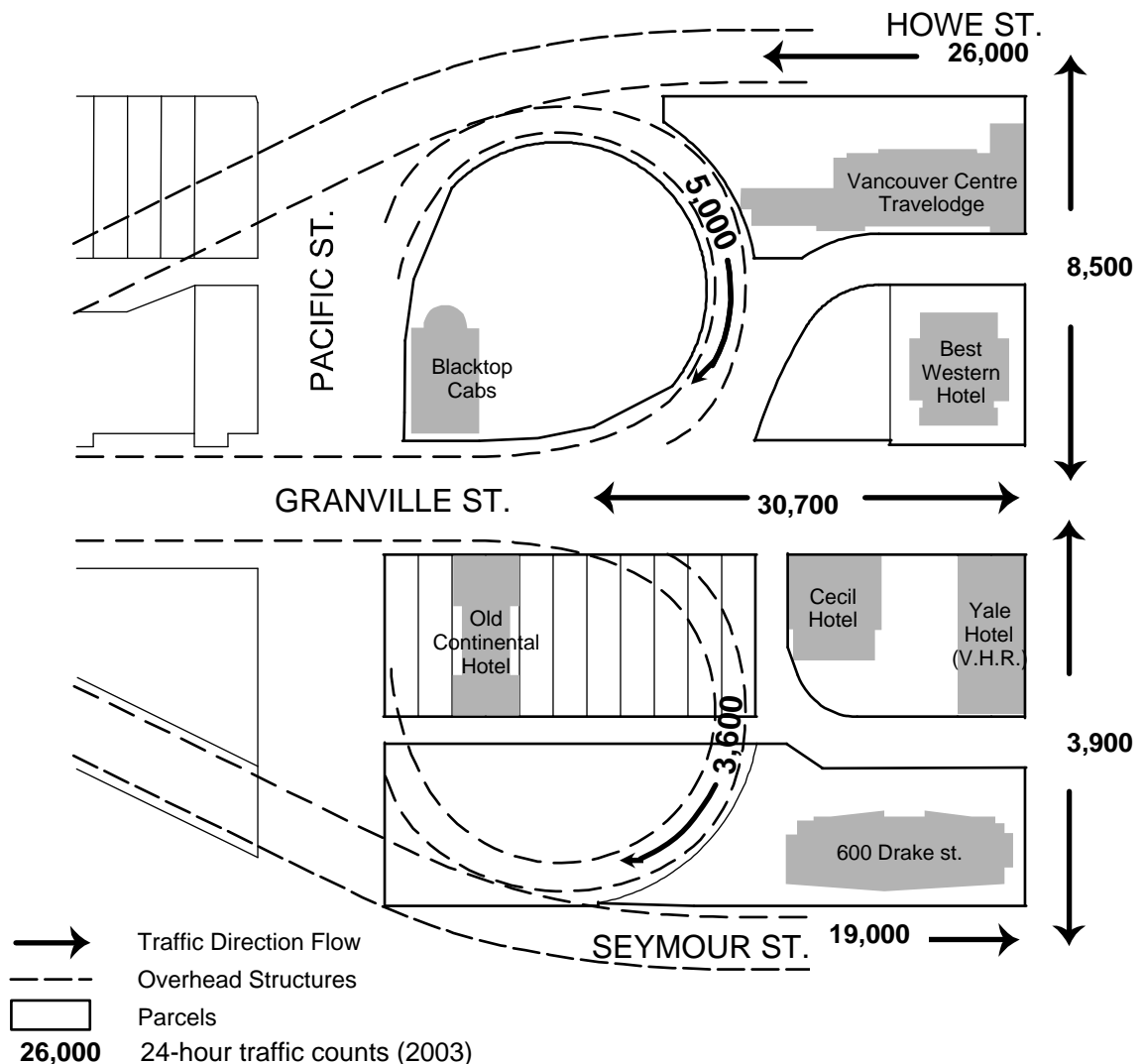

Fig. 2 Existing Conditions

The Plan area is bounded by Howe, Drake, Seymour, and Pacific streets. It is currently zoned area C of the Downtown Official Development Plan, which permits a range of commercial and residential uses with a maximum total 5 FSR (within which the maximum residential is 3 FSR). Maximum building height is 91.4m (300 ft.) with some additional height restrictions from the view cone on the east side of Granville Street. The existing conditions are generally illustrated by Figure 2.

The City owns the land within the physical confines of the bridge loops, which is currently occupied by the Old Continental Hotel (city-operated SRA), Blacktop Cabs (leased), and automobile storage (leased).

Two privately owned parcels are occupied by relatively recent development: the Best Western Hotel at Drake and Granville; and 600 Drake Street, a rental apartment building owned by the City and leased to Concert Properties.

Two other privately owned parcels were the subject of recent rezonings: 1304 Howe Street (former Travelodge site) and 1300 Granville Street (Yale and Cecil Hotel sites). These proposals were developed and reviewed while the Granville Loops Policy Plan evolved, and responded to its terms.

## *DISCUSSION*

### *1. Plan Overview*

The overall concept is illustrated in Figure 3.



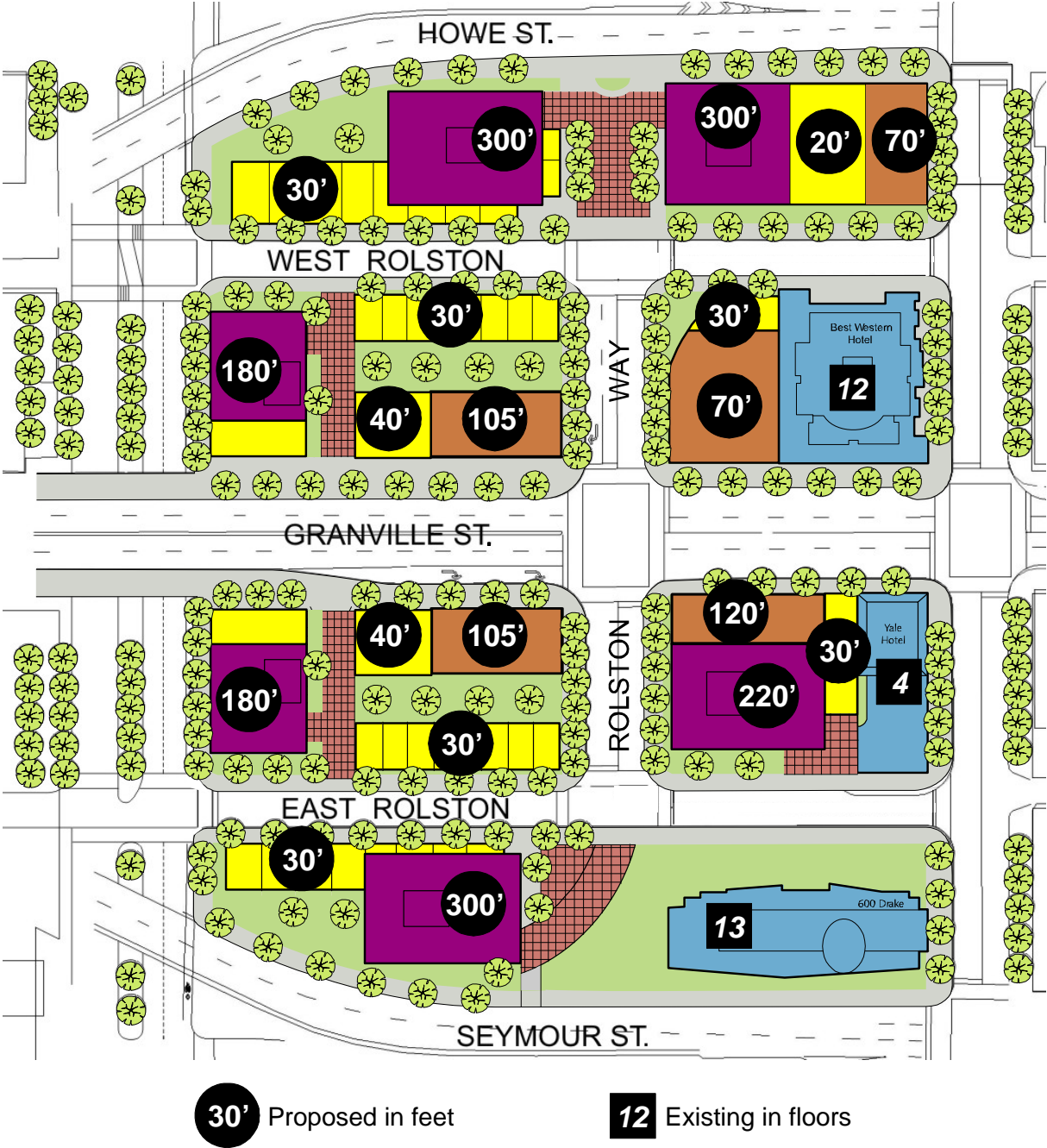

Fig. 3 Maximum Heights

The sections below provide highlights of how the Plan addresses transportation, land use and density, urban design, and environmental considerations.

a. Transportation

The Plan sees the freeway-like, elevated traffic loops at the north end of the Granville Bridge replaced by an H configuration of grade-level streets that connect with the surrounding streets and the bridge. The new streets proposed for the area have been unofficially named East Rolston, West Rolston, and Rolston Way. The existing circulation pattern of the loops would be maintained, which is important for access to several areas of downtown, however, the circulation will be accommodated in an urban context. East and West Rolston Streets will be narrower than typical streets, but are expected to accommodate anticipated vehicle volumes. Maintaining the existing circulation patterns, West Rolston would be a northbound one-way street and East Rolston would be a southbound one-way street. Rolston Way would be a two-way street, linking East and West Rolston streets across Granville Street, to allow better circulation within the neighbourhood.

Pedestrians will be able to walk down these townhouse-lined streets to False Creek, using improved pedestrian crossings of Pacific Street, including proposed crossings at East Rolston and West Rolston. Granville Bridge frontages will benefit from an improved streetscape, with larger sidewalks. New traffic signals would be installed at the intersection of Granville and Rolston Way, as well as at East Rolston and Pacific Street, to improve pedestrian and vehicular connections.

Existing traffic on the Loops is comparatively light when measured against most downtown streets. The combined traffic on the new street system has been reviewed and the new streets have been determined to have sufficient capacity for the redevelopment proposed for this area.

The new grade level streets provide much better pedestrian links not only to the development parcels within the Loops, but more importantly, between Granville Street, the Council approved 'Under the Granville Bridge' neighbourhood commercial area, and ultimately the False Creek shoreline/waterfront walkway.

The reconfiguration of the road network also allows the elimination of the merge lane under the Granville Bridge and the extension of the bike lanes westward to Howe Street.

b. Land Use and Density

The land uses in the Plan reflect those in Downtown South, emphasizing residential but allowing for compatible non-residential uses as well. Non-residential uses are required at grade along Granville, Drake, and Pacific to provide pedestrian interest and continue the character of the streets. Residential townhouses along the new Rolston streets provide a domestic feel. The Plan does not set out a maximum floor space or FSR, because the urban design and built form policies could result in a range. Instead, it describes an approximate achievable floorspace for each parcel, which will all be subject to further review during future rezonings. The amount of floor space in the

illustrated built form is about what occurs in an equivalent area in the adjacent Downtown South.

While non-residential is permitted, residential use is seen as the predominant use for a number of reasons. First, the area is too far from the commercial core of downtown to attract significant office development. Second, it is surrounded by predominantly residential neighbourhoods. Third, the smaller street widths on the 'new' streets lend themselves more to residential use than commercial use.

The Plan provides for the replacement of the non-market housing units in the Old Continental. The amount of floorspace in the proposed non-market building will be approximately double the floorspace of the existing Old Continental Hotel.

### c. Urban Design

The building massing creates a "valley gateway" with somewhat lower buildings on the Granville-fronting sites, flanked by higher towers on the Howe and Seymour edges of the area. This responds to the adopted planning direction for Granville Street further north, which is to ensure that the corridor retains its distinctive mid-rise scale. The paired taller towers are a maximum of 91.4m (300 ft.) high, similar to the adjacent maximum in Downtown South (See Figure 4).



Fig. 4 Granville Loops  
Gateway from Granville

Given the size and location of nearby towers, these two buildings will be quite prominent in marking the entry to downtown. However, if the current Downtown Capacity Options Study re-examines heights in the nearby areas, there may be the possibility of considering additional height (and resulting density) on these two sites.

Policies in the Plan address the full range of urban design issues including heights, tower floorplates, streetwall heights, setbacks, streetscape character, views, livability, handling of parking and access, and relationship to the public realm.

#### d. Environmental Requirements

The Plan contains policies tying the future development to any 'green' building policies in place at the time of development, and noting the need to respond to soils remediation policies, as well as solid waste and recycling policies.

## 2. Plan Implementation

This section discusses the economics and possible timing of Plan implementation.

### a. Economics

Detailed economic pro forma analysis has been undertaken by staff on the City-owned sites. It indicates that the project can carry the costs below, return the current land value to the Property Endowment Fund, and have funds remaining for other public benefits(see section 3).

The redevelopment of the City-owned lands needs to provide for removal of the bridge loops, the remediation of soils, the reconstruction of the street system, the replacement of the City-owned Old Continental Hotel, any costs associated with the possible relocation of existing tenants, and payment for the rebuilding of utilities with the assistance of private redevelopments on a pro-rata share basis.

### b. Phasing

The redevelopment of the City-owned lands may well require a phased approach reflecting project size, market conditions, and existing tenancies. As Black Top Cabs has a ground lease expiring in 2022, the phased approach will be more likely, unless Black Top chooses to relocate prior to the end of their lease. A phasing plan has been produced (as illustrated by Figure 5) which indicates possible options for a phased approach. Option A maintains the existing access from the east, while Option B provides an access point from the west loop.

Option A

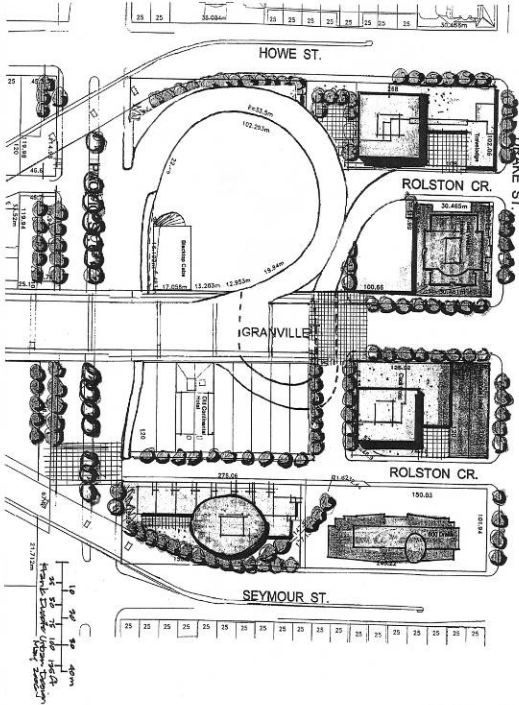

Option B

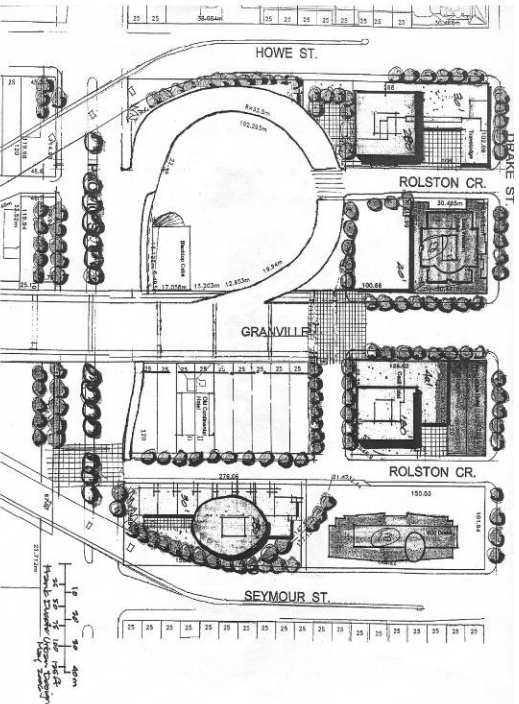

Fig. 5 Phasing Options

### 3. Public Benefits

Certain public benefits are inherent in the Plan proposal. A high quality streetscape will be provided along the new streets of East Rolston, West Rolston, and Rolston Way. In addition, Pacific and Granville streets will be renovated where possible to extend the public realm on the ground level, as well as to provide extensions to the bridge deck.

The replacement of the Old Continental Hotel is also assumed as part of the Plan. A site has been provided on the west side of Granville which will allow for all of the units to be rebuilt in a building with significantly larger unit sizes and a full ground floor level of service and amenities.

The provision of additional public benefits will be feasible through the use of development cost levies and community amenity contributions from the two recent private rezonings, and from the eventual rezoning of the City-owned lands. This is the topic of discussion of the companion report on the Granville Loops Public Benefit Strategy.

#### **PUBLIC CONSULTATION**

A series of meetings have taken place with area landowners, area leaseholders, special interest groups, city committees, and the public. In general, very few issues have arisen and there is strong support for the plan.

A public open house attracted over 200 people and questionnaires were filled out by approximately 50 attendees. The results are that on average 70% support the plan, with 15% neutral, and 15% opposed. Of the individuals opposed, the main concerns were: loss of private views that are now enjoyed due to minimal existing buildings in the Loops; the area not being permanently dedicated to public open space; and increased traffic in the area. The proposed plan is based on overall goals of improving public access through the area and creating an improved gateway to the city by developing the land through policies that are comparable with existing zoning and surrounding uses.

The Vancouver City Planning Commission had high praise for the Plan and felt that it was a well thought out land use plan which would complement the surrounding areas. The Urban Design Panel felt that the overall design was very supportable and produces a good architectural statement and welcoming entry to the City. They also felt innovative green building opportunities should be explored at the time of redevelopment. Staff note the Plan calls for green building strategies to be implemented which are in force at the time of rezoning. It is uncertain as to timing and phasing of the total project, so a specific strategy would be premature to put in place at this time, but could be considered in the future.

The Bicycle Advisory Committee reviewed the proposed plan and wanted more emphasis on cycling facilities through restricting the access of automobiles to the new streets and providing separated bike lanes on the existing streets. Alternatively, the BAC requested Council to consider separated bike facilities on the new streets. Staff note that the cycling plan in the Downtown Transportation Plan will be adhered to,

providing cycling lanes on Pacific Street. New streets designed as a result of this plan will be designed as bike friendly streets and will be similar in nature to other 'Bike friendly' streets identified in the Downtown Transportation Plan.

***FINANCIAL IMPLICATIONS***

There will be no financial implications for the City. Current analysis indicates there will be surplus funds available for public benefits.

***ENVIRONMENTAL IMPLICATIONS***

The redevelopment of the area will increase population above current projections in a location that is well served by transit, job opportunities, services, and recreation. This will in turn help encourage non-vehicular or transit related modes of travel. Bike parking will be provided in all buildings to City standards to further these goals.

The development will be regulated by by-laws and regulations that implement the City's Green Building Strategy. Provincial regulations in regard to soil quality will apply to all redevelopment.

***SOCIAL IMPLICATIONS***

The existing City-owned SRO, the Old Continental Hotel, will be redeveloped on the west side of Granville Street providing new accommodation, with the potential for much larger units. It may also be possible to build more units at a slightly smaller size to offset potential loss of units elsewhere, while still maintaining a larger unit size than currently exists. The City will ensure that tenants are relocated in a manner which creates the least disruption in the shortest time period possible, and that tenants will be offered the opportunity to relocate into the new building when possible.

***CONCLUSION***

The Granville Loops Policy Plan provides a detailed blueprint of how to move forward with a key approved direction from the 2002 Downtown Transportation Plan. The result will be much-improved linkages between downtown and False Creek, as well as allowing for appropriate redevelopment of City-owned lands.

\* \* \* \* \*





VanRIMS No.: 08-3000-11

## MEMORANDUM

September 16, 2010

TO: Richard Johnson, Planning Department  
FROM: Nicole Ludwig, Meeting Coordinator  
CC: David Lewis, Bicycle Program Coordinator  
SUBJECT: Bicycle Advisory Committee Motion Re: Granville Loops

---

At the Bicycle Advisory Committee meeting on September 15, 2010, it was

MOVED by Kari Hewett  
SECONDED by Rhiannon Chernencoff

THAT the Bicycle Advisory Committee generally support the plan for Granville Loops as presented at the September 15, 2010, meeting, noting the following:

- commitment to a range of high-quality facilities, and
- preference to high-quality separated facilities.

CARRIED UNANIMOUSLY

*tel:* 604..  
*fax:* 604..

<none>