



ADMINISTRATIVE REPORT

Report Date: 2009-04-24  
Contact: David Ramslie  
Contact No.: 604.873.7946  
RTS No.: 07199  
VanRIMS No.: 08-2000-20  
Meeting Date: May 7, 2009

TO: Standing Committee on City Services and Budgets  
FROM: The Director of Planning and the Manager of the Sustainability Group  
SUBJECT: Passive Design Tool Kit

**RECOMMENDATION**

- A. THAT Council endorse the “Passive Design Tool Kit” and the “Passive Design Tool Kit for Homes” as official City of Vancouver publications.
- B. THAT Council direct staff to develop and deliver a passive design engagement program to build capacity and awareness for both City staff and the development industry on the benefits of passive design.
- C. THAT Council direct staff to bring forward new or amended land use policy on an ongoing basis with the goal of promoting and implementing passive design strategies and approaches in the City of Vancouver.

**CITY MANAGER'S COMMENTS**

The City Manager recommends approval of the recommendations in this report.

## ***COUNCIL POLICY***

In March 2005, Council approved the Community Climate Change Action Plan to reduce greenhouse gas (GHG) emissions in the community to 6% below 1990 levels by 2012.

In March 2007, Council passed a motion directing staff to begin planning for significant, long range GHG reductions with the eventual goal of becoming a carbon-neutral city.

In May 2007, Council adopted the Building By-law (VBBL) which included environmental protection objectives. Although no new “green building” requirements were added to the by-law at that time, the environmental protection objectives were put into place to facilitate the future development of the City’s Green Building Strategy.

In July 2007, Council adopted targets to reduce community GHG emissions to 33% below current levels by 2020 and 80% below current levels by 2050. In addition, Council adopted the target of having all new construction in Vancouver be GHG neutral by 2030.

In November 2008, Council passed a motion to remove 5 barriers to green building approaches and directed staff to report back when other barriers were identified and removed.

## ***PURPOSE***

The purpose of this report is to promote the adoption of passive design strategies in building design and construction in Vancouver with the goal of improving energy efficiency, and occupant comfort in order to reduce GHG emissions in Vancouver.

## ***SUMMARY***

Passive Design is a proven concept for improving energy efficiency that, to date, has not been widely employed by municipalities to reduce GHGs. Should Council accept the recommendations in this report it would be the first jurisdiction in North America to actively pursue a program that addresses the architecture of buildings to reduce GHGs beyond the application of green building codes. The staff recommendation accomplishes this in two ways: (1) through outreach and capacity building; and (2) through ongoing policy development and amendment. The Passive Design Tool Kits form the core content of the strategy and are appended to this report. (Appendix A & B are limited distribution and linked from the May 7, 2009 CS&B agenda at [http://vancouver.ca/ctyclerk/councilmeetings/meeting\\_schedule.cfm](http://vancouver.ca/ctyclerk/councilmeetings/meeting_schedule.cfm).)

## ***BACKGROUND***

In 2007 Council approved a work plan for staff to begin policy research and recommend by-law amendments to achieve “greener” buildings. The promotion of passive design through building policy was specifically identified in this report as a strategy for further exploration. Council has also adopted a series of ambitious targets for greenhouse gas (GHG) reductions including targets to reduce community GHG emissions by 33% below current levels by 2020 and 80% below current levels by 2050 to reflect and support adopted provincial targets. With regard to buildings in Vancouver, Council adopted the target of having all new construction in Vancouver GHG neutral by 2030.

## **DISCUSSION**

The two Passive Design Tool Kits detail a number of strategies for achieving energy efficiency and improved thermal comfort through building design. The guides detail the strategies and evaluate each design element in terms of its relative cost and effectiveness. The two Tool Kits are:

- 1) The ‘Vancouver Passive Design Tool Kit’ focuses primarily on what the VBBL classifies as Part 3 buildings, encompassing a wide range of project types from high rise residential, to commercial and mixed-use buildings. This guide is based on computer generated building energy models calibrated to Vancouver building typologies and local climate to support claims about the benefits of each design strategy.
- 2) The ‘Vancouver Passive Design Tool Kit for Homes’ is directed at wholly residential Part 9 wood frame buildings as defined by the VBBL, the majority of which are one- and two-family dwellings. This document is more prescriptive than the Part 3 guide, reflecting the prescriptive nature of Part 9 of the VBBL. This Tool Kit is based on the extensive research of the Passiv Haus Institute and adapted to the Vancouver local climate and building market.

Both Tool Kits were written with the following goals:

- To raise the collective level of knowledge of staff and the Development and Design community regarding the energy efficiency and thermal comfort benefits of passive design.
- To Outline best practices and define how passive design can be applied in Vancouver’s climate to maximize energy savings and occupant comfort.
- To establish a commonly understood definition of passive design across the industry in Vancouver.

Passive design is the most effective tool for achieving energy efficiency and optimizing thermal comfort in buildings. The Passive Design Tool Kits define passive design as, “an approach to design that discourages reliance on mechanical systems for heating, cooling and lighting by harnessing naturally occurring phenomena such as the power of the sun and wind patterns to maintain consistent indoor temperatures, comfortable thermal environments, and interior illumination”. (Appendix A&B) Passive design in the Vancouver context works on the premise that, if applied successfully, the need for mechanical intervention for thermal comfort reasons can be eliminated entirely in some applications.

Passive design strategies covered in the Tool Kits include passive heating using the sun’s energy, solar rejection to prevent excessive heat gain, using the sun to day-light interior spaces, and developing natural ventilation systems through building form. Elements of these strategies include modifications to the building envelope, the placement and quality of glazing, the form and shape of the building and interior spaces, and as the choice of building materials.

The strategies detailed in the Tool Kits engage designers and regulators to consider energy reduction and human thermal comfort as primary goals at the outset of the design of any building. The incorporation of passive design strategies into new building projects in Vancouver will help projects to meet and surpass the required energy utilization standards in the VBBL. Reducing energy loads through architectural design will also allow buildings in

Vancouver to move toward the goal of achieving carbon neutrality in all new development by 2030 and will be supportive of helping to make Vancouver the greenest city in the world.

The first recommendation of this report is for Council to endorse the Passive Design Tool Kits as a means of reducing GHGs in the City of Vancouver. This recommendation is critical to capacity building and future policy development and implementation; by establishing an agreed-upon official definition and principles of passive design for Vancouver, the Tool Kits will serve as a basis for constructive policy discussion and can be used as a tool to reorient building design toward a new baseline of energy efficiency and thermal comfort.

The second recommendation of this report directs staff to engage with the development and design communities to disseminate the content of the Tool Kits. Staff propose two strategies to accomplish this, the first is to develop a strategy to engage with stakeholders directly through a targeted outreach program focussed on designers and developers. This will be supported by conventional communication tools such as staff presentations, the City website and printed media. The second strategy will be to engage stakeholders directly through points of contact where City staff are engaged by the development community via the pre-application and development permit process.

The third recommendation in this report directs staff to examine current policy, and to bring forward recommendations, where appropriate, to integrate passive design as defined by the Toolkits. This will be done by bringing forward new policy, or amending existing guidelines. Within this policy review, staff will make recommendations, where appropriate, that remove policy barriers to the inclusion of passive design elements. An economical approach will be used to ensure that this program does not add additional complexity and time to the permit process. This recommendation will empower staff to make better informed decisions with regards to passive design where discretion is applied in the approvals process.

Staff recognize that some of the recommended design elements, specifically those concerned with glazing, may challenge the current practice recommended by the Vancouver real-estate marketing community. Staff will engage with the marketing, development, and design communities as part of the policy development process to address these issues and others as policy is amended or developed for passive design.

### ***STAKEHOLDER CONSULTATION***

The guides were developed by the Sustainability Group in conjunction with a consultant team of local Architects, Green Building Design specialists, and Engineers. The guides were in turn reviewed internally by an interdepartmental team specialising in land-use policy, design, and the development approvals process. It was reviewed externally by the Association of Professional Engineers and Geoscientists of BC (APEG) and the Architectural Institute of BC (AIBC) and the City of Vancouver Urban Design Panel all of whom supported the development and content of the Tool Kits and requested to remain engaged with the continuing evolution of the documents and associated policy.

***FINANCIAL IMPLICATIONS***None. City staff partnered with BC Hydro in the development of both guides in order to reduce costs. Staff will continue to leverage external partner funding to share or offset the costs of the printing and program delivery in order to deliver it to as broad a stakeholder audience as possible.

### ***ENVIRONMENTAL IMPLICATIONS***



The Passive Design Tool Kits outline an approach to building design where the reduction of environmental impact is the primary objective. The energy consumption associated with mechanical heating, cooling, ventilation and electrical lighting in buildings is responsible for approximately 54% of all GHG generated in the City. To date, Vancouver's response to dealing with these issues has been to improve the energy utilisation sections of the VBBL. While addressing building envelope issues and mechanical and electrical systems, the VBBL does not address the overall architecture of buildings. This leaves a significant opportunity to reduce energy consumption, and therefore GHG's. If applied aggressively, energy savings through passive design strategies can reduce the GHG emissions associated with new buildings in Vancouver by as much as 80%.

### ***COMMUNICATIONS PLAN***

The public consultation process that was implemented in the development of the Tool Kits will be continued once they are made public. There are two objectives of the communications plan:

- (1) to broadly disseminate the recommendations included in the guides through constructive engagement with the development and design industry city-wide as outlined in the body of the report.
- (2) to use the guides to form the basis of a policy development discussion with industry stakeholders by means of consultation with professional committees, associations and other interest groups.

### ***CONCLUSION***

Passive Design is a proven concept that has thus far been under-utilized by municipalities as a tool to reduce GHGs. In promoting passive design through education, and policy, the City will not only move closer to achieving its GHG reduction targets but will also help to make Vancouver the greenest city in the world.

\* \* \* \* \*

## Passive Design Tool Kit

# □ Passive Design Toolkit

BEST PRACTICES



**City of Vancouver**  
**Passive Design Toolkit - Best Practices**  
November 2008

**Prepared by:**

**Cobalt Engineering**

Vladimir Mikler, MSc, P.Eng., LEED® AP

Albert Bicol, P.Eng., LEED® AP

Beth Breisnes

**Hughes Condon Marler : Architects**

Michel Labrie, MAIBC, MOAQ, MRAIC, LEED® AP

# Contents

<b>1. Executive Summary</b> .....	<b>1</b>
1.1 Purpose.....	1
1.2 Navigating this Toolkit .....	1
1.3 Summary of Recommendations .....	1
<b>2 Context</b> .....	<b>3</b>
2.1 Definition of Passive Design.....	3
2.2 Thermal Comfort .....	3
2.3 Vancouver Climate Characteristics .....	6
2.4 Energy Performance Targets.....	7
2.5 Integrated Design Process .....	8
<b>3 Passive Design Strategies</b> .....	<b>9</b>
3.1 Passive Heating.....	10
3.2 Passive Ventilation .....	10
3.3 Passive Cooling .....	11
3.4 Daylighting .....	12
3.5 Applying the Strategies: Residential.....	13
3.6 Applying the Strategies: Commercial .....	14
3.7 Modeling Summary.....	15
<b>4 Passive Design Elements</b> .....	<b>17</b>
4.1 Site and Orientation.....	17
4.2 Building Shape and Massing .....	19
4.3 Landscape Considerations .....	21
4.4 Space Planning .....	23
4.5 Buffer Spaces.....	24
4.6 Windows.....	27
4.7 Solar Shading.....	30
4.8 Thermal Mass .....	32
4.9 Thermal Insulation.....	34
4.10 Air and Moisture Tightness.....	35
<b>Appendix A – Glossary of Key Terms</b> .....	<b>39</b>
<b>Appendix B – Thermal Comfort</b> .....	<b>41</b>
B.1 Parameters.....	41
B.2 Fanger Model .....	41
B.3 Adaptive Model .....	42
B.4 Free Run Temperature .....	44

# Contents

<b>1. Executive Summary</b> .....	<b>1</b>
1.1 Purpose.....	1
1.2 Navigating this Toolkit .....	1
1.3 Summary of Recommendations .....	1
<b>2 Context</b> .....	<b>3</b>
2.1 Definition of Passive Design.....	3
2.2 Thermal Comfort .....	3
2.3 Vancouver Climate Characteristics .....	6
2.4 Energy Performance Targets.....	7
2.5 Integrated Design Process .....	8
<b>3 Passive Design Strategies</b> .....	<b>9</b>
3.1 Passive Heating.....	10
3.2 Passive Ventilation .....	10
3.3 Passive Cooling .....	11
3.4 Daylighting .....	12
3.5 Applying the Strategies: Residential.....	13
3.6 Applying the Strategies: Commercial .....	14
3.7 Modeling Summary.....	15
<b>4 Passive Design Elements</b> .....	<b>17</b>
4.1 Site and Orientation.....	17
4.2 Building Shape and Massing .....	19
4.3 Landscape Considerations .....	21
4.4 Space Planning .....	23
4.5 Buffer Spaces.....	24
4.6 Windows.....	27
4.7 Solar Shading.....	30
4.8 Thermal Mass .....	32
4.9 Thermal Insulation.....	34
4.10 Air and Moisture Tightness.....	35
<b>Appendix A – Glossary of Key Terms</b> .....	<b>39</b>
<b>Appendix B – Thermal Comfort</b> .....	<b>41</b>
B.1 Parameters.....	41
B.2 Fanger Model .....	41
B.3 Adaptive Model .....	42
B.4 Free Run Temperature .....	44

## Contents Continued...

### Appendix C – Vancouver Climate Characteristics ..... 45

C.1 Overview .....	45
C.2 Air Temperature and Humidity .....	45
C.3 Solar Radiation .....	49
C.4 Wind.....	50
C.5 Precipitation.....	51
C.6 Outdoor Design Temperatures .....	51

### Appendix D – Energy Performance Targets..... 53

### Appendix E – Energy Modeling..... 55

E.1 Introduction.....	55
E.2 Study Cases .....	55
E.3 Baseline Model .....	57
E.4 Orientation.....	58
E.5 Balcony Buffer Space.....	60
E.6 Window to Wall Area Ratio.....	63
E.7 Window Performance .....	66
E.8 Solar Shading .....	70
E.9 Thermal Mass .....	74
E.10 Wall Insulation .....	77
E.11 Infiltration.....	80
E.12 Heat Recovery Ventilation.....	82
E.13 Natural Ventilation.....	85
E.14 Strategy: Passive Heating .....	89
E.15 Strategy: Passive Cooling .....	92
E.16 Strategy: Residential Approach.....	94
E.17 Strategy: Commercial Approach.....	97
E.18 Commercial Schedule .....	99

### Appendix F – Case Studies .....101

O <sup>2</sup> .....	101
Millenium Water – Vancouver’s Olympic Athlete’s Village .....	102
Pacific Institute for Sport Excellence, Camosun College .....	103
Liu Institute for Global Issues, UBC .....	104
Revenue Canada Offices .....	105
City of White Rock Operations Centre.....	106
Dockside Green .....	107
Butchart Gardens Carousel Building .....	108
Hillcrest Community Centre .....	109



# 1. Executive Summary

## 1.1 Purpose

This document presents best practices for the application of passive design in Vancouver. It is intended to establish a common vision and definition of passive design and support decision making for new developments<sup>1</sup> that will maximize occupant health and comfort and minimize energy use by relying less on mechanical and electrical systems. Furthermore, it is intended to move the Vancouver design community toward a new, higher standard of energy efficiency without sacrificing thermal comfort.

This document is not prescriptive, but rather discusses and analyzes recommended design approaches and the energy saving opportunities each presents. Additionally, the modeling results shown are useful and valid but do not replace the value of project-specific modeling.

## 1.2 Navigating this Toolkit

This toolkit is organized into three main sections:

1. Context
2. Passive Design Strategies
3. Passive Design Elements

Context provides the fundamental frameworks for understanding and implementing passive design. Passive Design Strategies lays out the overarching strategies that will optimize comfort and

minimize energy requirements on new developments in Vancouver. Each strategy is made up of several design elements. Each element is addressed in further detail in Passive Design Elements.

Finally, the appendices provide supporting information, including detailed energy modeling analysis.

## 1.3 Summary of Recommendations

When building in Vancouver, it is recommended that designers adopt a passive design approach that uses the building architecture to maximize occupant comfort and minimize energy use. Design teams that understand the basic concepts and implement the strategies recommended in this toolkit will optimize passive performance and achieve the many spin-off benefits of energy efficient, thermally comfortable buildings. Of course, the application of passive design must be carefully considered within the specific constraints and opportunities of each project.

The key passive design recommendations for buildings in Vancouver are summarized below. (See Appendix E for energy modeling to support all statements.)

- Design each facade specific to its orientation.
- Where possible, minimize east and west exposures to avoid

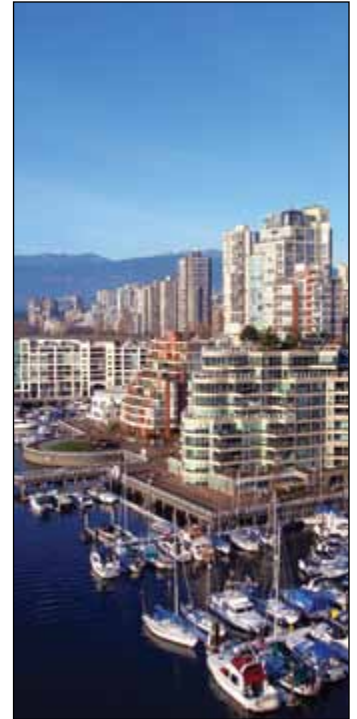

□ When building in Vancouver, it is recommended that designers adopt a passive design approach that uses the building architecture to maximize occupant comfort and minimize energy use.

<sup>1</sup> This toolkit is intended for Part 3 buildings, as per the National Building Code of Canada (2005).





## □ Design for cooling by natural ventilation.

unwanted solar gains.

- For better energy performance, attempt to limit windows to 50% on any facade (for best performance, limit windows to 30%), taking into account other aesthetic and livability criteria. If higher window to wall area ratios are desired, incorporate high performance windows or a double facade and optimize shading.
- Target overall wall assembly RSI values between 2.3 (ASHRAE minimum) and 2.9. Use modeling to assess project-specific benefits, as the impact of insulation depends greatly on window to wall area ratio.
- Use an air-tight envelope to minimize uncontrolled infiltration.
- Use heat-recovery ventilation during heating season only, and design for natural ventilation and cooling by natural ventilation throughout the rest of the year.
- For residential buildings, use clear glass with good insulating value (low U-value with low-e coating). Mitigate unwanted solar gains with external shading and allow for passive cooling by natural ventilation.
- For commercial buildings, use either clear glass with effective external shading elements or dark or reflective glass (low shading coefficient) to control unwanted solar gains. Regardless of shading option, the glass should have good insulating value (low U-value with low-e coating). Remove internal heat gains with other passive elements (e.g., natural ventilation).
- Incorporate overhangs providing shading angles of 20°-30° off vertical (measured from the bottom window sill to the edge of the overhang) on south-facing windows.
- Incorporate operable external shading on east-, south- and west-facing windows.
- Use thermal mass that is exposed to the conditioned space and combine it with other passive elements to achieve its full energy-savings and comfort potential.
- Incorporate buffer spaces on all exposures whenever possible to optimize comfort and reduce both peak load and overall heating and cooling energy requirements.
- Design for cooling by natural ventilation in all building types.
- Optimize the effects of passive heating and cooling strategies by strategically combining passive elements.
- Incorporate as many passive design elements as possible to optimize comfort and minimize overall energy use.

## 2 Context

### 2.1 Definition of Passive Design

“Passive design”<sup>2</sup> is an approach to building design that uses the building architecture to minimize energy consumption and improve thermal comfort. The building form and thermal performance of building elements (including architectural, structural, envelope and passive mechanical) are carefully considered and optimized for interaction with the local microclimate. The ultimate vision of passive design is to fully eliminate requirements for active mechanical systems (and associated fossil fuel-based energy consumption) and to maintain occupant comfort at all times.

Even though we may not achieve the ultimate passive design vision on every building, implementing the passive design approach to the fullest extent possible will lower building energy use. Building shape, orientation and composition can improve occupant comfort by harnessing desirable site-specific energy forms and offering protection from undesirable forms of energy. Through properly applied passive design principles, we can greatly reduce building energy requirements before we even consider mechanical systems.

Designs that do not consider passive thermal behaviour must rely on extensive and costly mechanical HVAC systems to maintain adequate

indoor conditions, which may or may not even be comfortable. Furthermore, even the most efficient technologies will use more energy than is necessary with a poorly designed building.

To successfully implement the passive design approach, one must first accomplish the following:

1. Understand and define acceptable thermal comfort criteria.
2. Understand and analyze the local climate, preferably with site-specific data.
3. Understand and establish clear, realistic and measurable energy performance targets.

### 2.2 Thermal Comfort

Proper understanding of the parameters around thermal comfort is a critical component of successful building and system design. It is especially important in passive design, where buildings must maintain thermal comfort without the aid of active mechanical systems for as much of the year as possible.

Thermal comfort refers specifically to our thermal perception of our surroundings. The topic of thermal comfort is a highly subjective and complex area of study. Through passive design, we can impact four indoor environmental factors that affect thermal comfort:

□ “Passive design” is an approach to building design that uses the building architecture to minimize energy consumption and improve thermal comfort.

<sup>2</sup> Also known as “climate adapted design” or “climate responsive design”

- Air temperature
- Air humidity
- Air velocity
- Surface temperatures

Each factor affects thermal comfort differently. The factors most commonly addressed in the conventional design process, air temperature and air humidity, in fact affect only 6% and 18% of our perception of thermal comfort, respectively. To take a more effective comfort-focused approach, we must also consider the temperature of surrounding surfaces and the air velocity, which account for 50% and 26% of thermal comfort perception, respectively.

The effectiveness of passive strategies depends on the range of acceptable thermal comfort parameters set for the project.

### 2.2.1 Thermal Comfort Models

As human thermal comfort perception is extremely complex and subjective, defining acceptable comfort parameters is particularly challenging. Despite these difficulties, several models for quantitatively measuring occupant comfort have been widely used. The two most relevant in this case are the Fanger and Adaptive Models.

The Fanger Model is most commonly used for typical buildings that rely solely on active mechanical systems. It defines comfort in terms of air temperature and humidity because these parameters are easy to measure and control. It prescribes a relatively narrow range of acceptable levels which, in common practice, do not vary with outdoor conditions on a daily or yearly basis.



*Thermal comfort is a very subjective term thus making it difficult to model.*

**Figure 1: Key thermal comfort parameters**

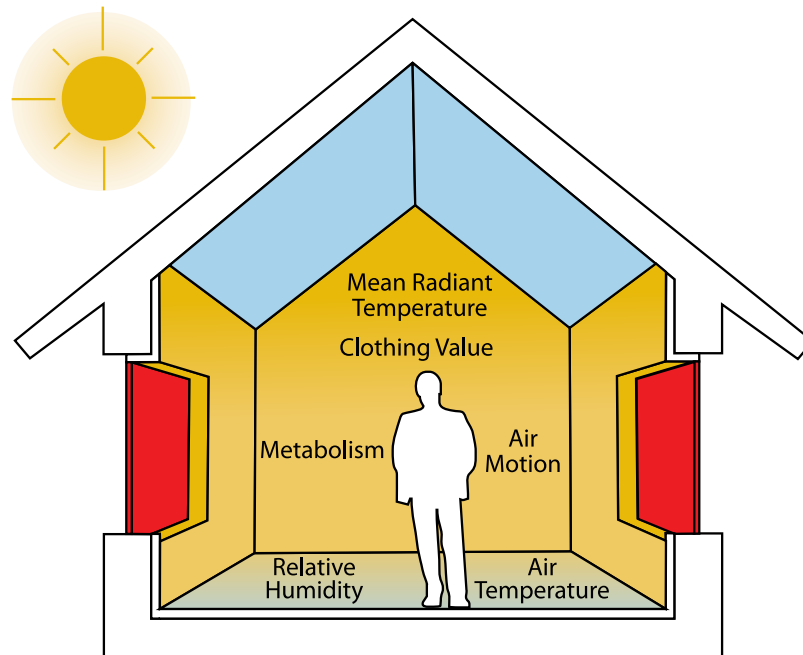

This suits the conventional approach which has heavy reliance on active mechanical systems regardless of the outdoor climatic conditions. But this can also lead to unnecessary energy consumption. Furthermore, this simplification does not account for the temperature of surrounding surfaces, the dominant factor affecting thermal comfort.

The complexity of human thermal comfort, particularly in passively designed buildings, can be better described by the lesser-known Adaptive Model.

The Adaptive Model correlates variable outdoor conditions with indoor conditions and defines comfort with a wider range of thermal parameters, making it more suited to buildings with passive features and natural ventilation. In the mild Vancouver climate, passive buildings can maintain acceptable thermal comfort within the parameters of the Adaptive Model for the majority of the year, with the exception of the coldest outdoor temperatures during winter.

Using the passive design approach and the Adaptive Model can significantly reduce a building's reliance on energy-intensive active mechanical systems.

The required strategies to achieve such passive performance are discussed in Section 3 of this toolkit. See Appendix B - Thermal Comfort for further details on both thermal comfort models.

### 2.2.2 Resultant Temperature

Resultant temperature<sup>3</sup> is the average of the air temperature and temperature of the surrounding surfaces (i.e., Mean Radiant Temperature or MRT). Surface temperatures affect occupant comfort by radiant heat transfer, the most dominant factor of human comfort perception, and air temperature affects comfort by convection and conduction, less dominant factors.

As long as the resultant temperature of the space remains within the targeted comfort range, occupants will feel comfortable, even as the air temperature fluctuates outside the comfort range. Conversely, when the resultant temperature of the space is outside the defined comfort range because of a cold or hot surface (e.g., a hot window on a sunny day), occupants will feel uncomfortable even if the desired air temperature set point is maintained.

The resultant temperature and MRT can be controlled by passive design strategies, which are discussed in Section 3 of this toolkit.

### 2.2.3 Free Run Temperature

Free Run Temperature (FRT) represents the natural temperature variation inside a building operating in an entirely passive mode, that is, without the involvement of active mechanical systems. An annual FRT

3 Also known as operative temperature;  $RT = (Average\ Air\ Temp + Mean\ Radiant\ Temp)/2$



□ Understanding the local climate is the foundation of passive design.

profile is a very effective tool for understanding a building’s passive response to its local climate. Once generated with building simulation software, an FRT profile can be used to test passive strategies. Effective passive strategies keep the FRT within the comfort range (or close to it) for most of the year. Optimizing the FRT minimizes the amount of energy required of the mechanical system.

*See Appendix B.4 - Free Run Temperature for further details.*

### 2.3 Vancouver Climate Characteristics

Understanding the local climate is the foundation of passive design. It guides the selection of appropriate passive design strategies and affects the extent to which mechanical systems are needed to maintain comfort.

Vancouver (49.18° N, 123.17° W) is located at sea level on the southwestern Pacific coast of British Columbia. In general, Vancouver has a temperate climate with mild temperatures and moderate humidity levels year round. Summers are pleasantly warm and dry and winters are relatively mild with high levels of precipitation. This weather pattern is due to the combination of the nearby ocean and the protection from the cold continental winter offered by the Coast Mountains rising abruptly from the ocean immediately to the north of the city.

The following table shows the average minimum and maximum air temperatures for Vancouver during the coldest month (January) and the hottest month (August).<sup>4</sup>

**Table 1: Vancouver Average Temperatures**

January		August	
Average Minimum	Average Maximum	Average Minimum	Average Maximum
0.5 °C	6.2 °C	13.2 °C	21.9 °C

<sup>4</sup> Source: <http://www.climate.weatheroffice.ec.gc.ca>

Because Vancouver is on the Pacific Northwest coast and it rains frequently, we often refer to Vancouver as “humid.” However, only Vancouver’s relative humidity is consistently high, not its absolute humidity. When high relative humidity coincides with low temperatures, the absolute amount of moisture in the air is still low. See Appendix C.2 for a more detailed discussion of humidity in Vancouver.

Vancouver receives moderate levels of solar radiation during spring, summer and fall.

The prevailing wind direction is from the east, followed in frequency by westerly winds. Due to the protection of the Coast Mountains, north winds are marginal.

The outdoor design temperatures for Vancouver as defined by the BC Building Code (2006) and ASHRAE 90.1 v.2007 are shown in Table 2.

## 2.4 Energy Performance Targets

Minimum energy performance is defined by current North American

standards in indirect, non-energy-specific terms. The standards fall short of what is being achieved in other parts of the world and what is possible in our Vancouver climate.

Both North American standards address only two passive building components: envelope insulation and window performance. Neither standard addresses other crucial passive design parameters affecting energy performance such as building shape, compactness, orientation, layout, and thermal storage effects of building mass.

The currently prescribed methodology does not provide clear, measurable energy performance targets. It is not possible to compare energy performance between buildings or determine how a building compares to the best energy performance in a given climate.

Establishing building energy performance targets in clear and measurable terms is a fundamental prerequisite of successful passive design. This new methodology has already been successfully

**Table 2: Vancouver Outdoor Design Temperatures**

	BCBC	ASHRAE
Winter Dry Bulb Temperature, 99.6%	-9°C	-8°C
Summer Dry Bulb Temperature, 1%	26°C	23°C
Summer Wet-Bulb Temperature (max coincident with 23°C dry-bulb)	19°C	18°C

5 In general, ASHRAE 90.1 is used in the US, and the Model National Energy Code of Canada for Buildings (MNECB) is used in Canada. However, local Canadian jurisdictions can choose to supersede MNECB, as Vancouver has done by adopting ASHRAE 90.1 v.2007.





implemented in most of Europe.<sup>6</sup> Minimum building energy performance is prescribed in terms of energy intensity, kWh/m<sup>2</sup>·year, for a specific building type in a specific climate. Maximum allowable energy intensity targets can either be determined from the historical building energy consumption data or derived from fundamental laws of physics such as with the free-run temperature methodology.

It is recommended that the City of Vancouver adopt maximum allowable energy intensity targets for specific building types. At present (late 2008), the City of Vancouver is working with BC Hydro and Terasen Gas to gather energy intensity data on existing buildings. Once an adequate and accurate data set has been collected, the City will be able to set energy intensity targets appropriate to the Vancouver climate and building market.

## 2.5 Integrated Design Process

Optimized building design requires the integration of many types of information from diverse sources into a comprehensive whole throughout the project. The Integrated Design Process (IDP) ensures all issues affecting sustainable performance are addressed throughout the process, from conception to occupancy. It is most critical to implement the IDP early on in the design activities, when issues can be addressed with minimal disruption. Active, consistent and coordinated collaboration between all team members and disciplines is critical to a successful IDP.

When implementing a passive design approach, many disciplines must collaborate to have the building and its surrounding site working together as a passive system. Figure 2 illustrates some of the many possible members of an IDP team.

Figure 2: Integrated Design Process Team

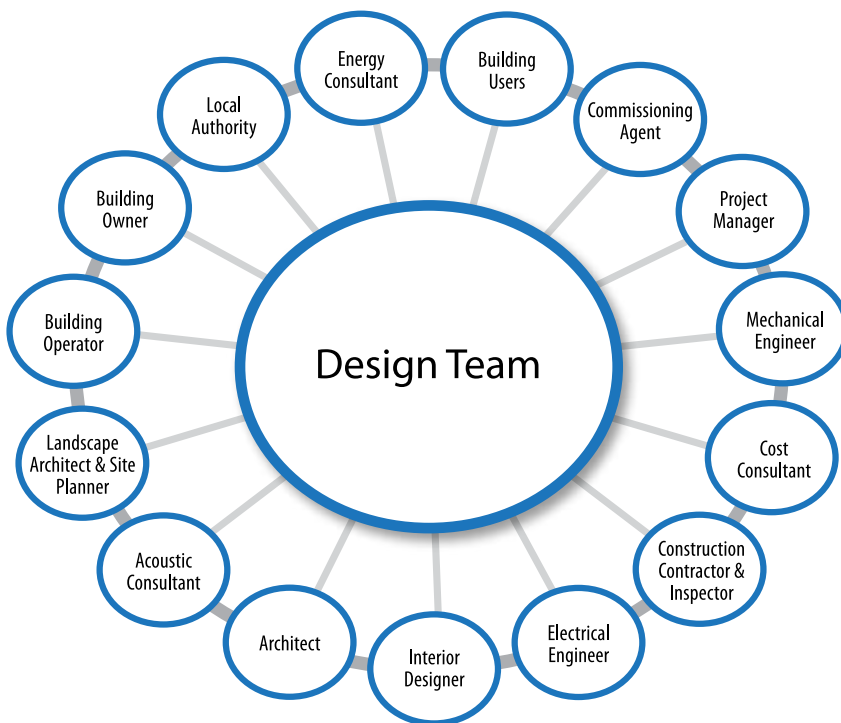

<sup>6</sup> European Energy Performance of Buildings Directive, MINERGIE (originated in Switzerland), Passive Haus (originated in Germany), etc.

# 3 Passive Design Strategies

Certain passive building elements have inherent synergies and can be combined to produce different and potentially greater improvements in comfort and building energy performance.

However, combining elements incorrectly or using certain elements in isolation can negatively impact thermal comfort and building energy efficiency. For example, large south and west facing windows beneficial for passive solar heating must be implemented in combination with high performance windows and external shading to protect the interior from excessive solar heat gains during summer in order to achieve the desired overall building efficiency gains.

It is important to note that these guidelines distinguish between cooling and ventilation. In a conventional forced-air HVAC system, ventilation and space temperature control functions are combined. However, there are great advantages to separating the function of space temperature control from the function of ventilation, especially when designing for optimal passive performance. This separation allows the choice of a hydronic heating and cooling system, using water instead of air for energy transfer. Water has over 3,000 times the energy carrying capacity of air, so hydronic systems can achieve dramatically increased system efficiency. The separation also allows the use of an independent ventilation system providing 100% fresh air.

Figure 3 below shows an example of the compounding effect of combining various passive elements on a typical building in Vancouver as thermal comfort is held constant. The baseline meets the minimum requirements of ASHRAE Standard 90.1. As each additional element is incorporated, the annual energy consumption is further reduced, finally achieving a high level of efficiency that would be impossible using any single measure in isolation. The passive design measures essentially build upon and improve the requirements and results of most commonly used North American energy standards methodologies.

Figure 3: Effect of Passive Design on Energy Intensity

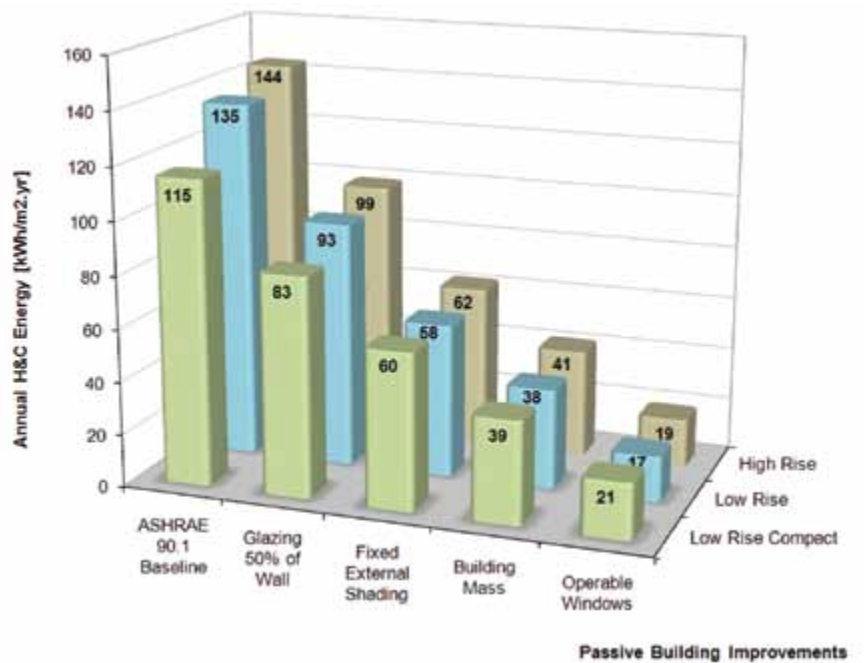



## CASE STUDY

Turn to page 102 to learn how the Millennium Water development takes advantage of cross-ventilation.

With many passive strategies, there is a tradeoff between heating performance and cooling performance. The building type and operation determine which strategies will have the best overall impact on energy performance. In all cases, building energy modeling specific to the project should be conducted. Once again it is important to note that the simulation results presented in this report are parametric comparisons only; they do not replace the value of project-specific modeling.

### 3.1 Passive Heating

Using building design to harness solar radiation and capture the internal heat gains is the only passive way to add free thermal energy to a building. Passive solar heating combines a well-insulated envelope with other elements that minimize energy losses and harness and store solar gains to offset the energy requirements of the supplemental mechanical heating and ventilation systems. Elements that contribute to passive solar heating include the following:

- Orientation
- Building shape
- Buffer spaces and double facades
- Space planning
- High-performance windows (clear, low-e)
- Mixed-mode heat recovery ventilation (HRV)<sup>7</sup>

- Low window to wall area ratio (N/E)
- High window to wall area ratio (S/W)
- Operable external shading
- High-performance insulation
- Thermal mass
- Minimized infiltration

### 3.2 Passive Ventilation

Passive ventilation strategies use naturally occurring air flow patterns around and in a building to introduce outdoor air into the space. Wind and buoyancy caused by air temperature differences create air pressure differences throughout occupied spaces. Buildings can be designed to enhance these natural air flows and take advantage of them rather than work against them.

Passive ventilation must be considered during the design process because many architectural features affect air flows through a building, including the building shape, layout of interior walls, floors and even furniture. Design features must strike a balance between privacy/noise attenuation needs and the desired path of least resistance for air distribution. Ventilation rates will also be affected by prevailing wind direction.

There are three common approaches to passive ventilation. The simplest form is single-sided ventilation with operable windows, where ventilation air enters and exhausts through the same window(s) on the same side of

<sup>7</sup> HRV is an active system; however, due to its effective synergies with passive ventilation, we are mentioning it here. See Appendix E for modeling results on the efficiency of this mixed-mode system.

the occupied space. There are design limitations on how large a space can be effectively ventilated this way: single-sided ventilation does not achieve a significant result unless ceilings are very high.

More effective is cross-ventilation, where operable windows on adjacent or opposing walls draw ventilation air across the occupied space. Designs should strive for at least two exposed walls per residential or commercial unit to allow for cross-ventilation.

Finally, in larger buildings with significant core spaces, induced ventilation with high spaces such as atria, stacks and wind towers may be necessary to provide adequate ventilation by strictly passive means. These strategic architectural features create optimized pathways for natural, passive ventilation.

The passive elements that contribute to natural ventilation include the following:

- Operable windows
- Buffer spaces and double facades
- Building shape
- Space planning
- Orientation
- Strategic architectural features
- Openings to corridors and between otherwise separated spaces
- Central atriums and lobbies
- Wind towers

Figure 4: Single-Sided Ventilation

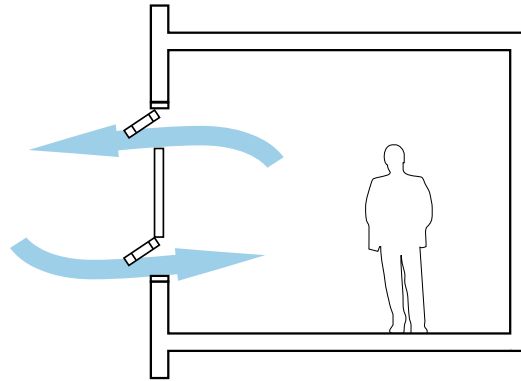

Figure 5: Cross Ventilation

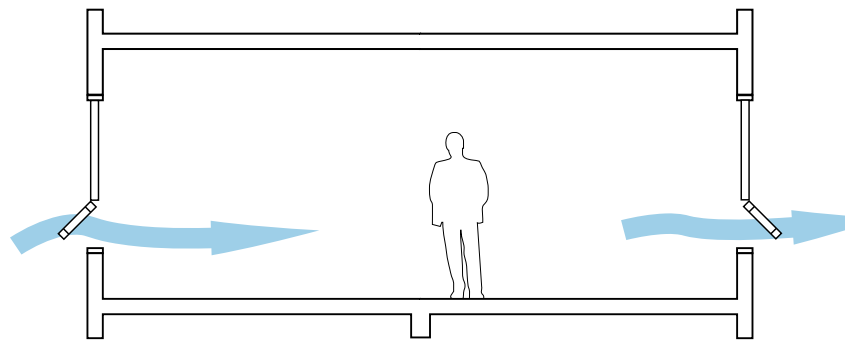
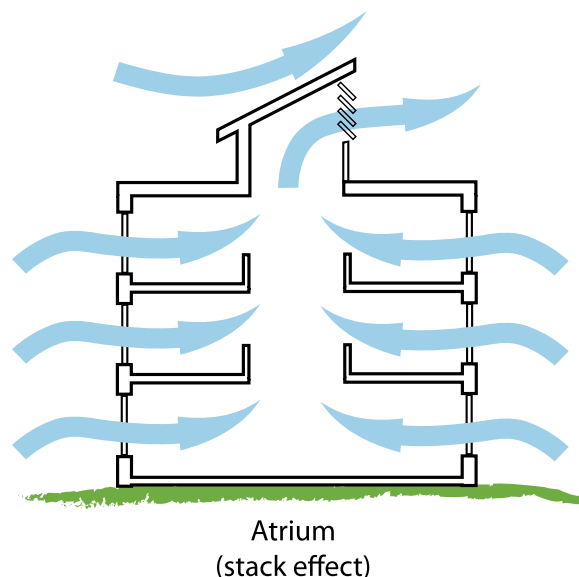

Figure 6: Stack Effect through an Atrium





□ Careful design is required to avoid overheating from direct solar gains and to minimize glare.

### 3.3 Passive Cooling

Passive cooling strategies prevent the building from overheating by blocking solar gains and removing internal heat gains (e.g. using cooler outdoor air for ventilation, storing excess heat in thermal mass).

Passive cooling strategies are often coupled with passive ventilation strategies, and the cooling function is achieved by increased passive ventilation air flow rates during periods when the outdoor air temperature is low enough to flush heat from the building.

Elements that contribute to passive cooling include the following:

- Fixed/operable external shading
- Thermal mass
- Low window to wall area ratio (S/W)
- Passive ventilation
- Nocturnal cooling
- Stacked windows
- Passive evaporative cooling
- Earth-tempering ducts

Nocturnal cooling uses overnight natural ventilation to remove heat accumulated in the building mass during the day. The cooler night-time air flushes and cools the warm building structure/mass.

Stacked windows allow cool air in at a lower window, creating an upward-moving vacuum that forces warm air out a high-placed window.

Evaporative cooling uses heat from the spaces to convert water from a liquid to a vapor, which changes the air from warm and dry to cool and moist. In order to cool a space by evaporative cooling, moisture must be added to an airstream. This can be achieved by drawing air across or through existing water (e.g., a water feature located within the building, a natural exterior body of water, a hydroponic living wall, etc.).

Earth tempering takes advantage of the relatively constant temperature of the ground at depths exceeding 1.5 m to provide tempering for building ventilation air. This requires burying a ventilation air intake path, also called an earth tube.

### 3.4 Daylighting

Daylighting maximizes the use and distribution of natural diffused daylight throughout a building's interior to reduce the need for artificial electric lighting. Careful design is required to avoid overheating and to minimize glare, and to complement passive heating and cooling strategies such as shading. In order to maximize energy savings, advanced electrical control systems like sensors should be integrated. The features which contribute to a daylighting strategy include:

- Space planning
- High ceilings paired with tall windows
- Window size and placement (window to wall area ratio)
- Interior surface colours and finishes
- Strategic architectural features
- Light shelves
- Skylights and light tubes
- Clerestories

The key energy savings benefit of daylighting is straightforward: daylighting reduces energy requirements for electrical lighting. Indirectly, daylighting can also reduce energy requirements for space cooling.

Daylighting strategies are highly project-specific: detailed building modeling and analysis is required to achieve an effective design and to estimate energy savings. As such, daylighting is not included in the parametric simulations of this study.

### 3.5 Applying the Strategies: Residential

In the Vancouver market, the vast majority of residential developments are medium- and high-rise towers. Residential spaces have night-time occupancy and relatively low internal heat gains (aside from intermittent cooking), which results in a heating-dominant residential energy profile in the Vancouver climate.

Specific passive approaches that will improve the overall energy performance of residential buildings in Vancouver include:

- Carefully detailed and constructed high-performance insulation in the envelope with minimal thermal bridging, including exterior walls and roofs.
- Clear, low-e, high-performance windows in combination with operable external shading to block solar gains during summer and admit solar gains during shoulder seasons and winter
- Note: any building in which the window to wall area ratio is greater than 50% will be challenged to achieve higher energy performance
- Unconditioned, enclosed buffer spaces (not regularly occupied) that cover the perimeter of the space, fitted with operable windows to provide natural ventilation from the exterior to the interior space when desired.
- Thermal mass on the interior side of the insulation, located in the floors, external walls, and walls between adjoining units (i.e., party walls).
- Compact and simple form.
- Air- and moisture-tight envelope.
- Mixed-mode ventilation using HRV during the winter only and passive ventilation throughout the rest of the year.

The following table displays the elements that positively contribute to the various passive design strategies for residential buildings.

	Relative Impact (★)	Passive Heating	Passive Cooling	Passive Ventilation	Daylighting
High-performance insulation	★ ★ ★	•	•		
High-performance windows	★ ★	•	•		•
Window to wall area ratio <50%	★ ★ ★	•	•		•
Buffer spaces	★ ★ ★	•	•	•	•
External shading	★ ★ ★		•		•
Thermal mass	★ ★	•	•		
Compact form	★	•			
Air- and moisture-tight envelope	★ ★	•			

These features were added to the parametric model one at a time to clearly illustrate the compounding benefit of each. Refer to modeling results in Appendix E.

### 3.6 Applying the Strategies: Commercial

Commercial buildings have different characteristics from residential buildings, such as greater internal heat gains from equipment and lighting, higher ventilation requirements, and different occupancy trends. Commercial buildings benefit from passive cooling, but in the Vancouver climate, design must strike a balance between heating and cooling performance.

Specific passive approaches that will improve the overall energy performance of commercial buildings in Vancouver include:

- Carefully detailed and constructed high-performance insulation in the envelope with minimal thermal bridging, including exterior walls and roofs.
- Solar gain control using either high-performance windows with low shading coefficient (tinted or reflective) or clear high-performance windows with a low-e coating in combination with operable external shading to block solar gains during summer and shoulder seasons and admit solar gains during winter.
- Window to wall area ratio limited to <50%.
- Double facades with operable shading elements and operable windows to act as thermal buffer spaces, preheat ventilation air in the winter, and block solar gains and provide natural ventilation in the summer.
- Building shape and massing that enhances natural ventilation and daylighting, ideally with central atriums and ventilation towers.
- Thermal mass on the interior side of the insulation, located in the floors, external walls, and walls between adjoining units (i.e., party walls).
- Passive cooling strategies, such as nocturnal ventilation to pre-cool spaces during summer and ventilation air intakes located in cool areas and delivered to the building using earth tubes.
- Air- and moisture-tight envelope.

The following table displays the elements that positively contribute to the various passive design strategies for commercial buildings.

	Relative Impact (★)	Passive Heating	Passive Cooling	Passive Ventilation	Daylighting
High-performance insulation	★★	•	•		
High-performance windows	★★★	•	•		•
Window to wall area ratio <50%	★★★	•	•		•
Double facades	★★	•	•	•	•
External shading	★★★		•		•
Narrow forms	★		•	•	•
Thermal mass	★	•	•	•	
Nocturnal ventilation	★★		•	•	
Pre-cooled ventilation air	★★		•	•	
Air- and moisture-tight envelope	★★	•			

These features were added to the parametric model one at a time to clearly illustrate the compounding benefit of each. Refer to modeling results in Appendix E.

### 3.7 Modeling Summary

Our modeling results indicate that incorporating passive elements and strategies effectively expands the range of outdoor conditions under which buildings can remain comfortable without active systems.

The figure below shows this effect of passive design strategies relative to the ASHRAE Comfort Zone. When outdoor conditions fall within the extended passive zone, a building that incorporates all of these passive

strategies will be comfortable without mechanical heating or cooling; when conditions fall outside of the zone, the building must rely on active systems to maintain thermal comfort.

In conclusion, passive design enables buildings to maintain occupant comfort throughout more of the year using less energy.

For the quantitative impact of individual passive elements and strategies, refer to Appendix E.

**Figure 7: ASHRAE Comfort Zone and Achievable Extended Comfort Range by Passive Design Strategies in Vancouver Climate**

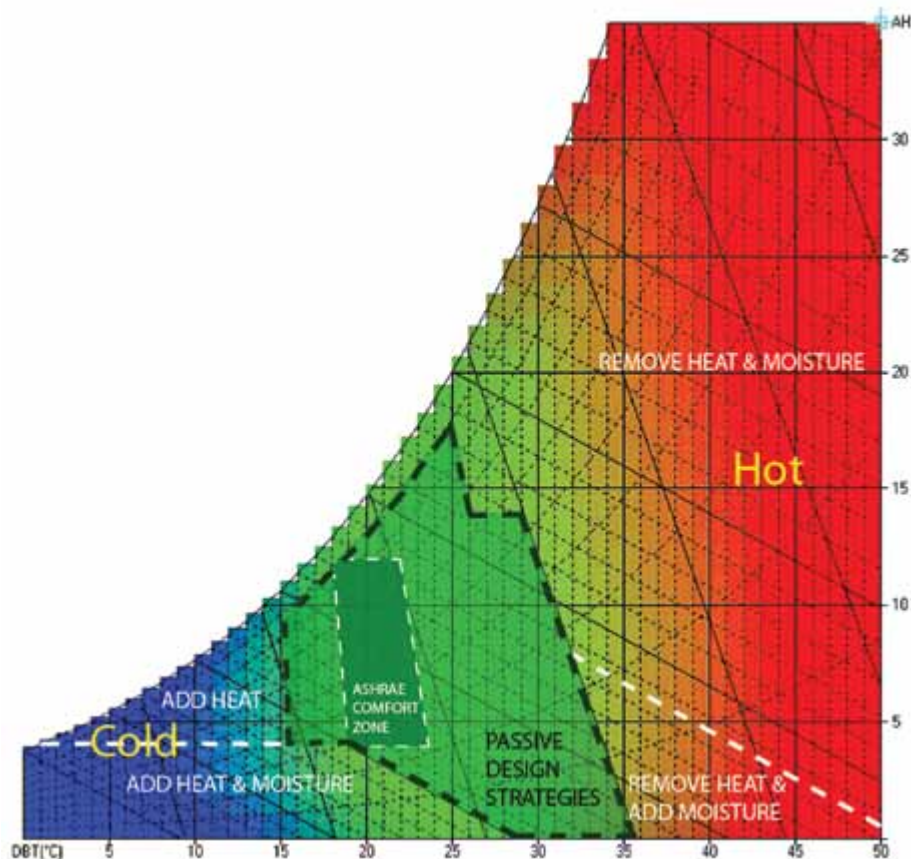



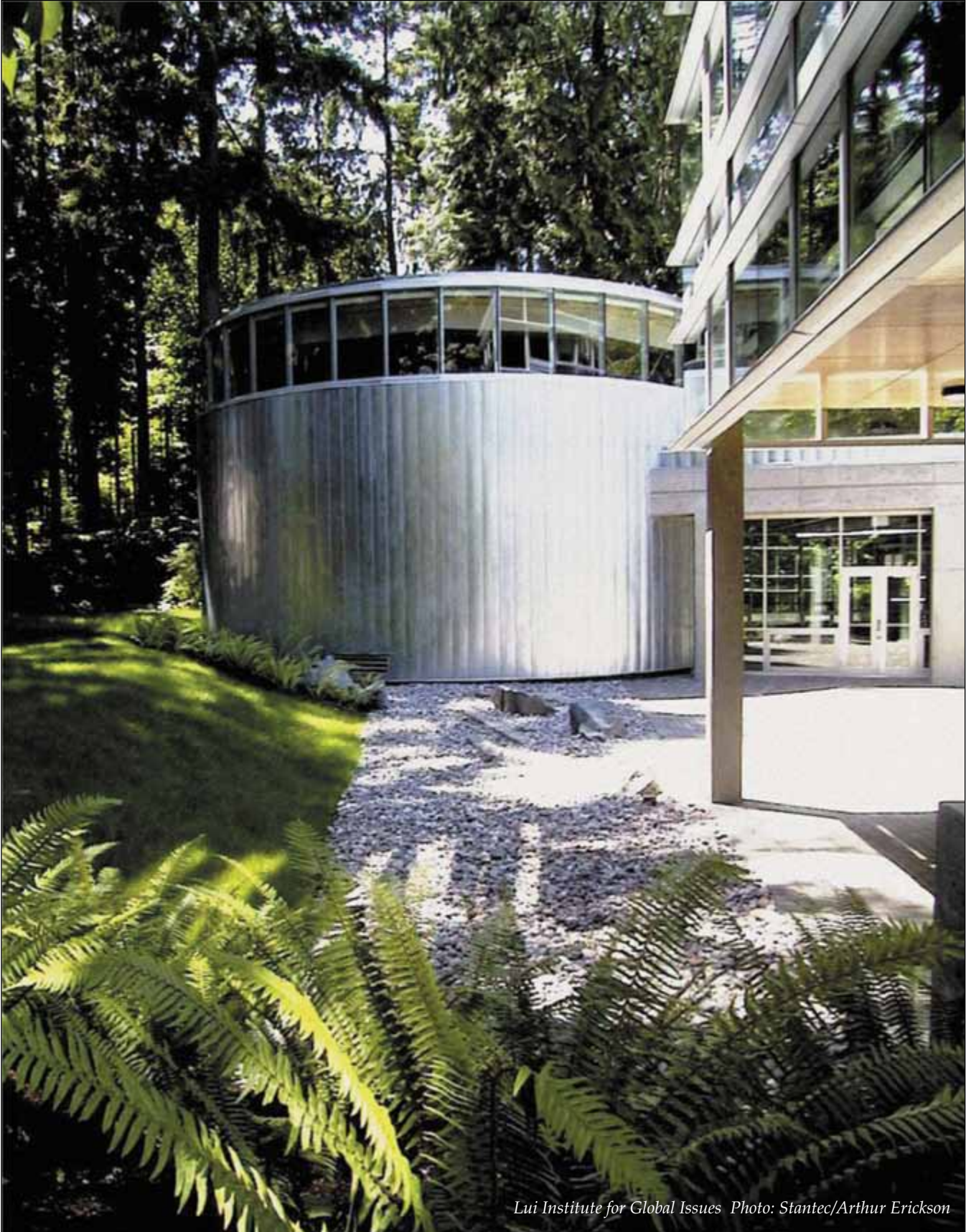

*Lui Institute for Global Issues Photo: Stantec/Arthur Erickson*

# 4 Passive Design Elements

The primary objective of passive design strategies is to reduce or even eliminate the need for active mechanical systems while maintaining or even improving occupant comfort. The passive design strategies discussed in Section 3 integrate the complementary passive design elements that follow to minimize heating and cooling loads. Performance of each individual passive element is discussed here in Section 4. They are presented in the general order a designer would encounter them throughout a design.

- Site and Orientation
- Building Shape and Massing
- Landscape Considerations
- Space Planning
- Buffer Spaces
- Windows
- Solar Shading
- Thermal Mass
- Thermal Insulation
- Air and Moisture Tightness

## 4.1 Site and Orientation

### 4.1.1 Overview

Many site considerations can affect the passive design approach, including urban design opportunities and constraints, building orientation on the site, shade from other buildings, wind patterns, proximity to industry, noise, and urban character. These all need to be considered to optimize the integration of passive design strategies and some may pose design conflicts. On the



other hand, the integration of site considerations such as landscaping, wind and microclimate can influence the local architectural expression of a building.

Building facade orientation is one of the key elements for many passive design strategies. Facade orientation affects the energy and comfort implications of solar shading, window to wall area ratio, window position and performance, and choice of exterior colour.

A building's orientation determines the amount of solar radiation it receives. The roof surface receives the greatest intensity, but it is normally opaque and well-insulated. Building facades, which can have a significant window to wall area ratio, also receive sun in various amounts. The south facade will capture desirable solar gains during winter when the sun angle is low, making it ideal for passive solar heating during winter. On the other hand, window should be carefully placed on the east and west facades since they receive the second highest radiation intensities. Excessive solar heat gains on the west side can be particularly problematic as maximum solar intensity coincides with the hottest part of the day.

□ The primary objective of passive design strategies is to reduce or even eliminate the need for active mechanical systems while maintaining or even improving occupant comfort.



Figure 8: Vancouver’s Two Distinct Grid Orientations



Figure 9: Seasonal Sun Paths

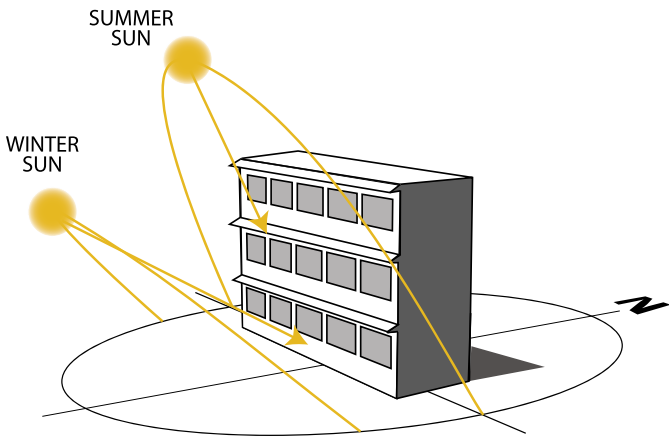
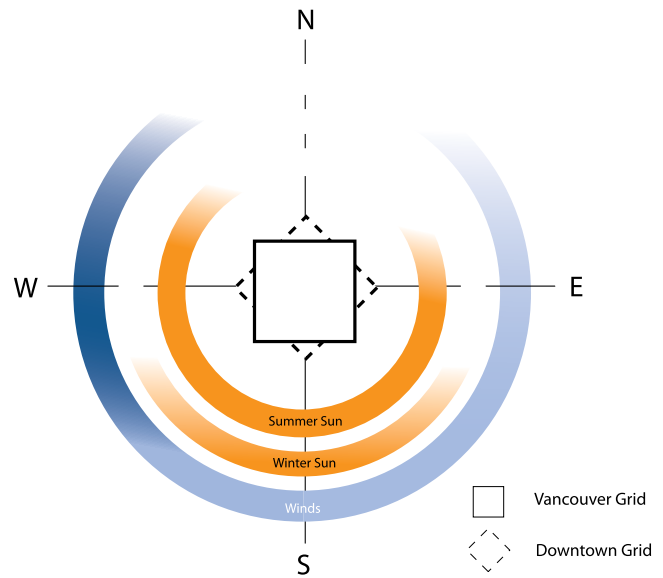

Figure 10: Facade Considerations



**4.1.2 Benefits**

- Can greatly improve heating and cooling performance when optimized.
- Can greatly improve daylighting when optimized.

**4.1.3 Limitations**

- Designing to optimal orientation is not always possible under specific urban conditions, typically limited by roads, existing development, urban design context, lot size, and lot orientation.

- Heritage conditions and related design guidelines can create opportunities for unique responses in the delivery of a passive design solution.

#### 4.1.4 Synergies

Since many passive design strategies are affected by orientation, responding to the different conditions of each facade is the most fundamental design decision a project team can make to passively design a building. For example, orientation and daylighting are very much linked. Optimum orientation will provide adequate daylight without glare or excessive solar gain.

#### 4.1.5 Vancouver Applications



Orientation that allows winter solar gains is desirable; therefore south-facing orientation is appropriate provided that it is well-shaded during summer.

Orientation will often not be optimum in the downtown grid. However, responding to the various facade conditions will significantly increase thermal comfort and decrease active mechanical system requirements.

## 4.2 Building Shape and Massing

### 4.2.1 Overview

Building shape and massing<sup>8</sup> have great potential to reduce building energy intensity, but they often fall under the influence of a complex array of factors (planning considerations, building type and use, feasibility and initial cost). Certain common building shapes greatly increase envelope area to volume ratio (e.g., thin high-rise towers), which can decrease building energy performance in heating dominant buildings. With a similar square footage, buildings with a smaller exterior envelope area will achieve better energy-efficient performance. A compact building shape significantly reduces the building's energy intensity and reduces the need for active mechanical systems as demonstrated in the modeling results shown below in Figure 11.

### CASE STUDY

Turn to page 103 to learn how the Pacific Institute for Sports Excellence's unique building shape provides solar shading.

- Building shape and massing have great potential to reduce building energy intensity.

Figure 11: Energy Intensity and Building Shape

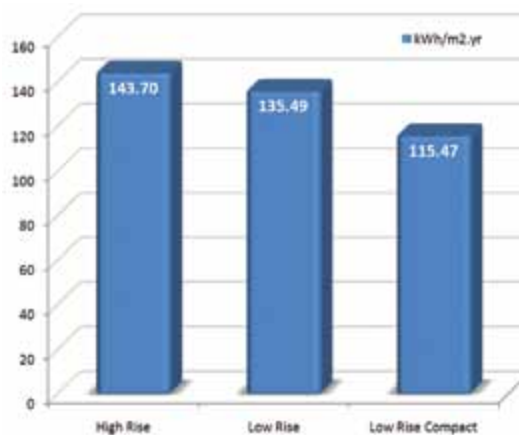

<sup>8</sup> "Massing" is used in this section to describe the overall geometry of the building. It is not to be confused with "thermal mass" (see Section 4.8).

Massing optimization can significantly improve passive performance, often without increasing the capital cost.

As one of the first design considerations, the massing of a proposed building must account for orientation and other site-specific conditions. Section 4.1 discusses orientation and its critical effects on massing and other passive design elements.

#### 4.2.2 Benefits

- Reduced heating and cooling energy consumption.
- Reduced peak heating and cooling loads.

#### 4.2.3 Limitations

- Must be carefully considered so as to not compromise the livability of the interior spaces provided (e.g., compromised daylighting; see synergies below).
- Must consider potential urban design conflicts related to street conditions, view corridors and other urban planning considerations.

#### 4.2.4 Synergies

Building massing functions in close relationship with other basic architectural passive design parameters such as orientation, envelope performance (including window location) and solar shading.

Massing must also be considered alongside daylighting needs and natural ventilation, which tend to improve in buildings with narrower profiles, courtyards and other features that increase envelope area.

#### 4.2.5 Vancouver Applications

- Heating-dominant residential buildings should be as compact as possible to improve their energy performance.
- Cooling-dominant commercial buildings should favour a longer shape along an east-west axis with more potential for passive cooling strategies.
- Buildings with compact form can be designed with features such as light wells and atriums to facilitate natural ventilation and daylighting.

**Figure 12: The effect of envelope to volume ratio on energy efficiency**

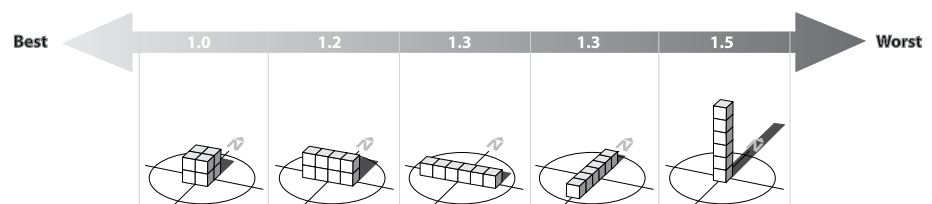

## 4.3 Landscape Considerations

### 4.3.1 Overview

Many landscape considerations happen very early on in the design process. Set backs, street trees, street alignment and use of landscape buffer zones can be guiding elements of many site planning decisions. Therefore, careful consideration of landscaping is critical to successfully implementing the passive approach at the early stages of design. The integration of landscape strategies

requires an active IDP where energy and thermal comfort goals are discussed and understood within the design team. Vegetation can help in many ways:

- Reducing ambient temperature and limiting the heat island effect around buildings, thus reducing the cooling load.
- Protecting the building from sun, wind and precipitation.
- Reducing solar intensity received by walls and roof by introducing vegetated 'green' roofs and walls.

### CASE STUDY

Turn to page 108 to learn how the new Butchart Gardens Carousel building will take advantage of its surrounding landscape.

Figure 13: Landscape strategies for passive solar heating and daylighting control

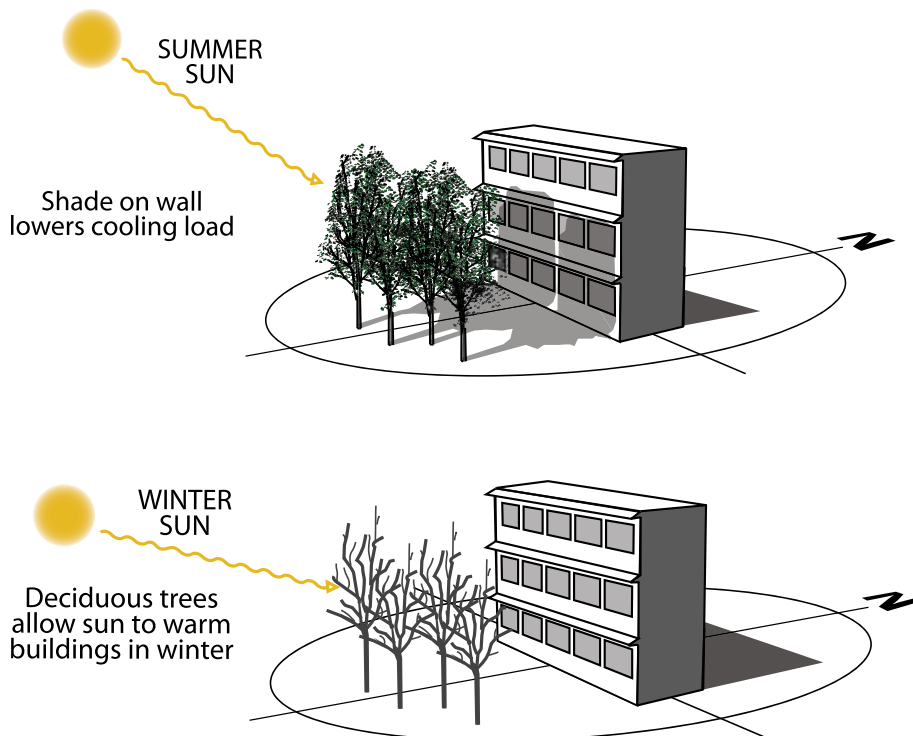

□ Deciduous trees provide cooling shade in the summer and after shedding their leaves allow for warm sun to enter the building in the winter.



**Figure 14: Reducing solar intensity with a green wall (Aquaquest at Vancouver Aquarium)**

#### **4.3.2 Benefits**

- Deciduous planting provides desirable shading during summer and allows desirable solar gains during winter while adding aesthetic appeal.
- See Synergies below.

#### **4.3.3 Limitations**

- Landscaping strategies are often limited by the available space.
- Many landscaping strategies require maintenance and irrigation.
- Incorporating landscaping strategies in higher buildings can be challenging due to maintenance and increasing challenges such as weight, wind pressure and irrigation.

#### **4.3.4 Synergies**

- Landscaping strategies can assist mechanical ventilation systems by contributing to ventilation air pre-cooling.
- Landscaping strategies can contribute to daylighting controls by reducing glare.
- Landscaping strategies can facilitate passive heating by allowing solar heat gain during winter and providing shade during summer.

#### **4.3.5 Vancouver Applications**

- Vancouver's mild, seasonal climate is very conducive to deciduous trees whose leaves provide desirable shading during summer and fall to allow desirable solar gains during winter.



## 4.4 Space Planning

### 4.4.1 Overview

Matching the program requirements with orientation and massing (building geometry) can further decrease energy use and increase thermal comfort. Building functions with particular thermal requirements should be placed in areas of the building that can provide those conditions (or come closest) without mechanical intervention. For example, computer labs or other rooms that have large internal heat gains and thus require mostly cooling should be placed on north or east-facing facades to minimize energy use from mechanical cooling.

By accounting for the thermal comfort requirements of a particular space use and matching them to suitable building characteristics, the design team can use passive design strategies to reduce building energy demand and maintain occupant comfort.

### 4.4.2 Benefits

- Locating spaces in their ideal thermal location in the building reduces mechanical heating and cooling energy by taking advantage of the building's natural thermal responses.
- Strategic space planning can reduce glare and improve comfort.

### 4.4.3 Limitations

- In many cases, such as residential units facing only one direction, it may be difficult to program the building to avoid having uses that will be negatively affected by solar gain.

### 4.4.4 Synergies

- Space planning considerations are directly linked to orientation and massing and the ability of the design team to provide, when possible, appropriate thermal conditions within the buildings.

### CASE STUDY

Turn to page 105 to learn how careful space planning helps Surrey's Revenue Canada building.

□ Locating spaces in their ideal thermal location in the building reduces mechanical heating and cooling energy.

Figure 15: Example of Strategic Space Planning

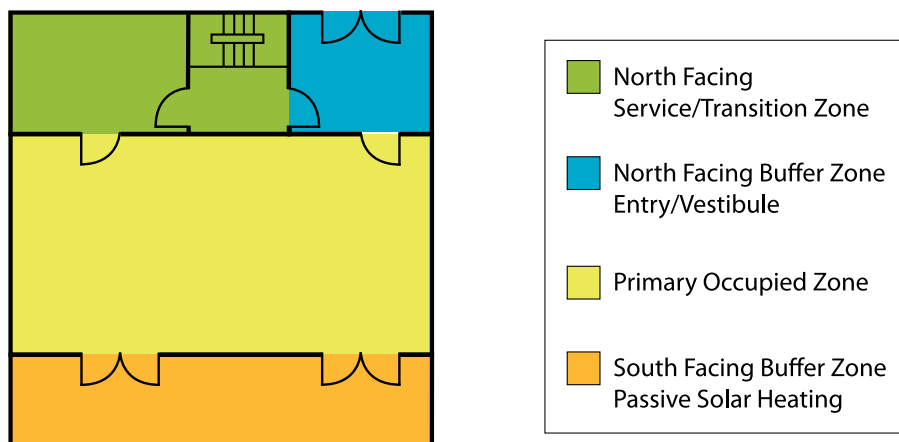

- When possible, incorporating buffer spaces to increase thermal conditions of the program areas should influence space planning decisions.

#### 4.4.5 Vancouver Applications



In the Vancouver climate, space planning should target the following conditions:

- Locate cooling dominant spaces on the north or in the centre of the building away from any perimeter solar gain.
- Locate heating dominant spaces on the south or west, avoiding over-exposure to west solar radiation.
- Locate residential spaces on the south exposure whenever possible.

### 4.5 Buffer Spaces

#### 4.5.1 Overview

Buffer spaces such as double facades and sunspaces are located along the building perimeter and can be occupied or unoccupied, as well as

semi-conditioned or unconditioned. They improve building energy performance by widening the range of outdoor temperatures in which thermal comfort can be maintained in the building with low mechanical energy consumption. Especially helpful during winter, buffer spaces create another insulation layer in front of the envelope, slowing the rate of heat loss between the outdoors and the indoor conditioned space. Ideally, they should be convertible to fully exterior space during summer to aid in ventilation and cooling of the adjoining occupied space.

Buffer spaces are a key component of many passive solar designs when they are oriented on the sunny side of the building.

South- and west-facing buffer spaces can be designed to act as occupied sunspaces, providing both passive solar heat gain and a functional occupied space. Sunspaces function like passive solar collectors, trapping solar gains like a greenhouse. Thermal storage is most effectively provided in the thermal mass of the floor and/or walls of the sunspace structure itself. Stored heat can either reach the building passively through the walls between the sunspace and the interior, or be distributed by an active mechanical system. The design and construction of sunspaces varies widely. In general, they can have open or closed ends, single or multiple slopes, and various arrangements of storage mass in the floor and walls.

**Figure 16: Examples of Possible Sunspace Configurations**

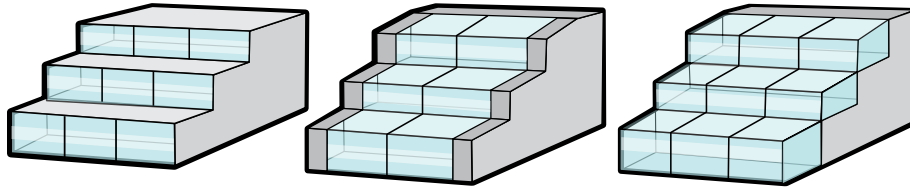

In passive heating applications, sunspaces must be designed so the solar gains are greater than the heat losses through the windows.

Integrating occupied buffer spaces as transition spaces is ideal because a wider thermal comfort range is acceptable in spaces like corridors and entryways, as opposed to other, more tightly conditioned spaces such as residential, classroom or office areas. Entryway vestibules, a mandatory requirement for many buildings under the Vancouver Building Bylaw, are also maintained at wider thermal comfort ranges, which also help to reduce the mechanical system energy consumption by limiting the loss of heated air during winter and cooled air during summer. They also improve comfort in the adjacent space by reducing or even eliminating drafts.

Unoccupied buffer spaces, such as double facades or Trombe walls, are cavities between an exterior window layer and a secondary wall or window layer, typically with controllable openings between the outdoors and the interior spaces. The openings are adjustable to either ventilate the cavity, or to transfer air between the indoors and outdoors. Double facades can

also be designed to induce stack effect and passively ventilate the occupied space. During winter the cavity can preheat ventilation air. During summer, the cavity openings can be adjusted to draw exhaust air out of the building. In the shoulder seasons, a double facade can increase the amount of time that natural ventilation can satisfy occupant comfort requirements.

#### **4.5.2 Benefits**

- Energy savings with reduced heat losses, infiltration at entries, and/or preheated ventilation air.
- Improved thermal comfort due to more stable interior space surface temperatures, reduced draft, and increased application of natural ventilation.
- Protects interior wall surface from the elements.
- Reduces building heating energy requirements via passive heating.

#### **4.5.3 Limitations**

- Buffer spaces increase the area of the building, but the space is not always usable for occupants.



- Buffer spaces may add FSR if exceeds zoning bylaw percentage.

#### 4.5.4 Synergies

Many synergies are possible with buffer spaces such as double ventilated facades. Buffer spaces in south facing double ventilated facades can be used to aid natural ventilation for example. Other passive building strategies can also work well with these types of facades such as night cooling and solar shading.

Vancouver's temperate climate makes buffer spaces an excellent design option, because they could potentially eliminate the need for mechanical cooling and dramatically reduce the amount of time the mechanical heating system operates. In addition, they can serve as seasonally convertible habitable spaces. Buffer spaces can also provide additional rain screen protection for the building envelope resulting in longer life and fewer moisture problems for the external wall assembly.

#### 4.5.5 Vancouver Applications

□ Buffer spaces create another insulation layer in front of the envelope.

Figure 17: Example of double facade as buffer space (summer performance)

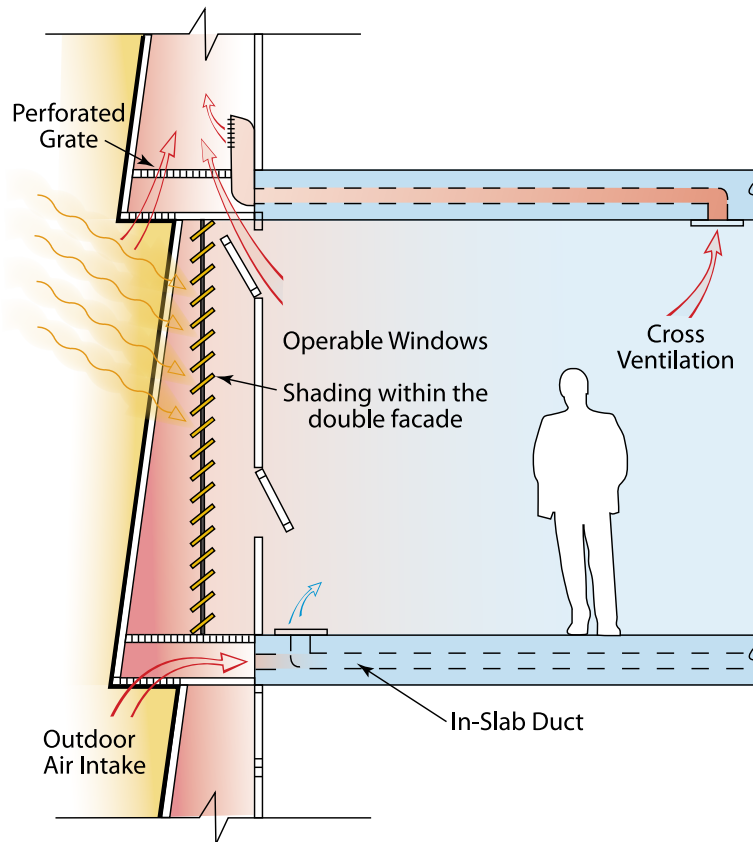

**Figure 18: Example of double facade as buffer space (winter performance)**

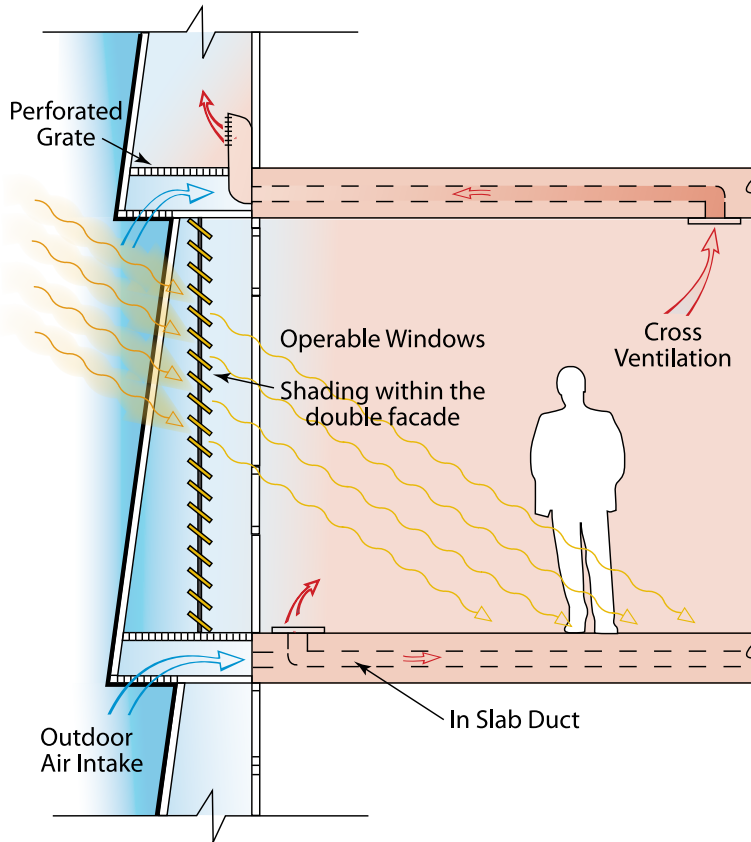

## 4.6 Windows

### 4.6.1 Overview

Windows (glazing) are necessary envelope elements in any building as they provide access to views and daylight and can be used for natural ventilation. However, window assemblies are the weakest thermal links in a building's insulated envelope, and the window design approach has a significant impact on occupant thermal comfort and building energy consumption.

In general, windows affect a building's thermal state by

transmitting solar radiation directly into the conditioned space, where it stays trapped inside and heats the interior surfaces (i.e., the greenhouse effect). This heat gain is beneficial during winter and undesirable during summer when it can overheat the space.

With respect to windows, the design requirements of heating, cooling, aesthetics and daylighting often conflict; an energy efficient design uses window materials, sizes and framing design that balance aesthetics and overall energy performance. Annual building simulations can help to identify



□ Window assemblies are the weakest thermal links in a building's insulated envelope.

#### CASE STUDY

Turn to page 106 to learn how the White Rock Operations Centre uses different window to wall area ratios on different facades.

### ***COUNCIL POLICY***

In March 2005, Council approved the Community Climate Change Action Plan to reduce greenhouse gas (GHG) emissions in the community to 6% below 1990 levels by 2012.

In March 2007, Council passed a motion directing staff to begin planning for significant, long range GHG reductions with the eventual goal of becoming a carbon-neutral city.

In May 2007, Council adopted the Building By-law (VBBL) which included environmental protection objectives. Although no new "green building" requirements were added to the by-law at that time, the environmental protection objectives were put into place to facilitate the future development of the City's Green Building Strategy.

In July 2007, Council adopted targets to reduce community GHG emissions to 33% below current levels by 2020 and 80% below current levels by 2050. In addition, Council adopted the target of having all new construction in Vancouver be GHG neutral by 2030.

In November 2008, Council passed a motion to remove 5 barriers to green building approaches and directed staff to report back when other barriers were identified and removed.

### ***PURPOSE***

The purpose of this report is to promote the adoption of passive design strategies in building design and construction in Vancouver with the goal of improving energy efficiency, and occupant comfort in order to reduce GHG emissions in Vancouver.

### ***SUMMARY***

Passive Design is a proven concept for improving energy efficiency that, to date, has not been widely employed by municipalities to reduce GHGs. Should Council accept the recommendations in this report it would be the first jurisdiction in North America to actively pursue a program that addresses the architecture of buildings to reduce GHGs beyond the application of green building codes. The staff recommendation accomplishes this in two ways: (1) through outreach and capacity building; and (2) through ongoing policy development and amendment. The Passive Design Tool Kits form the core content of the strategy and are appended to this report. (Appendix A & B)

### ***BACKGROUND***

In 2007 Council approved a work plan for staff to begin policy research and recommend by-law amendments to achieve "greener" buildings. The promotion of passive design through building policy was specifically identified in this report as a strategy for further exploration. Council has also adopted a series of ambitious targets for greenhouse gas (GHG) reductions including targets to reduce community GHG emissions by 33% below current levels by 2020 and 80% below current levels by 2050 to reflect and support adopted provincial targets. With regard to buildings in Vancouver, Council adopted the target of having all new construction in Vancouver GHG neutral by 2030.

### ***DISCUSSION***

The two Passive Design Tool Kits detail a number of strategies for achieving energy efficiency and improved thermal comfort through building design. The guides detail the strategies and

**Figure 19:  
Thermal Break**

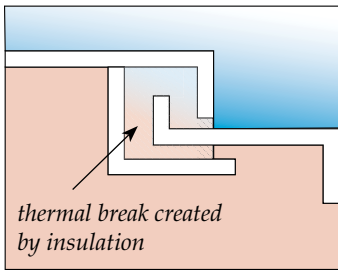

□ “Thermally broken” frames have an insulating spacer to slow the rate of heat transfer through the frame.

this optimal combination; however they cannot substitute for proper understanding of how window characteristics affect the building.

Window design characteristics fall into two categories: thermal and optical.

The thermal characteristics are the insulation or U-value, the framing type, overall area of windows, and the amount of framing.

- The number of panes of glass and the gas or vacuum void between them defines the amount of insulation provided by the windows, referred to as U-value. The U-value affects the amount of heat that is transferred between the interior and exterior, as well as the window interior surface temperature. Glass that insulates better traps more heat in the building and keeps a higher internal surface temperature, which is beneficial during winter and undesirable during summer.
- The overall window to wall area ratio is the window characteristic with the most significant impact on building energy consumption. Even the best performing glass insulates poorly when compared to an insulated wall. On east, south, and west exposures, greater window areas will admit more solar gain during winter. However, in the Vancouver climate, the net annual effect of any window to wall area ratio greater than 10% is still a thermal energy loss, even with the higher level of solar gains (see simulation results in Appendix E).
- Frames hold the glass panes and link them with the wall. They are usually made of highly conductive metal, creating thermal bridges between the interior conditioned space and the outdoors, further speeding heat loss through the window assembly. Frames can be made of less conductive materials, such as wood and vinyl. “Thermally broken” frames have an insulating spacer to slow the rate of heat transfer through the frame. However, even with a thermal break, frame material and design always limits the thermal performance of the overall window assembly. The minimum amount of framing structurally required is directly proportional to the area of windows; in addition to the minimal structural requirements, framing design is also guided by the envelope aesthetic, sometimes resulting in more framing than is necessary. The effects of thermal bridging should be minimized by reducing the amount of framing wherever possible. The thermal photo in Figure 20 demonstrates the effect of thermal bridging in window framing.

**Figure 20: Thermal Image Showing Thermal Bridging in Window Framing**

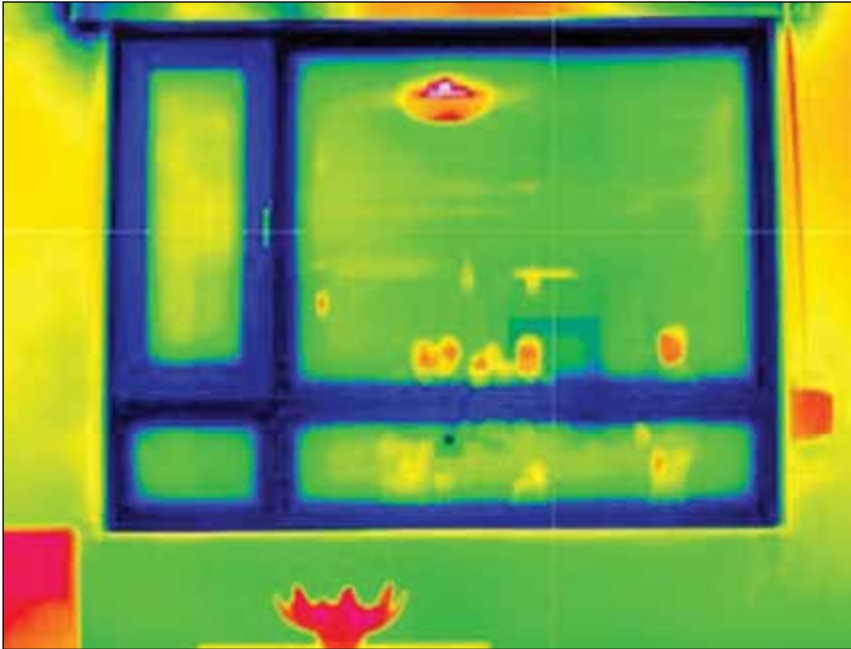

The optical characteristics of windows are defined by the glass material and the location of surface treatments such as coatings, tinting or colours. The overall optical performance of windows is typically described by the shading coefficient or solar heat gain coefficient, representing the amount of light and heat the window transmits, absorbs, and reflects. (A window with a low shading coefficient value blocks a high amount of solar radiation.) As these are fixed characteristics that can not be modified with the seasons, they have to strike a balance between the desirable shading during summer and the benefits of solar gains during winter.

The size, location, type and detailing of windows affects the thermal comfort and supplemental

heating and cooling energy consumed by the building. Therefore, window design must consider and balance the desire for floor to ceiling glass and the ongoing energy consumption that will be created by such window area and material characteristics.

### **Benefits**

- Good insulation values reduce heating energy consumption.
- Optimized shading properties reduce cooling loads in commercial building.
- Optimized insulation values and framing design reduce heat losses and condensation in residential and high-humidity applications (i.e. food preparation).

- Optimized window to wall area ratios result in greater levels of thermal comfort from smaller cold/hot surface areas.
- Optimized window to wall area ratios can reduce both heating and cooling energy demands.
- Smaller window areas make better quality windows more feasible economically.

### Limitations

- Higher capital cost of high performance glass.
- Window to wall area ratios of greater than 50% (including floor-to-ceiling glass) will greatly challenge the energy efficiency of a building. Buffer spaces should be explored in this design scenario.

### Synergies

- High performance windows should be combined with natural ventilation strategies to relieve heat gains.
- Window to wall area ratio impacts decisions on shading, window performance, thermal insulation, thermal mass, orientation and programming.

### Vancouver Applications

For residential buildings the most effective combination involves a double-pane window assembly with a low-e coating for good winter

performance in combination with external shading elements (rather than windows with a low shading coefficient) for good summer performance.

Commercial buildings with high internal heat gains will benefit from double pane windows with a low shading coefficient and a low-e coating.

From a building energy perspective, windows should be located to admit solar radiation during winter to aid the mechanical heating system and be designed to limit the amount of heat lost due to the poor insulating value of glass.

## 4.7 Solar Shading

### 4.7.1 Overview

Solar shading elements can be applied to the exterior or interior side of the windows.

External solar shading is the use of overhangs, blinds, louvers, trellises, or anything else that blocks the sun's rays from heating the building envelope and entering the building through windows.

Internal solar shading features, typically internal blinds, are any material that blocks the sun's rays at the perimeter but inside the building.

The distinction between internal and external shading is important because, although both systems block solar radiation, they have

### CASE STUDY

Turn to page 107 to learn how the Dockside Green development uses exterior solar shading.



different effects on the building aesthetic, day lighting, comfort, and building energy system requirements.

**External shading** devices intercept, absorb and/or reflect solar radiation before it reaches the exterior surface of the building envelope. When used in front of opaque envelope assemblies, external shading results in lower external surface temperatures and less heat gain through the envelope. When used on transparent envelope assemblies (i.e., windows), shading reduces the amount of direct solar gain in the space, reduces both the external and internal surface temperatures of affected windows, floors and walls, and reduces glare in the space.

**Internal shading** also blocks solar radiation from penetrating into the conditioned space; however the solar energy is still transmitted through the window assembly. Once inside, it heats the internal surface of the glass and the blinds. These warm surfaces will heat the interior space and occupants through radiant and convective heat transfer (i.e., greenhouse effect). If mechanical cooling is used, this heat gain needs to be removed by the system.

Effective shading design requires a balance between admitting desirable solar gains during winter and blocking undesirable solar gains during summer. The optimal shading strategy would be adjustable for different times

of the year. Fixed features such as horizontal overhangs are designed to admit low-angle winter sun and block high angle summer sun.

**Figure 21: Effects of Internal and External Shading**

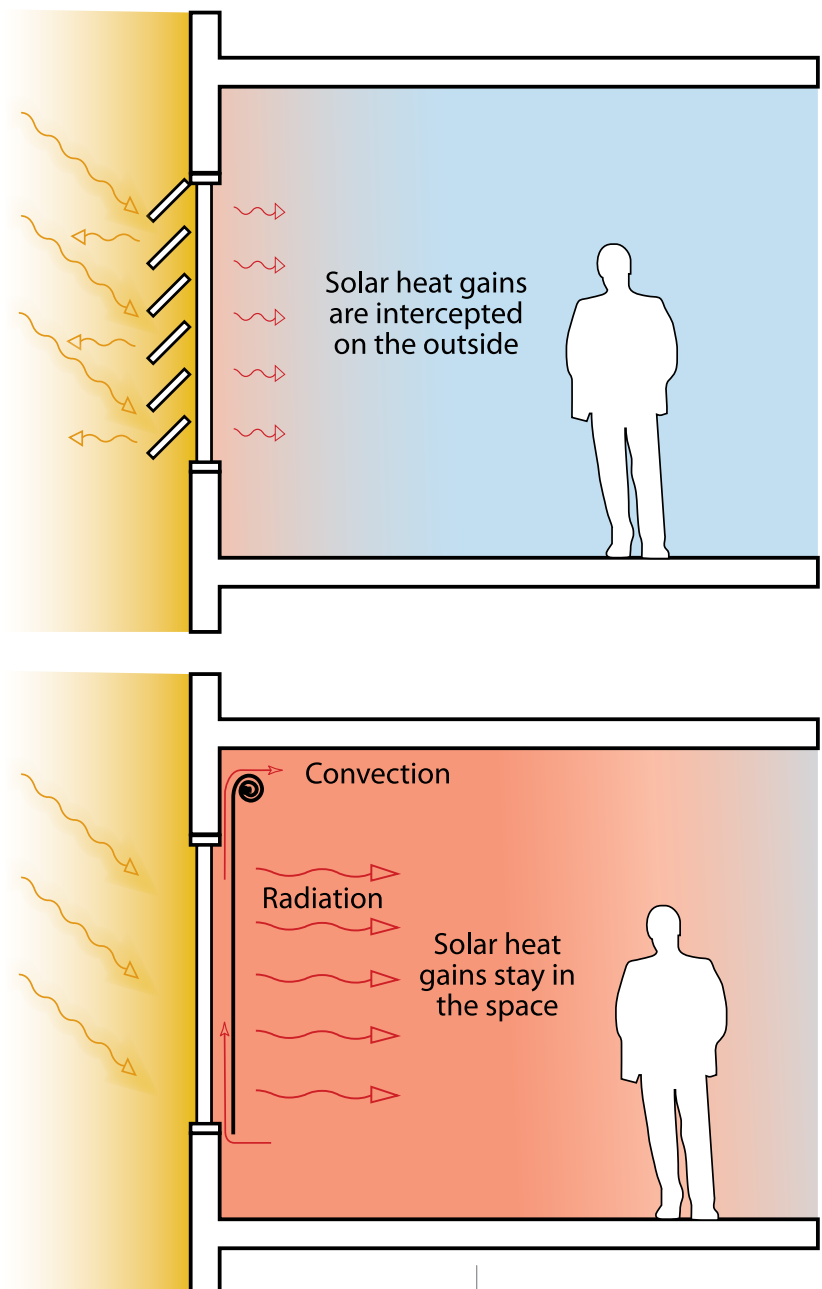

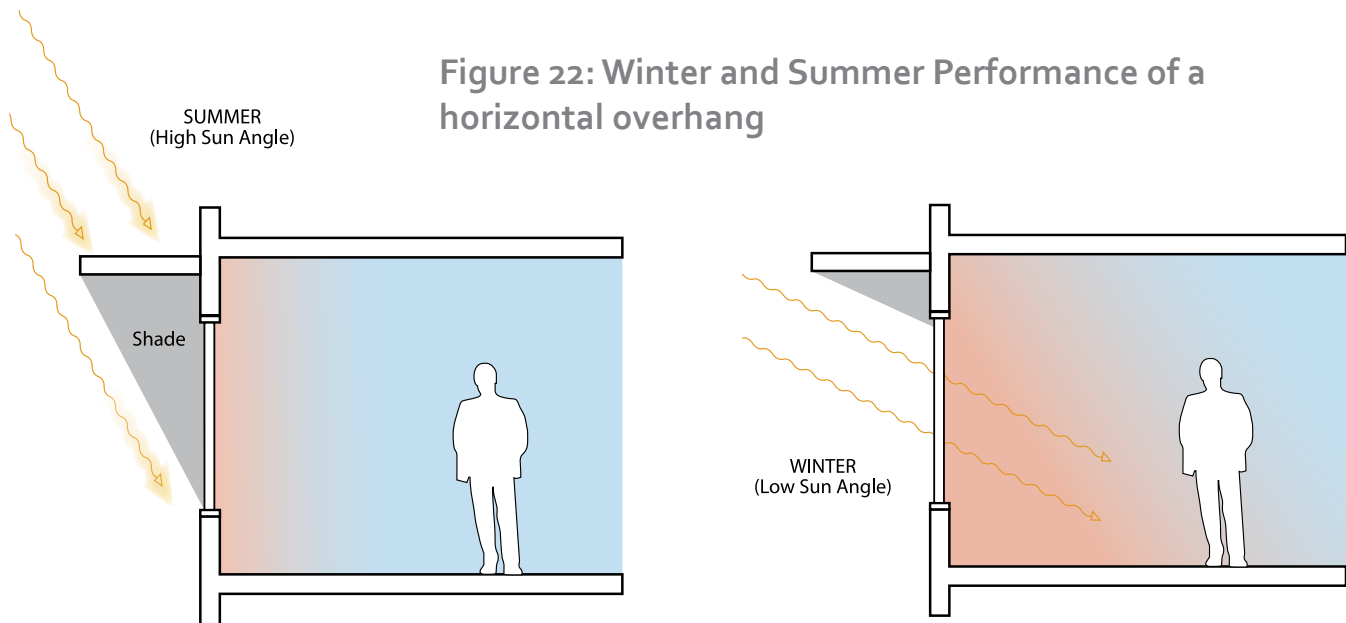

**Figure 22: Winter and Summer Performance of a horizontal overhang**

#### 4.7.2 Benefits

- Reduced demands on, and potentially eliminates the need for, active cooling systems.
- Reduced glare and improves thermal comfort by blocking direct solar gains.

#### 4.7.3 Limitations

- The benefit of blocking direct solar gains in summer must be balanced with the desired benefit of solar heat gains in winter.

- Designers must consider practical issues such as window washing.

#### 4.7.4 Synergies

- Building Orientation
- Daylighting

#### 4.7.5 Vancouver Applications

- Shading elements should be designed according to their particular facade orientation and keeping in mind seasonal temperature variations and the changing angle of the sun.
- When designing fixed shading devices, it is important to consider how they will provide the appropriate performance to meet both winter heating and summer shading/cooling requirements.

### 4.8 Thermal Mass

#### 4.8.1 Overview

All matter has thermal mass, however when used in reference to a building, thermal mass generally means materials capable of absorbing, holding, and gradually releasing heat (thermal energy). Thermally massive materials absorb

#### CASE STUDY

Turn to page 104 to learn how UBC's Liu Institute for Global Issues takes advantage of thermal mass.

heat and slowly release it when there is a temperature difference between the mass and the surrounding space. When incorporated in a wall, for example, the mass acts as a heat sink, absorbing the heat and slowing its transfer through the wall.

Heavy, dense building materials with high specific heat like stone, concrete, brick, or adobe have high thermal mass. Lightweight, porous materials such as wood, insulation, and glass have low thermal mass.

During summer, thermal mass exposed to the interior absorbs

heat from the space, including solar gains, and lowers the load on the mechanical cooling system. A thermally massive floor in a day-occupied building, for example, can be cooled overnight with cooler outdoor air. In the morning the cool mass will absorb solar and other heat gains from the space, providing the sensation of coolness from the floor. This has been shown to delay the onset of daily mechanical cooling and in some cases reduce or even eliminate the peak cooling demand. This delay is referred to as “thermal lag.”

□ Thermally massive materials absorb heat and slowly release it when there is a temperature difference between the mass and the surrounding space.

Figure 23: Effects of Thermal Mass

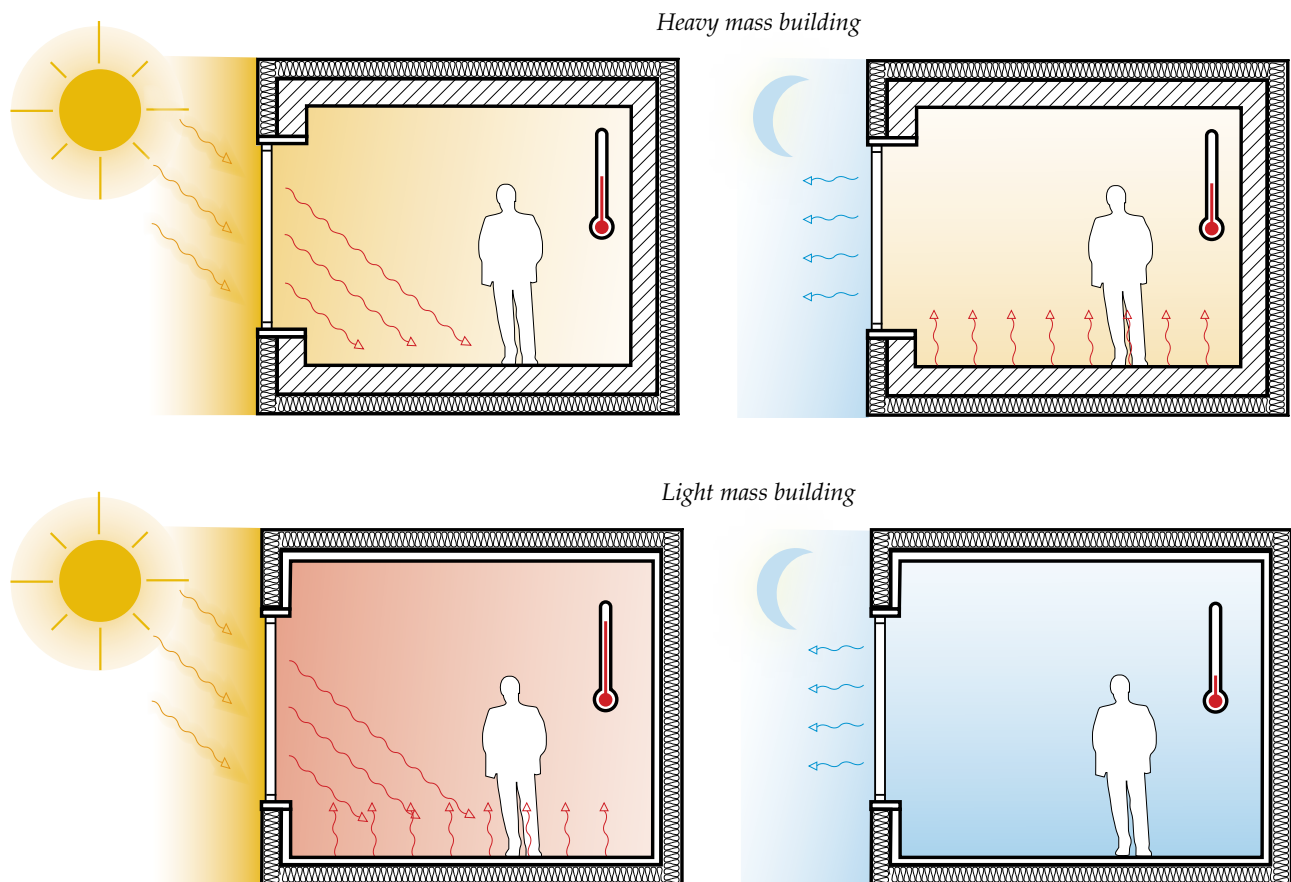

Thermal mass can have a negative impact on energy performance in some cases, where there is no opportunity to release heat into ambient air (in climates with no diurnal swing) or there is no opportunity for solar gains to be absorbed and stored (in climates with cold temperatures and low solar incidence).

#### 4.8.2 Benefits

- Reduced annual energy use.
- Reduced peak demand.
- Maintains a more stable internal environment.
- Increased acoustic insulation of assemblies.
- Improved fire ratings of assemblies.

#### 4.8.3 Limitations

- Without adequate direct solar radiation (i.e., on north-facing facades), thermal mass can result in increased energy consumption from the mechanical system when compared with lightweight construction.

#### 4.8.4 Synergies

- Passive solar heating.
- Passive ventilation.
- Passive cooling and shading.

#### 4.8.5 Vancouver Applications

- Thermal mass construction, when applied to the interior side of the insulation and exposed to the occupants and solar gains, will reduce heating energy requirements in the Vancouver climate.
- Thermal mass construction, when exposed to natural ventilation air flows and the occupants, will reduce cooling energy requirements in the Vancouver climate.
- Thermal mass can allow for natural, controlled moisture absorption and release in the Vancouver climate.

### 4.9 Thermal Insulation

#### 4.9.1 Overview

Thermally insulating materials are poor thermal conductors that slow the rate of heat losses and gains to and from the outside. Effective thermal insulation is one of the most critical design parameters of building envelope.

This reduction of heat transfer is expressed in terms of R-Value and U-Value. Minimum R-Values and maximum U-values for key building envelope components are prescribed by current ASHRAE 90.1 building energy standards.

Thermal insulation also impacts the surface temperature on the envelope interior, which directly

R-Value / U-Value
<p><b>R-Value:</b> <i>Thermal resistance</i></p> <p>How well the material slows down the transfer of thermal energy.</p>
<p><b>U-Value:</b> <i>Heat transfer rate</i></p> <p>The intensity of heat transfer through the material.</p>
<p><b><math>R \approx 1/U</math></b></p>

impacts thermal comfort. Interior envelope surface temperatures must remain high enough during winter to avoid condensation and maintain occupant comfort. Cold surface temperatures (i.e., windows) affect occupant comfort by both radiation and convection.

To achieve consistent thermal insulation of the building envelope, assemblies must be carefully detailed with continuous thermal breaks. Thermal breaks use non-conductive materials to separate conductive materials to avoid degrading the envelope's thermal insulation, a common problem called thermal bridging.

#### 4.9.2 Benefits

- Reduces heating and cooling losses/gains and energy consumption.
- More stable interior surface temperatures increases thermal stability in the conditioned spaces.

#### 4.9.3 Limitations

- Rate of diminishing returns, best investigated with building simulations.

#### 4.9.4 Synergies

- Infiltration and air tightness.
- Window performance.

#### 4.9.5 Vancouver Applications

- Thermal insulation must be better than the current standard (ASHRAE 90.1 v.2007) in order to maintain comfort with window to wall area ratios optimized for heating and cooling.
- Minimize thermal bridging to ensure the targeted overall R-values and U-values of envelope assemblies are achieved.

### 4.10 Air and Moisture Tightness

#### 4.10.1 Overview

The air and moisture tightness of a building's envelope is a critical factor in its thermal performance as well as its long-term durability. It is also indirectly related to the building's ventilation system.

Undesirable air movement through the envelope can occur in either direction: infiltration is movement of exterior air into the building, and exfiltration is leakage of interior air to the exterior. Infiltration and exfiltration can occur at the same time through different unintentional paths such as cracks around windows and doors, improperly sealed construction joints, or various services penetrating the envelope. They are caused by air pressure and temperature differences across the building envelope due to differences in air density between warm and cold air. Greater differences in pressure and temperature cause greater rates of infiltration and exfiltration.



Indoor air and outdoor air are not only different temperatures most of the time, but they also contain different amounts of moisture in the form of water vapour, which diffuses with the air. In the Vancouver climate this diffusion is predominantly from the warmer, more humid interior side (due to internal moisture gains) toward the cooler, less humid exterior side. If moisture is allowed to diffuse through the envelope, it will eventually reach the colder portion of the envelope assembly, where it will condense as the envelope temperature drops below the dew-point temperature (see Appendix C.2).

An incorrectly detailed building envelope with undesirable air and moisture diffusion typically has the following negative effects:

- Reduced thermal insulating value of the envelope resulting in excessive heat losses and increased heating energy requirements.
- Uncontrolled air and moisture exchange between the exterior and interior.
- Potential condensation within the envelope.

- Physical damage of the envelope components from condensation (e.g., corrosion of metals, rotting of wood).
- Potential occupant health impact associated with mildew and fungus growth resulting from the trapped moisture within the envelope.

To avoid these negative impacts, a building's envelope must be completely air- and moisture-tight. Depending on the envelope type, different approaches to achieve air and moisture tightness are required:

### 1. Lightweight envelope

For most conventional lightweight envelope assemblies (e.g., steel or wood frame), air and moisture tightness is best achieved by applying both a continuous vapour barrier on the interior side of the envelope, at or just behind the finished surface layer, and a continuous rain screen on the exterior face of the envelope with a narrow, vented air gap separating it from the insulation. This configuration keeps the moist air in the space and precipitation on the outside. (The interior moisture is removed by proper ventilation.) Provided the continuity of the vapour barrier and rain screen is achieved (by careful design and installation), the resulting envelope is completely air- and moisture-tight and thus avoids negative impacts such as the risk of condensation and reduced thermal insulation value.



**Figure 24: Air- and moisture-tight envelope (conventional, lightweight assembly)**

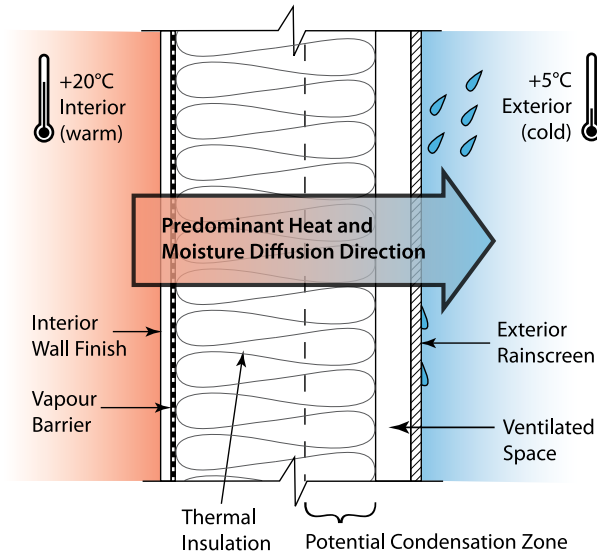

## 2. Heavy-weight envelope

High-performance heavy-weight envelopes should have “sandwich-like” assemblies with a relatively thick layer of concrete or masonry facing the interior and a layer of thermal insulation with a protective vented rain-screen facing the exterior. The dense and massive concrete or masonry layer is sufficiently air tight to keep infiltration and exfiltration at acceptable levels. Unless the interiors have consistently high humidity levels, as might be the case in a commercial kitchen, vapour barriers (e.g., waterproof coating, membrane, ceramic tile, etc.) on the interior surface may not be essential. As massive materials are also porous to a certain degree, they can absorb and release moisture from the indoor air. When combined with continuous exterior thermal insulation to keep the mass temperature above the dew point, the massive layer can absorb

and release moisture safely without risk of condensation and its related negative impacts. This continuous thermal insulation on the exterior side is critical to both improving energy performance and avoiding condensation. (Proper application of air and vapour barriers must be considered with a qualified building envelope consultant on a project-specific basis.)

Insulating heavy mass envelope from the inside requires a vapour barrier, since the potential condensation zone extends all the way to the insulation. Inside insulation also creates undesirable thermal bridges at floor-to-wall interfaces that are prone to condensation and compromise the thermal insulation value of the envelope.

Traditional non-tight envelopes had high infiltration/exfiltration rates (often more than 1 air change per

□ Buildings in Vancouver should have properly detailed and constructed air- and moisture-tight envelopes.

hour, or ACH) that were actually—and unintentionally—high enough to meet ventilation requirements. However, this undesirable, uncontrolled ventilation increased heating energy requirements and often caused condensation and its related negative impacts. Although in Vancouver’s mild climate the energy penalty for a non-tight envelope is not as severe as in the rest of Canada, uncontrolled air and moisture diffusion through the envelope is still undesirable. Properly designed and built air- and moisture-tight envelopes typically limit uncontrolled air exchange to less than 0.2 ACH. As a result, the space ventilation must be provided by separate means to provide sufficient fresh air for building occupants.

Space ventilation can be fully active with fans and heat recovery ventilation (HRV) units, fully passive with operable windows, or a mixed-mode system that combines the two. Most locations at Vancouver’s latitude have harsher climates with much greater heating-dominant requirements. In these climates, year-round reliance on fully active HRV is typically recommended as the most energy-efficient means of providing ventilation in air-tight buildings. However, in Vancouver’s milder climate, the most energy-efficient solution is the mixed-mode ventilation approach, relying on HRV during heating season only and relying on passive ventilation strategies for the rest of the year. (See Appendix E - Energy Modeling for modeling results that illustrate the greater efficiency of a mixed-mode system in the Vancouver climate.)

#### 4.10.2 Benefits

- A properly detailed and installed air- and moisture-tight envelope improves building energy performance and mitigates the risk of condensation and its related negative effects.

#### 4.10.3 Limitations

- Tighter envelopes require greater care to avoid leaks from face seals.
- An inadequately detailed and/or installed air- and moisture-tight envelope can result in cumulative moisture and condensation buildup within the envelope. This will result in compromised energy performance and other negative effects.

#### 4.10.4 Synergies

- Passive and mixed-mode ventilation strategies.
- Certain shading devices can also serve as additional rain protection for the envelope.

#### 4.10.5 Vancouver Applications

Buildings in Vancouver should have properly detailed and constructed air- and moisture-tight envelopes. Passively designed buildings should also incorporate a mixed-mode ventilation approach, relying on HRV during heating season only and relying on passive ventilation strategies for the rest of the year.

## Passive Design Tool Kit for Homes

# □ Passive Design Toolkit

## BEST PRACTICES FOR HOMES



**City of Vancouver  
Passive Design Toolkit - Best Practices for Homes**

**Prepared by Light House Sustainable Building Centre  
and Dr. Guido Wimmers.**

**November 2008**

**Cover photo: courtesy of melis+melis+wimmers**

# Contents

<b>1. Introduction.....</b>	<b>1</b>
How to use this toolkit:.....	1
<b>2. Passive Solar Power .....</b>	<b>3</b>
2.1 Solar Access .....	4
2.2 Energy Efficiency and Thermal Comfort .....	5
<b>3. Orientation .....</b>	<b>7</b>
3.1 Building Shape .....	7
3.2 Ideal Elevations.....	8
3.3 Landscaping.....	10
<b>4. Interior Layout.....</b>	<b>13</b>
4.1 Kitchens.....	13
4.2 Living Spaces.....	13
4.3 Bedrooms.....	13
4.4 Mechanical Systems .....	13
<b>5. Insulation .....</b>	<b>15</b>
5.1 Insulation Materials .....	16
5.2 Selecting Insulation Materials .....	22
5.3 Airtightness .....	23
5.4 Thermal Bridges.....	23
5.5 Assemblies.....	24
<b>6. Windows (glazing).....</b>	<b>25</b>
6.1 Thermal Quality and Style of Window .....	25
6.2 Location and Size of Windows .....	28
6.3 Shading .....	28
<b>7. Lighting.....</b>	<b>31</b>
7.1 Interior Layout and Windows.....	31
7.2 Skylights vs. Solar Tubes .....	31
7.3 Clerestory Windows .....	31
7.4 Paint as a Passive Lighting Strategy .....	33
<b>8. Ventilation.....</b>	<b>35</b>



**Contents Continued...**

8.1 Window Placement..... 35  
8.2 Stack Effect and Cross Ventilation..... 35  
8.3 Window Style..... 36  
8.4 Heat Recovery Ventilators..... 36

**9. Thermal Mass..... 39**

9.2 Slab on Grade Construction ..... 40

**10. Density ..... 43**

**11. Benefits of Passive Design ..... 45**

Summary & Recommendations..... 46

**Bibliography..... 48**

**i. City of Vancouver Policy Context ..... 51**

Green Homes Program..... 51  
Part 3 Buildings ..... 52  
EcoDensity..... 52  
Climate Neutral Network ..... 53

**ii. Acronyms and terms used in this report ..... 54**

# 1. Introduction

This toolkit outlines passive design best practices for low-rise wood framed construction buildings in Vancouver.

## How to use this toolkit:

This toolkit has been written to inform City staff and the design and development communities about passive design. While covering best practices, the toolkit addresses the specific needs of Vancouver and outlines a succinct definition of what 'passive' means for Vancouver. This toolkit can be used as a reference for best practices, and considered complementary to design guidelines and policy.

The principles of passive design are not new and are, in fact, based on simple, proven concepts. Passive design refers to an approach that discourages reliance on mechanical systems for heating, cooling and lighting and instead harnesses naturally occurring phenomenon such as the power of the sun, direction of wind and other climatic effects to maintain consistent indoor temperatures and occupant comfort. By leveraging the natural environment, buildings that incorporate passive design can:

- help to reduce or even eliminate utility bills
- improve the comfort and quality of the interior environment
- reduce GHG emissions associated with heating, cooling, mechanical ventilation and lighting
- reduce the need for mechanical systems, thereby reducing the resources required to manufacture



these systems, as well as the costs associated with their purchase or operation

- make alternative energy systems viable

Homes designed using passive strategies do not have to look aesthetically different from those that are designed without consideration for climatic factors, but occupants of a passive home will experience greater thermal comfort while paying lower energy bills. The most rigorous European standard, PassivHaus, regulates input energy to a maximum 15 kWh / m<sup>2</sup>/ year for heating/cooling/ventilation – about one tenth of that in a typical new 200 m<sup>2</sup> Canadian house, and a difference equivalent to 300 litres of oil, 300m<sup>3</sup> of natural gas or 3000 kWh of electricity annually.

□ Homes designed using passive strategies do not have to look aesthetically different



□ A passive design can reduce total energy demand for space heating and cooling to less than 15 kWh / m<sup>2</sup> / year.

When approaching the design for a building, the following questions can be considered:

*'How important is occupant comfort for this building?'*

*'How important is occupant health in this building?'*

*'How important is the environmental footprint of the building?'*

*'How future proofed is the building design?'*

*'How will the building make use of natural climatic factors?'*

Passiv Haus is a specific design standard developed in Austria and Germany. A building that qualifies for this standard has to meet clearly defined criteria, which include (for a building constructed at Northern European latitude of 40-60°):

- A total energy demand for space heating and cooling of less than 15 kWh / m<sup>2</sup> / year
- A total primary energy use for all appliances, domestic hot water and space heating and cooling of less than 120 kWh / m<sup>2</sup> / year
- The total primary energy use includes the efficiency of the energy generating system

A Passiv Haus building shares common core features with other passive design buildings, relying on four common strategies:

- A high level of insulation, with minimal thermal bridges
- A high level of utilization of solar and internal gain
- A high level of air tightness (See Chapters 5.3 and 5.4 for a discussion on Thermal Bridges and Air Tightness)
- Good indoor air quality (which may be provided by a whole house mechanical ventilation system with highly efficient heat recovery)

The Passiv Haus approach was used extensively as a reference in developing this toolkit.

For further information on the Passiv Haus system please visit [www.passiv.de](http://www.passiv.de)

## 2. Passive Solar Power

The sun emits energy as electromagnetic radiation 24 hours per day, 365 days per year, at a rate equivalent to the energy of a 5725°C furnace. In fact, each year the sun can supply nearly 36,000 times the amount of energy currently provided by total world oil consumption.



The sun's energy is radiated to the earth in the form of visible light, along with infrared and ultra-violet radiation which are not visible to the naked eye. When this radiation strikes the earth's surface, it is absorbed and transferred into heat energy at which point passive heating occurs. The rate at which solar energy reaches a unit area at the earth is called the 'solar irradiance' or 'insolation'.

Vancouver has a 'moderate oceanic' climate and is classified as heating dominated. This means

that buildings require more days of heating than cooling. Fortunately, Vancouver does not experience extreme heat or cold conditions for long durations, making passive design less challenging. Even though Vancouver receives plenty of sun in the summer, it receives very little sun from November to March and is challenged to benefit greatly from passive winter solar gain (unlike cold and sunny Edmonton winters). Winter also sees early sunsets and late sunrises, while in the height of summer Vancouver experiences long daylight hours (up to 16.5 hours).



□ **Fortunately, Vancouver does not experience extreme heat or cold conditions for long durations, making passive design less challenging in this city.**

**Table 1: Solar Radiation**

Climate: Vancouver  
Building: Kitsilano Residence

Interior Temperature: 20 C  
Treated Floor Area: 208 m<sup>2</sup>

	Jan	Feb	Mar	Apr	May	Jun	Jul	Aug	Sep	Oct	Nov	Dec	Year
Heating Degree Hours - Exterior (kKh)	13.9	11.1	10.8	8.3	6	3.7	2.5	2.6	4.8	8.2	10.9	13.3	96
Heating Degree Hours - Ground (kKh)	6.4	6.2	6.7	5.9	5.2	2.9	2.2	1.8	2.9	3.7	4.4	5.6	54
Losses - Exterior (kWh)	1413	1130	1095	846	615	380	255	263	487	837	1115	1350	9787
Losses - Ground (kWh)	180	173	189	166	145	82	62	51	82	102	125	157	1515
Sum Spec. Losses (kWh/m <sup>3</sup> )	7.7	6.3	6.2	4.9	3.7	2.2	1.5	1.5	2.7	4.5	6	7.2	54.3
Solar Gains - North (kWh)	30	53	87	118	171	197	186	140	95	64	38	23	1202
Solar Gains - East (kWh)	1	2	4	5	7	7	8	7	5	3	1	1	52
Solar Gains - South (kWh)	311	438	600	559	652	588	640	692	680	507	300	231	6199
Solar Gains - West (kWh)	2	4	6	8	12	12	13	11	8	5	2	2	86
Solar Gains - Horiz. (kWh)	0	0	0	0	0	0	0	0	0	0	0	0	0
Solar Gains - Opaque (kWh)	21	39	76	105	155	162	167	138	94	52	24	15	1047
Internal Heat Gains (kWh)	367	331	367	355	367	355	367	367	355	367	355	367	4318
Sum Spec. Gains Solar + Internal (kWh/m <sup>3</sup> )	3.5	4.2	5.5	5.5	6.6	6.4	6.6	6.5	5.9	4.8	3.5	3.1	62
Utilisation Factor (kWh)	100%	98%	92%	81%	55%	35%	23%	23%	46%	85%	99%	100%	63%
Annual Heat Demand (kWh)	863	453	234	77	6	0	0	0	1	94	526	871	3125
Spec. Heat Demand (kWh/m <sup>3</sup> )	4.1	2.2	1.1	0.4	0	0	0	0	0	0.5	2.5	4.2	15

A 150m<sup>2</sup> passively designed house (2 storey) would need 15 kWh/m<sup>2</sup>/year or less for heating. This is 150 m<sup>2</sup> x 15kWh = 2250 kWh in total per year for heating. The roof area of this home would be 75 m<sup>2</sup>. 75 m<sup>2</sup> x 0.78 (solar radiation) x 31 December days = 1800 kWh. Theoretically the energy from the sun given in December would be almost enough for the whole year!

### 2.1 Solar Access

Due to the low levels of solar exposure, passive design should include a combination of solar heating with passive cooling and shading in the Vancouver climate.

In consideration of Vancouver's climate, this toolkit will focus on maximizing solar gains in winter, and will include some recommendations for avoiding unwanted solar gain in the summer.

Solar access describes the amount of useful sunshine reaching a building. This value varies depending on climate, and can be impacted by the location of the sun and surfaces which surround a building.

The angle at which the sun strikes a location is represented by the terms *altitude* and *azimuth*. Altitude is the vertical angle in the sky (sometimes



referred to as the height); azimuth is the horizontal direction from which it comes (often referred to as the bearing). Altitude angles can vary from 0° (horizontal) to 90° (vertically overhead). Azimuth is generally measured clockwise from north so that due east is 90°, south 180° and west 270°.

### Altitude and Azimuth

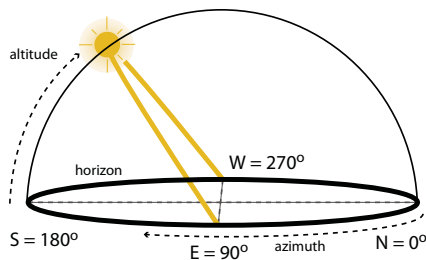

As solar radiation strikes the earth, it is reflected by surrounding surfaces. This is called reflected radiation. Light coloured surfaces reflect more than dark ones.

It is important to understand the pattern of the sun in relation to specific latitudes. A sun chart is the simplest way to determine where the sun is at specific dates and times throughout the year. In order to better determine solar access, there are also computer programs which can manipulate data from charts and formulas.

## 2.2 Energy Efficiency and Thermal Comfort

Though comfort can be highly subjective, The American Society of Heating Refrigeration and Air-Conditioning Engineers (ASHRAE) defines thermal comfort as the state of

mind that expresses satisfaction with the surrounding environment (ASHRAE Standard 55), and in this application, thermal comfort is achieved within a narrow range of conditions.

Factors such as temperature, ventilation, humidity and radiant energy affect thermal comfort, and for humans the comfort zone is within a very narrow range of conditions. Exterior climate conditions can also alter the acceptable interior conditions.

Building occupants are most comfortable when given the opportunity to adapt or have control over their environments (when they can open a window, put on a sweater, pull down the window blinds). Energy efficiency is achieved when occupant comfort is maintained through limited reliance on mechanical space conditioning. Thermal comfort rating software can model the amount of energy required to maintain comfortable temperatures within a building to size mechanical systems appropriately.

### Sun Chart

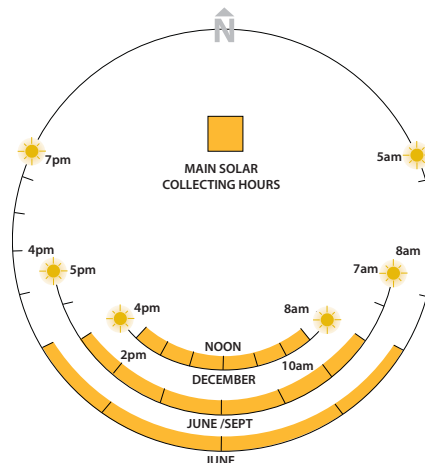

□ Solar access describes the amount of useful sunshine reaching a building.

### Dark and light surfaces

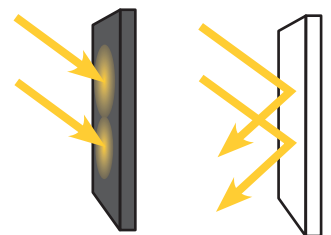

Light coloured surfaces reflect more than dark ones.





photo:melis+melis+wimmers

□ Energy efficiency is achieved when occupant comfort is maintained through limited reliance on mechanical space conditioning.

### Passive Solar Power

By planning for passive design, we can reduce the energy requirements of our built environment and improve thermal comfort for occupants. Passive design is not a new concept – ancient and medieval construction practices used abundant natural climatic conditions to passively control indoor temperatures.

#### Synergies/Barriers:

Designing for passive gains needs to be done keeping in mind best practices in construction – if a building is more air tight and leaks less energy, it must also be properly ventilated. If a building is to gain from south facing windows in the winter, it must also be shaded from the sun in the summer.

## 3. Orientation

Good building orientation in relation to the earth's axis and a site's geographical features can improve passive gains and thereby reduce the need for mechanical heating or cooling systems. This can also result in lower energy bills, and lower related GHG emissions.

Sites which are aligned along an east-west axis are ideal, as they receive good solar access while neighbouring houses provide protection from the eastern and western sun in the summer.

Broadly speaking, homeowners may have little or no control over optimizing site selection and orientation; the former depending on availability of property or land and the latter determined by municipal zoning. For instance, in Vancouver and many North American cities, a grid-oriented system predominates and in Vancouver the majority of homes are oriented north-south on east-west streets.

Still, small shifts in decisions around orientation, based on climatic and regional conditions, can help to optimize passive gains and maximize use of the free energy generated by the local environment.

### 3.1 Building Shape

To maximize the benefits of passive design, a design must first and foremost minimize overall energy consumption requirements. A building design which keeps corners and joints to a minimum reduces the possibility of creating thermal bridges through which heat can dissipate to the outside of a building (see discussion in Chapter 5.4, thermal bridges).

Inefficient layout

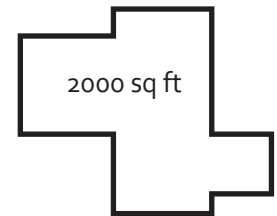

Efficient layout



Complex layouts lead to more corners and joints which leak energy. It also creates more surface areas which can lose heat

### Vancouver's Street Grid



□ In Vancouver the majority of homes (both house and condominiums) are oriented north-south on east-west streets.

Compactness is a measure of floor space relative to building envelope area. A compact design maximizes living space within a minimum envelope area. The envelope or shell of the building is where heat loss occurs. Restricting the number of exterior walls also ensures that the amount of wall exposed to the elements is kept to a minimum. In an ideal case, a building design will seek to maximize the ratio of usable floor area to the outside wall area (including the roof). The theoretical ideal form would be a sphere, because this is a maximized volume versus a minimum envelope. The next most usable form would be a cube, with every permutation from the ideal a step towards weakening the theoretical performance of the building.

Single family homes are usually not as high as they are wide or long. This varies from the ideal, thus major prominences and offsets should be avoided. These not only

increase the envelope surface, but also lead to creation of heat bridges and are harder to maintain. Rowhouses and townhouses are another form of design which achieve maximum floor area and minimize opportunities for heat loss.

- Utilize a compact design in order to minimize exterior wall surface area and associated heat gain/loss potential
- A shape as close to a square as possible is optimum to minimize corners and maximize floor area in relation to outside wall area

## Ideal Orientation

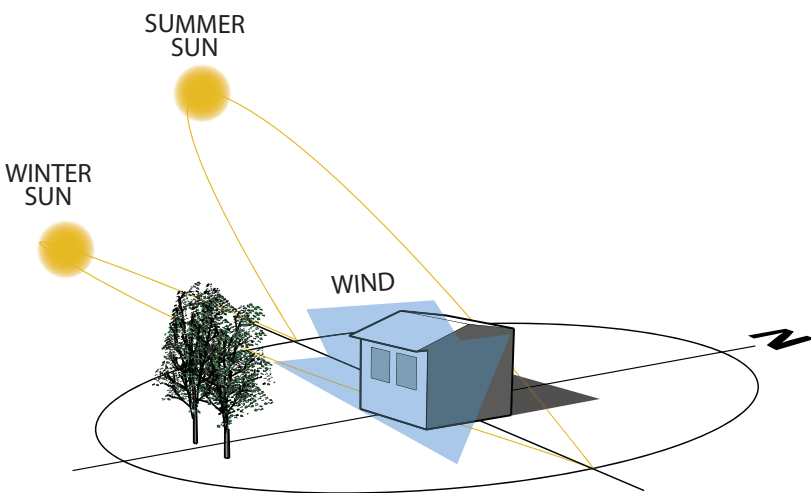

South facing windows allow for winter heat while strategically placed deciduous trees and overhangs will shade the hot summer sun. Neighbouring properties can effect solar access and wind pattern.

## 3.2 Ideal Elevations

Orientation can affect the angle at which the sun enters windows, causing overheating in the summer. Attention to overhangs can be useful when a building is poorly oriented. Building homes side by side and to the property line will also affect orientation considerations.

The angle of solar radiation as it enters a window (angle of incidence) will affect the degree of passive solar gain that radiation delivers.

When the sun is low in the sky, the light hits the window perpendicular to the glass. In this case, the heat gain is at a maximum. As the sun is higher in the sky, the angle is increased, reflecting more of the light. In this instance, less heat is transferred to the building. Windows on the south elevation can generally best exploit the sun.

## Southern elevation

To maximize the potential for solar gain through the winter months, a building should orient the longest elevation towards the south. (In design terms, south is considered to be anywhere within 30° east or west of true south.)

In addition, to reduce unwanted solar gain in the summer, designing for flexible sunscreens or overhangs for windows on these south facing elevations will ensure that the sun can be shaded during the warmer months.

Fixed overhangs should be designed to have a depth of roughly 50% of the height from the glass to the tip of the overhang. As the sun in summer is higher than in winter along the south elevation, a properly sized overhang can shade a south window for most of a summer day, without blocking out the low angled winter sun.

## Overhang

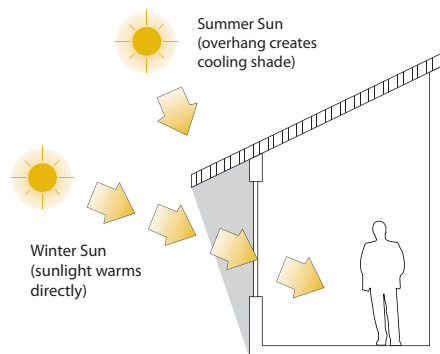

Because the winter sun is at a lower angle, sun can travel directly into the building warming it during the cool months. The high summer sun is blocked by the overhang creating a cooling shade.

- Maximize the window area on the south elevation
- Avoid winter shadows from coniferous trees, other buildings, or other obstacles that will create shadows during the short winter days

## Eastern and Western Elevations

To reduce unnecessary solar gain in the summer, a design should minimize window or wall area facing east or west.

Windows on the east elevation are exposed to solar gain throughout the year, while west facing windows will provide too much solar gain in the summer and insignificant gains in the winter.

At the same time, cold winter winds coming primarily from the east should also be taken into consideration.

- East facing windows should be limited in size, or protected by overhangs or trees
- West facing windows should be avoided unless they can be fully shaded during the summer months
- Planting deciduous trees on the east and west sides will shade the home in the summer, and allow winter light in when they drop their leaves
- The majority of residential lots in Vancouver are oriented such that the east and west facades are shaded by



□ A properly sized overhang can shade a south window for most of a summer day, without blocking out the low angled winter sun



□ Green roofs serve to moderate internal building temperature as well as to mitigate heat island effect. A study by the City of Toronto found that green roofs provide significant economic benefits in the areas of stormwater management and reduction of heat island (and the energy use associated with them). <http://www.toronto.ca/greenroofs/findings.htm>

**There are several types of green roof systems, and many do not use new technology. Any green roof should be installed and maintained with care, and it is highly critical that a structural analysis of the building be completed prior to installation.**



neighbouring houses.

- Landscaping with evergreen trees or tall hedges can help provide a windbreak

#### **Northern Elevation**

The north elevation provides the highest quality of daylight – diffused natural light.

- Design wall areas as primarily solid, with windows located where needed for daylighting and ventilation requirements
- Protect and insulate this elevation to prevent unwanted winter heat losses
- Take advantage of adjacent buildings to protect the building from heat losses

### **3.3 Landscaping**

Landscaping can aid passive design strategies

- Plant shade trees in the appropriate locations to block or filter harsh winds
- Vegetation that blocks winter sun should be pruned, deciduous trees should be planted as they shed their leaves in winter, allowing in the sun
- Balconies on the south, if designed incorrectly, can restrict access to the winter sun
- Deciduous vines in combination with overhangs can provide self adjusting shading. Vines on walls can also provide summer insulation but this strategy is complicated as vines can also compromise the building envelope
- Plants can be used instead of paving to mitigate heat island effect in the summer

### Key Design Strategies

- Orient the “main” side towards the south ± 30° East or West, and use large south-facing windows
- Keep east, north and west window space small, while also using fewer windows in total (see discussion under windows, chapter 6)
- Minimize unwanted shade to allow passive solar energy use
- Use landscaping consistent with required amounts of shading at different times of the year – deciduous trees will offer shade in summer but access to solar heat in winter
- Use a compact building form to limit heat loss
- Provide operable windows on all building elevations
- Row and multi-story building designs can maximize efficiencies



□ Deciduous trees provide cooling shade in the summer and, after shedding their leaves, allow for warm sun to enter the building in the winter

### Orientation:

Cost: \$\$\$\$

Ideal building orientation may be constrained by municipal planning layout requirements. A building can still use passive design strategies through careful consideration of the placement of windows and the design features used for shading and ventilation.

#### Synergies/Barriers:

As orientation is dictated by municipal planning, design becomes an important consideration – building design should acknowledge site limitations and compensate for them.

#### Impact on Energy Efficiency:

Even small changes in orientation and attention to details such as overhangs can be very effective.





photo:melis+melis+wimmers

## 4. Interior Layout

Good interior layout will facilitate many of the passive strategies recommended in this toolkit, in particular thermal mass, lighting and ventilation considerations.

Before deciding on interior layout, consider the following questions:

*Which are the most frequently used rooms?*

*What are the lighting needs for each room?*

*What is the external shading situation?*

### 4.1 Kitchens

Kitchens should ideally be located within the building in such a way as to avoid over-heating, either the kitchen itself or the rest of the building. One way to ensure this is to avoid placing kitchens on the western elevation. In most instances, this will cause over-heating in the warm summer months. An ideal location for a kitchen is on the eastern side of the building. This catches the morning sun but not the warmer, late afternoon sun. Northern elevations or central spaces within the building are also ideal for kitchens that are heavily used, though kitchens in central spaces need to ensure appropriate ventilation.

- Situate the kitchen on the eastern or northern elevation, or in a central space within the building

### 4.2 Living Spaces

Rooms that are occupied predominantly in the evening

should be located on the western side of the building, in order to take advantage of the evening sun. Frequently used rooms (such as a home office, or the living or dining rooms of a residential building), should be located on the southern side where they can be warmed by sunlight throughout the day.

- Situate evening-use rooms on the west elevation
- Situate frequent-use rooms on the south elevation

### 4.3 Bedrooms

Bedrooms generally require less heat. Decisions for the location of bedrooms can largely be based on aesthetics and occupant or designer preferences in addition to thermal comfort considerations. Ideally, windows should be kept to a minimum and should allow for passive ventilation (see discussion under Ventilation, Section 8).

- Situate bedrooms as comfort dictates

### 4.4 Mechanical Systems

Similar mechanical and plumbing equipment should be grouped within close proximity of each other. This minimizes inefficiencies in piping or heat loss due to unnecessarily long lines and also



□ Rooms that are occupied predominantly in the evening should be located on the western side of the building, in order to take advantage of the evening sun.



Temperature sensors should not be situated in the northern part of a building. This area is generally cooler and sensors may detect cold even though the southern part of the building is receiving solar gain. A good passive design strategy would be to attempt to distribute this heat to the cooler parts of the house (see Chapter 9).

economizes on space dedicated to mechanical uses.

Bathrooms, kitchens and laundry rooms should be placed above or adjacent to each other, so that efficiencies of the plumbing system can be maximized.

Minimize the building footprint by using short pipe runs (hot/cold water or sewage) and ventilation ducts

Place thermostats with due consideration to temperature variances within the building (see sidebar)

### Ideal Floor Plan

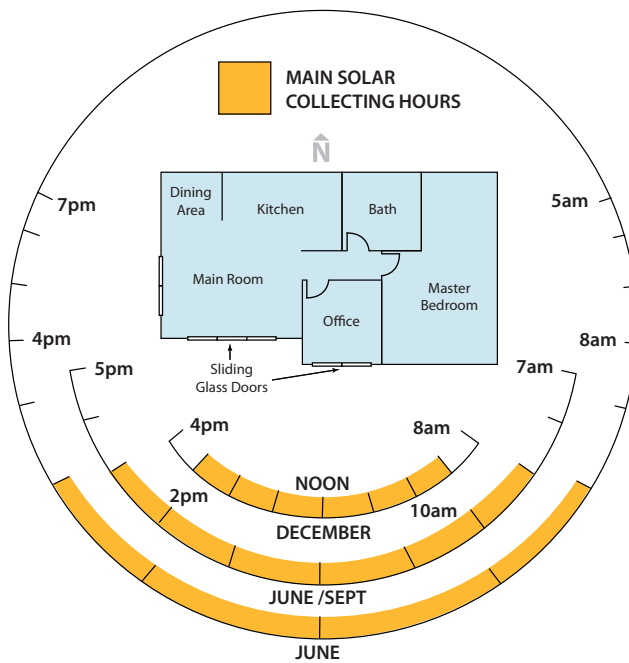

#### Interior Layout:

Cost: \$\$\$\$\$ - \$\$\$\$\$

Good interior layout can assist greatly with passive heating and cooling, with particular opportunities for efficient daylighting.

#### Synergies/Barriers:

Layout decisions should incorporate other building elements and work in harmony with them, such as the windows and mechanical systems.

#### Impact on Energy Efficiency:

Good interior layout can off-set later energy consumption by reducing need for light and heat.

## 5. Insulation

In the world of outdoor clothing, breathable fabrics and super insulated linings work with highly detailed seams and closures to keep out wind, water and cold. Sound building envelope design can similarly moderate these conditions.

Minimum insulation requirements are currently embedded in the BC Building Code as well as the City of Vancouver Building By-laws. These can be prescriptive in nature (e.g. 'install R12 insulation'). However, the City of Vancouver and the new provincial building code are moving towards a performance, rather than prescriptive, path. Beyond a certain thickness, there is minimal increase in performance and attention must be paid to the airtightness of the construction. The performance path, which measures the overall energy performance of a construction, is a more accurate way to ensure that a building performs as intended.

For example, the EnerGuide rating system uses a blower door test to measure airtightness. Energy modeling, such as with EE4 software available from Natural Resources Canada, can predict the energy usage of a building. These approaches are more likely to ensure a particular level of performance, rather than specifying insulation values without then confirming that installation of specific insulation is actually delivering better performance.

Appropriate insulation can mitigate heat loss (or gain), while also eliminating the uncomfortable effects of unwanted radiant energy from warm surfaces in summer or cold surfaces in winter. To do this effectively, envelope design should be climate appropriate.

Insulation is arguably the most critical determinant of energy savings and interior thermal comfort, though good insulation should not preclude consideration of air tightness, heat bridges and appropriate windows. An increase in the number of windows or doors decreases a building's performance

(see discussion under Chapter 6, Windows).

Among the questions to be asking when making insulation decisions and selecting materials are:

*What is climate-appropriate insulation for this building?*

*What are the environmental considerations of the material selected?*

*Are there other benefits of the material besides insulation?*

*How will the design of the building be airtight?*

### Heat Loss

Insulated

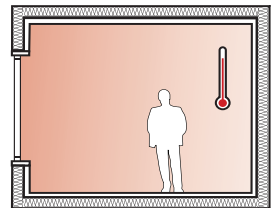

No Insulation

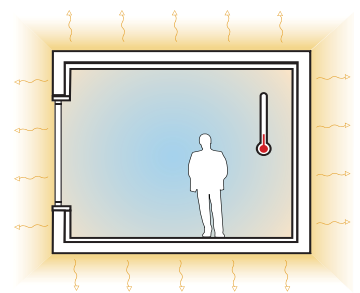

Heat exits a non-insulated building quickly thus requiring more heating resources to keep a room comfortable.





□ Insulation materials can be categorized into organic or inorganic, renewable or non-renewable, or they can be listed by consistency, such as foam or rigid, wool or loose.

### Thermal Resistance

The thermal resistances of insulation materials will contribute to indoor surface temperatures of a building's exterior walls and thereby the internal thermal comfort. High thermal resistance indicates good insulating qualities. Resistance is in turn influenced by the temperature difference between inside and outside, the conductivity of the insulation used, and the thickness of this material.

Temperature difference is an external factor, while thickness and conductivity are determined by the choice of insulation material. Lower conductivity and greater thickness both reduce heat flow.

R-values are a measure of a material's resistance to heat flow, and are therefore an indicator of a material's insulation properties. On the other hand, U-values are a measure of the amount of heat that escapes a surface. In the case of windows, the glass does not act as an insulation material, and therefore measurement of R-value is not appropriate, and we use U-values instead.

$$R=1/U$$

The higher the R-value, the better insulation qualities displayed by the material. The lower the U-value, the better performance of a window against allowing heat or cold to pass through it.

## 5.1 Insulation Materials

Over the lifespan of a building, insulation will always have a positive environmental impact by reducing operating energy. However, the ecological footprint of the material itself should also be taken into consideration. This is complicated to define because there are a lot of different factors to be considered. Insulation can also have a bearing on indoor environmental quality depending on the materials selected, and can have implications for airtightness.

Classification of insulation is not straightforward as there are several systems to differentiate between materials. Materials can be categorized as organic or inorganic; renewable or non-renewable; or they can be listed by consistency, such as foam, rigid, wool or loose.

### Examples of insulating materials (all available locally):

#### *Conventional Insulating Materials*

##### *Fibreglass*

Fibreglass in one of its two forms (loose or batts), remains the industry standard in North America. Most fibreglass insulation now contains some recycled content, and some manufacturers have replaced the traditional-but-toxic phenol formaldehyde binder with other more benign alternatives – or no binder is used at all.

Loose fill, a type of fibreglass insulation which is small and fluffy and blown into place, is associated with black mould and health hazards similar to those associated with asbestos such as lung disease. On the other hand, fibreglass

batts are considered to have little or no negative impact on indoor environmental quality.

### *Spray applied foam*



Sprayed foam insulation is used in some higher performance residential buildings. It allows for continuity of insulation as insulation is sprayed when in liquid form, and then expands to fill the cavity – including the smallest cracks. Performance is not as prone to installation errors.

Products range from those with a high content of toxic substances, to those that are water-blown and do not off gas.

### *Rigid Polystyrene*

This product displays fairly high R-Values (RSI-Values) and is durable as well as relatively affordable.

There are, however, issues with CFC's and other hazardous substances that go into the production of polystyrene panels. Furthermore, this material is a derivative of crude oil, and therefore displays a large carbon footprint.

Some polystyrene products do not off-gas, and of the two main types of rigid polystyrene (extruded or XPS, and expanded or EPS) EPS is the more environmentally benign.

### *Aerogels*



Aerogels are a form of frozen silica smoke with extremely small pores, making this material extremely durable and light with incredible insulation values. Many are also translucent – and can be used to insulate windows and skylights or create translucent walls.

However, this is a very new material and testing is indicating that silica foam has similar detrimental health effects to fiberglass and asbestos; microscopic particles can break off and lodge in skin or lungs. Use of aerogels is not very common.

### *Mineral Wool*

In industrial and commercial construction, mineral wool remains popular for its fire resistance, though extraction and processing of mineral wool (a by product of steel processing) may still be an environmental concern.



□ Many aerogels are translucent – and can be used to insulate windows and skylights or create translucent walls.



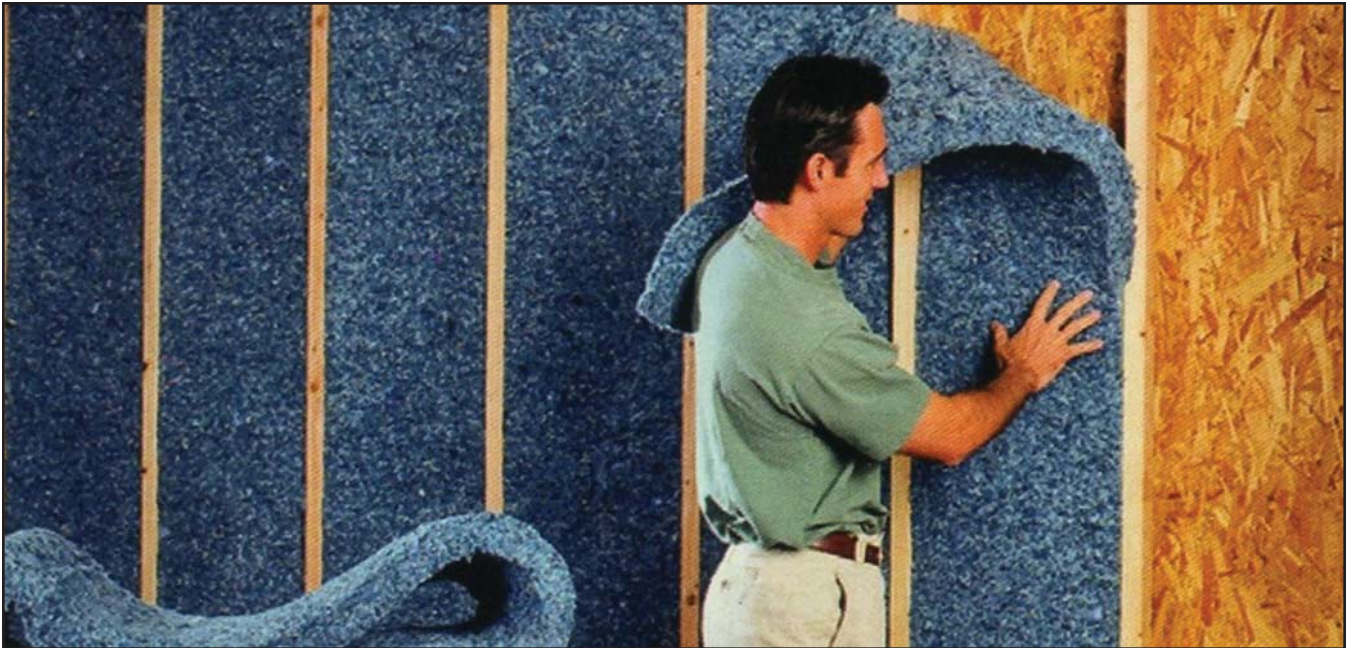

□ **Natural cotton insulation made from recycled or waste denim**

***Natural Insulating Materials***

*Cellulose fibre*

Among commercially available natural materials, cellulose fibre (usually recycled newsprint), is gaining popularity.

Spray applied cellulose fibre is quite dense and provides a good barrier against air infiltration from the outside. Due to the spray in nature of the installation, performance is less likely to suffer from installation errors.

*Cotton insulation*

Cotton insulation made from recycled or waste denim is easy to install and does not off-gas.

*Sheep's wool*

Wool has been made into warm clothing for centuries but only now

is its excellent insulating quality being applied to building structures.

*Wood fibre*

Waste wood fibre panels, of varying densities, are a popular insulation material for PassivHaus buildings in Europe. With a small ecological footprint this material also provides sound reduction and high thermal mass.

*Straw bales, hemp or flax*

First used to construct homes by settlers of Nebraska in the late 1800s, straw bale homes offer an insulation value of more than double that of standard frame homes. It's considered a very environmentally friendly building form, as it comes from a quickly renewable source and reduces the need for framing lumber and plastic barriers.

Table 2 – Insulation Comparison Chart

Insulation Material	Common Application	Environmental Impact	IAQ impact	Typical R Value per inch	Other Considerations	Cost Effectiveness (\$-\$-\$-\$-\$)
Fibreglass Batt	Typically between floor or ceiling joists or wall studs	Some brands have up to 40% recycled content and have eliminated use of toxic binders, i.e. Formaldehyde-free Made from material with abundant supply	If non-toxic binders used then harmless. Respirator or certified dust mask to protect the lungs and long sleeve garments and gloves to protect the skin should be worn when working with fibreglass	3.6	Low moisture absorption Fire resistant with low flame spread rating (non-faced only) Does not absorb or retain moisture Little or no settling Ease on installation (placement and cutting for irregular spaces) Does not attract insects Insulation value decreases when wet	\$
Fibreglass blown or poured	Typically between floor or ceiling joists (horizontally) where there will be no traffic (i.e. attic), can be used in wall studs (vertically) but installation may be restricted due to wall blocking, nails, cables, etc. In horizontal applications it is excellent at leaving no gaps.  Will require small holes to be blown into wall cavities	Some brands have up to 25% recycled content and have eliminated use of toxic binders, i.e. Formaldehyde-free	If non-toxic binders used then harmless. Respirator or certified dust mask to protect the lungs and long sleeve garments and gloves to protect the skin should be worn when working with fibreglass	2.9	Low moisture absorption Fire resistant with low flame spread rating Does not absorb or retain moisture Little or no settling Better insulation coverage when dealing with irregular spaces, ceiling protrusions, hard to reach spaces, etc. as it creates a blanket over everything Requires a professional to install Must ensure it does not block attic venting when blown in	\$\$
Spray Polyurethane Foam	Can be used anywhere insulation is required, vertically or horizontally. Very good for situations where batt or board insulation is hard to attach, i.e. floor rim joists, lintels, etc. Can also be applied just as a base layer and then topped with batt insulation to save costs	Contains a minimum of 5% recycled content Can be up to 33% soy-based HCFC blowing agents replaced with HFCs, carbon dioxide or water and do not harm the ozone layer Can create a fair amount of waste (face shavings in stud cavity) Not recyclable	Once the spray has cured (generally after 24 hours) the components are inert and do not effect IAQ	7	No settling Can be used as an air barrier but not a vapour barrier Can fill and seal tiny cracks Not attractive to insects Mixed and installed on-site by a professional Must be protected from prolonged UV exposure to sunlight Requires covering with a fire resistant material when used indoors	\$\$\$\$
XPS (extruded) Polystyrene Board	Confined spaces like basements, foundation slabs, crawli spaces or exterior walls. Must be tight fit to avoid gaps	May contain some recycled content and can be recycled itself. Uses HCFC as blowing agent Made from petrol chemicals Recyclable	Brominated flame retardants present a greater health concern than the nonbrominated flame retardants used in polyisocyanurate, spray polyurethane, and cellulose insulation.	4.7 - 5.0	Moisture resistant and suitable for below grade applications Must be protected from prolonged exposure to UV or solvents If joints are sealed can act as an air barrier With increasing thicknesses can act as a vapour barrier When installed on an interior surface must be covered with a fire resistant material mechanically fastened to the building structure	\$\$\$

Insulation Material	Common Application	Environmental Impact	IAQ impact	Typical R Value per inch	Other Considerations	Cost Effectiveness (\$-\$-\$-\$-\$)
EPS (expanded) Polystyrene Board	Confined spaces like basements, crawl spaces or exterior walls. If below grade must be coated with foil or plastic. Must be tight fit to avoid gaps	May contain some recycled content and can be recycled itself. Made from petrol-chemicals	Brominated flame retardants present a greater health concern than the nonbrominated flame retardants used in polyisocyanurate, spray polyurethane, and cellulose insulation.	3.7 - 4.0	Moisture resistant and suitable for below grade applications Must be protected from prolonged exposure to UV or some solvents If joints are sealed can act as an air barrier With increasing thicknesses can act as a vapour barrier When installed on an interior surface must be covered with a firer resistant material mechanically fastened to the building structure	\$\$\$
Aerogel	Not yet ready for commercial use	This technology is still early in the production stage so comprehensive analysis of effects is not yet available. Some research is going into use of discarded corn husks for aerogel manufacture.	Aerogel dust can generate dry skin, eye irritation and respiratory interactions.	> 140	Light weight High compressive strength	\$\$\$\$\$
Polyurethane and Polyisocyanurate Board	Confined spaces like basements, foundation slabs, crawl spaces or exterior walls. Must be tight fit to avoid gaps Good for locations where a high R-value is required in a small thickness	Some brands use soy-based foams made from renewable vegetable oils and recycled plastics Can have some recycled content. Most brands no longer use formaldehyde or HCFC as the blowing agent Not recyclable Made from petrol chemicals	Boards are cured and the components are inert and do not effect IAQ	5.8 - 7.2	Usually come double faced with foil and sometimes bonded with an interior or exterior finishing material Foil face acts as a radiant heat barrier adding about R 2 to the insulation assembly Must be protected from prolonged exposure to UV or water If joints are sealed can act as an air barrier Can act as a vapour barrier Must be covered with a fire-resistant material	\$\$\$
Mineral Wool (Slag and Rock Wool)	Attics, wood-framed roofs, walls, floors and around chimneys	Made from natural basalt or volcanic rock and slag (a by-product, containing inert materials, produced during the blast furnace smelting process and other steel making operations, therefore post-industrial recycled waste up to 70%) When properly installed can save up to 1000 times the amount of energy used to produce it Product is recyclable Energy intensive to produce but less per R value than fibreglass	Scientific research shows material is safe to manufacture, install and use when following manufacturers instructions. Once installed no significant fibres are released. Can be CFC and HCFC free Mineral wool may contain up to 5 % phenol-formaldehyde by weight—more than most fibreglass insulations.	3.1	Non-combustible and can withstand temperatures up to 1000 °C Repels moisture Excellent acoustics barrier Ease of installation (placement and cutting for irregular spaces)	\$\$
Cellulose Fibre (blown or poured)	Typically between floor or ceiling joists (horizontally), can be used in wall studs (vertically) but installation may be restricted due to wall blocking, nails, cables, etc. Not to be used below grade Will require small holes to be blown into wall cavities	Up to 80% recycled paper, 20% fire retardant chemicals Requires up to 30 times less energy to make than fibreglass or mineral wool insulation	Inhalation of dust during installation VOC emissions from printing inks (although an increasing number of newsprint are using vegetable based inks) Allergic reactions may occur from inks	3.6	Requires professional installation VOIDS unlikely with careful installer Absorbs moisture which may lead to fungal growth Combustible as fire retardant may not be consistent and may deteriorate over time Can settle up to 20% over time	\$\$

Insulation Material	Common Application	Environmental Impact	IAQ Impact	Typical R Value per inch	Other Considerations	Cost Effectiveness (\$-\$-\$-\$-\$)
<b>Cotton Batt</b>	Typically between floor or ceiling joists or wall studs	Cotton is a natural, renewable resource but the crop is water intensive, and can involve the use of pesticides or fertilizers which contribute to soil erosion. Some sources include scrap denim generated during denim manufacturing giving it a high recycled content. (70%+) Low energy consumption in manufacturing process. Product can be recycled	No formaldehyde-based binders. Safe to handle	3.6	Fire resistant with low flame spread rating. Little or no ceiling. Ease on installation (placement and cutting for irregular spaces). Good performance at low temperatures. Will absorb moisture.	\$\$
<b>Sheep's Wool</b>	Typically between floor or ceiling joists or wall studs	Wool is a natural renewable resource that is treated with a natural rubber and borax solution for forming into rolls. Borax is a naturally occurring non-volatile salt that is used for its pest-repellent, fire-retarding, and material preservation qualities. A natural latex rubber is used to allow borax to be applied to each fibre and increases the memory effect of the wool so that it will expand back to its natural shape after being compressed during installation.	Borax is practically non toxic to birds, fish, aquatic invertebrates, and relatively non toxic to beneficial insects.	3.8	Good sound absorption. Natural buffering effect helps regulate indoor temperatures. Retains thickness reducing insulation efficiency overtime. Wool is also a natural fire retardant, safe to handle, renewable and recyclable.	\$\$
<b>Wood Fibre Boards</b>	Suitable for internal use as thermal and acoustic insulation on floors, walls and ceilings. They can also be used as external insulation with render protection and can receive lime and earth based clays band renders.	Wood fibre boards are rigid building boards made from sawmill off cuts that are pulped, soaked and formed into boards. The boards are then heated and compressed to their final thickness. Paraffin wax may be used as the binding agent.	Boards do not contain and glue or wood preservers. Non toxic in manufacture, use and waste disposal	3.8	99.5% waste material, off cuts from sawmill mainly. Very good breathability including hygroscopic moisture control to prevent moulds and improve indoor air quality. Uses about 1/10th the energy per tonne of product compared to plastic insulation boards. Wood fibre board insulation provides thermal mass to help regulate interior temperatures.	\$\$\$
<b>Straw Bales</b>	Used as infill in wall assemblies in post and beam construction or as a load bearing wall assembly. Straw bales are typically 18 or 24 inches wide, depending upon stack orientation.	Any type of straw can be used, wheats, oats, barley, etc. The bales are made from the agriculture waste of the harvest, which is annually renewable and in many parts of the world is typically burned in the field.	Straw bales are a non-toxic product that allows a gradual transfer of air through the wall, bringing fresh air into your living environment, especially when combined with a natural plaster. Most straw bale houses do not incorporate vapour, air or moisture barriers as they want the natural breathability of the wall which further reduces the number of man made chemicals impacting the indoor air quality.	2.7	Excellent fire resistance qualities, a plastered straw bale wall will easily pass a two-hour fire test. Straw bales houses have stood the test of time, some being older than 100 years. Excellent sound absorption and ease of building can reduce construction costs. Requires large overhangs for moisture protection in rainy climates	\$\$



## 5.2 Selecting Insulation Materials

Insulation can serve as more than just an energy barrier, providing fire resistance, humidity control, and noise reduction among other things. Many fibre-based materials, such as cellulose or wood fibre, are sensitive to water exposure – a common concern in Vancouver’s climate. On the other hand, these materials can also act to modify humidity levels, which is particularly relevant for structures which are meant to breathe, such as those which use straw bales.

- Select materials by balancing their relative strengths and weaknesses against environmental impact considerations. Table 2 provides a comparison of common insulation materials and their applications.

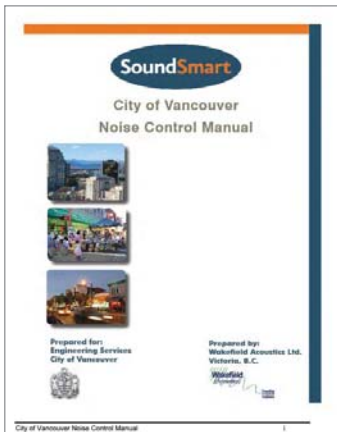

□ **The City of Vancouver Sound Smart Manual can be found at [www.city.vancouver.bc.ca/engsvcs/projects/soundsmart/pdfs/NCM1.pdf](http://www.city.vancouver.bc.ca/engsvcs/projects/soundsmart/pdfs/NCM1.pdf). This document contains detailed information on sound control and the use of building materials and orientation to mitigate noise pollution.**

### Fire Resistance

The combustibility of insulation materials is also an important consideration, although deaths in fire situations are more commonly caused by the inhalation of smoke generated by combustion of the room contents rather than the building envelope materials. Products like rock wool or even cellulose and wood fibre perform better in fire situations than polyurethane or polystyrene based foams or fiberglass.

Another potential problem is the chimney effect caused by shrinking of insulation materials within the wall cavities. Gaps of 19mm or greater can lead to a convection loop, allowing flames to spread more quickly from storey to storey.

### Noise Reduction

Noise reduction can be a valuable indirect benefit of thermal insulation. There are two characteristics materials need to display in order to have a positive influence on noise reduction: high mass and flexibility. Polystyrene or polyurethane, for example, display neither and therefore have nearly no influence on noise. Rock wool, fiberglass and cellulose fibres are soft and have a significant mass, so they can make a contribution to noise reduction. The densest insulating material is wood wool, which is a very efficient sound deadener.

### Specific Heat Capacity

This term is used to compare the heat storage capacity per unit weight of different materials. Unlike thermal mass, heat capacity is not linearly related to weight; instead it quantifies the heat storage capacity of a building element or structure, rather than its ability to absorb and transmit that heat.

The thermal mass of a material or assembly is a combination of three properties:

- Specific heat
- Density
- Thermal conductivity

### 5.3 Airtightness

It is imperative for a structure to have an airtight layer in order for insulation to be effective. There are several strategies for achieving a super tight building envelope.

#### Air Barriers

Up to 25 percent of the energy loss in a building is attributable to air leakage. This can be addressed quite easily in new construction with careful attention to draught sealing, as well as carefully designed air locks (such as double doors). Poor airtightness can also contribute to mould problems if warm humid air is allowed to seep into the structure. Renovations are more complicated, though an airtight layer has to be added to the existing structure.

#### Moisture Barrier

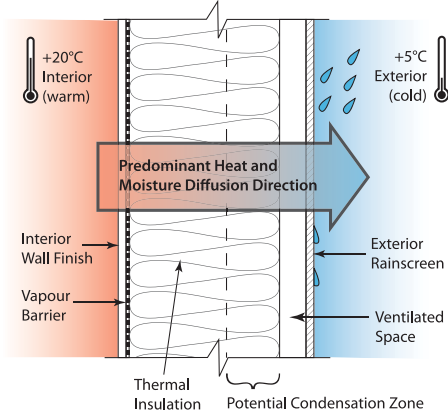

An air barrier system should be continuous around all components of the building, with special attention given to walls, roof and the lowest floor. There must be proper continuity at intersections, such as the connection between floors, the joints between walls and

windows or doors, and the joint between walls and the roof.

External house wrap, polyethylene and airtight drywall are probably the most common techniques for creating an air barrier. Correct sealants and caulking can help to stop leaks and must be properly installed to ensure durability over time.

#### Vapour barriers

Vapour pressure is generally higher inside a building due to the moisture generated by the occupants and their activities. This will create an external flow of vapour towards the outside, where the pressure is lower. If the vapour is allowed to move through the assembly it can condense on the surface leading to dampness and ultimately to mould or rot.

A vapour barrier reduces the movement of the vapour through the building assembly so that condensation does not occur. There are several types of vapour retardants including polyethylene, foil or latex paint. Unlike an air barrier the continuity of the vapour barrier is not as crucial as it can still perform well even if gaps are present.

### 5.4 Thermal Bridges

A thermal bridge occurs where construction materials create a bridge between internal and external environments allowing a heat transfer to occur. Metal is highly conductive and therefore susceptible to thermal bridges but any material can contribute to this effect to some



□ Up to 25 percent of the energy loss in a building is attributable to air leakage.



□ Energy modeling software

**EE4:** Software to assess the energy performance of your design and verify design compliance against the Model National Energy Code for Buildings (MNECB). Available from Natural Resources Canada at [http://www.sbc.nrcan.gc.ca/software\\_and\\_tools/ee4\\_soft\\_e.asp](http://www.sbc.nrcan.gc.ca/software_and_tools/ee4_soft_e.asp).

**Hot2000:** A low rise residential energy analysis and design software available from Natural Resources Canada at [http://www.sbc.nrcan.gc.ca/software\\_and\\_tools/hot2000\\_e.asp](http://www.sbc.nrcan.gc.ca/software_and_tools/hot2000_e.asp).

**RETScreen:** Evaluates the energy production and savings, costs, emission reductions, financial viability and risk for various Renewable Energy and Energy Efficient Technologies (RETs). Available from Natural Resources Canada at <http://www.retscreen.net/ang/home.php>.

degree. Wherever possible, thermal bridges need to be avoided through the use of a thermal break.

Thermal breaks are literally breaks inserted into the component (for instance in the window frame), which separate the exterior and interior materials.

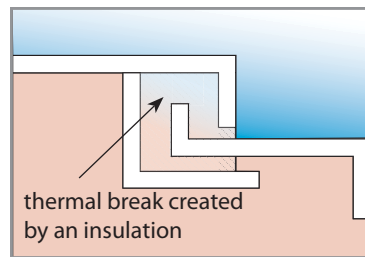

## 5.5 Assemblies

Cavity walls

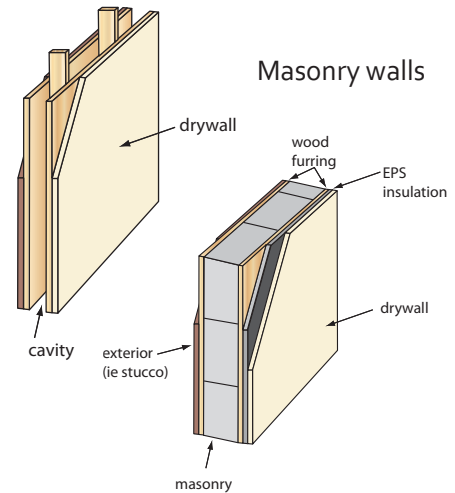

### Insulation:

Cost: \$\$\$\$ - \$\$\$\$\$

Insulation is one of the most critical elements in reducing energy consumption requirements by avoiding unnecessary loss of thermal energy. The choice of material can also have non-energy related positive impacts.

### Synergies/Barriers:

- When making decisions regarding insulation one should consider the whole building as a system and account for airtightness and vapour protection.
- Energy modeling, for instance using HOT2000 software can help to determine when increasing insulation in a certain part of the building will improve performance and when it can no longer make a difference.
- It is important to remember that the main source of heat loss is through the windows, so it is essential to install high performance frames and to reduce thermal bridges in these areas.

### Impact on Energy Efficiency:

Insulation lowers the need for heating and cooling, reducing overall energy consumption.

## 6. Windows (Glazing)

One of the most efficient ways to harness the power of the sun is through the use of suitable window technologies. Conventional residential buildings lose upwards of 50 percent of their heat through windows. At the same time, passive solar gain through windows is generally limited to just a few percent. In order to design windows that contribute to passive heating in the cooler winter months without an associated overheating risk in the summer, it is critical to balance location, size and thermal quality.



photo:melis+melis+wimmers

When making window decisions, consider the following:

*How does window design address daylighting, views, ventilation?*

*How much heat loss will be attributable to the windows?*

*What is the payback for investing in high performance systems?*

*Are there other design considerations? (Overhangs, landscaping etc.)*

### 6.1 Thermal Quality and Style of Window

The overall quality of a window is key to its performance and can be determined by the thermal quality of the glass and the frame. Further considerations are the solar heat gain coefficient of the glass and of the spacer material.

The style of window will also have an effect on its performance. Slider windows may be poorer air barriers as the sealing system is harder to design. Fixed windows are permanently sealed but do not offer the benefits of ventilation, while hinged windows use compression seals that, while more sturdy than slider windows may still wear out. Seals may wear out and not be replaced.

### Heat gain / heat loss

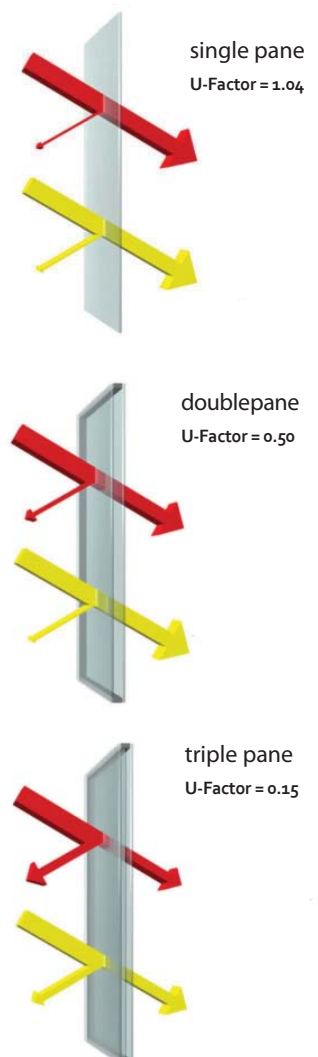

**What is a U Value?**

U-value is measured by  $U = 1/R$

U-values for windows can refer to the centre of glass or edge of window 'whole frame' measurements.

The value will change with the size of the window because the ratio of window to frame will increase as the window gets bigger.

Most manufacturers provide the U value of the glass and the frame separately – proper analysis must assess the U value of the entire system.

**Table 3**  
**Thermal Quality of Glass**

<p><b>Low-e windows:</b> Double pane glass with a U-value ranging from 1.1-1.5 W/m<sup>2</sup>K and a solar heat gain coefficient of approximately 60%.</p>	<p>This type of window is more or less energy neutral when placed on the southerly side of a building, meaning solar gain is approximately the same as solar loss. If placed in any other location, this type of glass loses more energy than it gains. Therefore, it is recommended to avoid low-e windows when working with passive design especially in Vancouver which gets less than 2.5 hours of sun per day during the winter.</p>
<p><b>Super high performance windows:</b> Triple pane glass with a U-value ranging from 0.5-0.7 W/m<sup>2</sup>K and a solar heat gain coefficient of 50-60%.</p>	<p>When used in cooperation with a super-insulated frame, these windows can facilitate solar heat gain. During cold or overcast days, or overnight, a window using this type of glass will lose less energy than it can capture during sunnier periods. Increasing the proportion of glass of this quality on the southerly side will encourage more passive solar gain.</p>

A precondition for the glass to deliver the performance as per table 4, is a super-insulated frame. Installing high performance triple pane glass into a common frame would be inefficient. Even using this combination, the frame is the weakest link delivering nearly no solar gain while also creating thermal

bridges. In other words, windows are always a source of energy loss.



**Table 4 – Thermal Quality of Frame**

<b>Common wood or vinyl frame</b>	Generally has a U-value between 2.0-2.5 W/m <sup>2</sup> K. These are the most commonly used.
<b>Metal or aluminium frames</b>	Though strong, these materials have high heat conductivity – aluminium can decrease the insulating value of a window by 20 to 30 percent. These frames, combined with triple pane windows, would reach a maximum U-value of 1.6-2.0 W/m <sup>2</sup> K even if thermal breaks were inserted in the design. See Chapter 5 for discussion on thermal breaks.
<b>Timber frames</b>	Good insulator but requires more maintenance than aluminium. Wood used in their manufacture should be sourced from a sustainable forest (see FSC certification).
<b>Composite frames</b>	Aluminium outer sections with either a timber or uPVC inner section.
<b>Super insulated frames</b>	May consist of wood or a wood/metal composite window frame which is hollowed out and filled in with foam or some other form of insulation. These types of frame may reach U-values of under 0.8 W/m <sup>2</sup> K – a good fit for 0.7 or better windows.

- Use a super high performance window and frame to mitigate the amount of energy lost through windows.
- Select window styles with durable seals.
- Keep in mind that this strategy is important, as nearly half of the energy loss of a home is associated with windows.

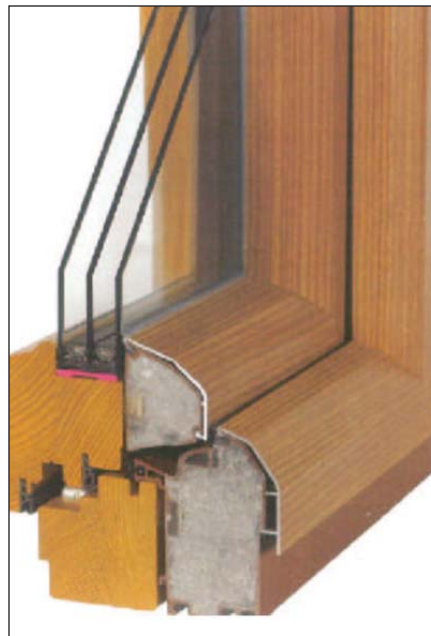

□ Super high performance windows used in cooperation with a super-insulated frame can facilitate solar heat gain



## Passive window shading

Overhang

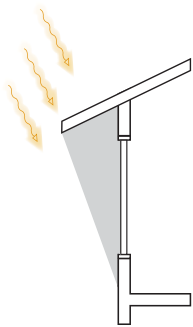

Louvres

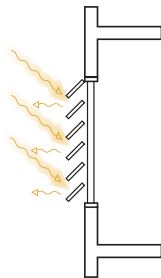

Sunshades

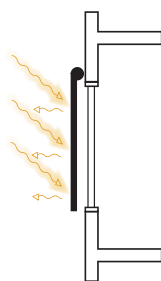

## 6.2 Location and Size of Windows

For a complete discussion of appropriate locations for windows, see the discussion in Section 3.2.

It is also important to remember that, in addition to having the lowest insulation value as a component of the building envelope, windows are also a source for thermal bridges. Therefore, an appropriate number of windows will mitigate unnecessary heat loss or gain. As a general rule of thumb, windows should not exceed  $2/3$  of the envelope.

In fact, due to the nature of thermal bridges, the number of individual windows should also be kept to a minimum – one slightly larger window is more efficient than two windows even if they equal the same area of window.

- Do not overglaze.
- Minimize the number of windows.

## 6.3 Shading

Appropriate use of shading can prevent too much heat from entering a building by shading the glass from direct sun light. This is particularly important for the south elevation during the warm summer months. Shading strategies can include using overhangs, eaves, louvres and sunshades to regulate solar access.

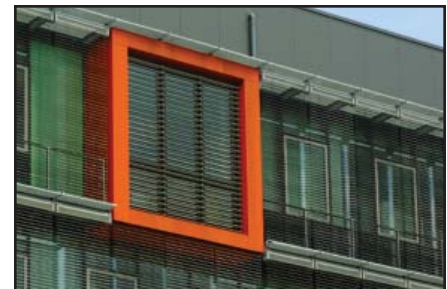

Louvres are used for shading on this building in Heidelberg, Germany

- Properly size and position overhangs to reduce solar gain during the times of the year it is not required

### Passive window shading

Curtains can be used to improve the performance of existing windows but are neither efficient nor effective as the solar heat gain is already inside the building envelope. Heavy curtains may reduce heat loss, but air movement will still encourage the warm air to escape. Blinds can work to reduce glare, but they are also not effective at blocking solar heat gain.

Exterior shading, such as automated blinds, are not truly passive as they consume energy, materials and resources in their manufacture. They also include working parts which are susceptible to failure.

Louvres offer non-mechanical exterior shading

## Windows:

Cost: \$\$\$\$

Window strategies are one of the most effective methods to make use of solar gain and limit energy loss. Proper attention to windows and shading can ensure maximizing winter sun, while also preventing summer overheating.

### Synergies/Barriers:

- It is important to balance solar considerations of windows with natural daylighting and view considerations.
- High performance windows can be expensive. Aim for the lowest U-value that is affordable and avoid overglazing.

### Impact on Energy Efficiency:

Appropriate use of this strategy can greatly increase the energy efficiency of a building.





photo:melis+melis+wimmers

# 7. Lighting

Daylighting and access to natural sunlight are essential for living spaces, as this quality of light promotes occupant comfort. Good daylighting eliminates the need for artificial lighting, reducing energy consumption for this purpose.

## 7.1 Interior Layout and Windows

When making decisions about lighting it is important to consider that appropriate building layout and orientation can reduce the need for artificial lighting and thus improve occupant comfort. Building layout should respond to the path of the sun, providing a sufficient supply of natural daylight through windows. South facing windows provide lots of daylight, as well as solar gains, while windows facing the northern elevation can deliver diffused lighting with minimal solar gain.

Good passive design should situate windows in multiple directions in order to balance interior lighting requirements. With the appropriate strategy, the amount and quality of light can be varied according to the lighting requirements of each space; direct light for kitchens, offices and workshops, and reflected or diffused light for living rooms or bedrooms.

- Use multiple window orientations for balanced lighting levels
- Choose lighting schemes based on room function

For further discussion of layout and windows, see Sections 4 and 6

When designing a passive lighting strategy, here are some questions to ponder:

*What is the primary function of this room and what type of light does it require?*

*When will the room be occupied (morning, afternoon, evening)?*

*What is the most appropriate style and placement for windows considering the path of the sun?*

## 7.2 Skylights vs. Solar Tubes

Although skylights can bring in lots of natural daylight, they are also a source of heat loss in the winter and heat gain in the summer.

Solar tubes, on the other hand, are simpler to install and provide daylight without the associated heat gain and a minimal amount of heat loss. Solar tubes are lined with reflective material to reflect and diffuse light to isolated areas.

- Use reflection techniques and solar tubes to funnel daylight into the house

## 7.3 Clerestory Windows

A clerestory wall is a high wall with a row of overhead windows that

## Types of Daylighting

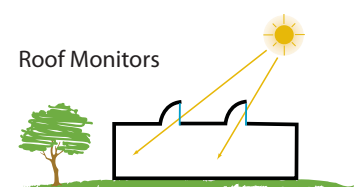
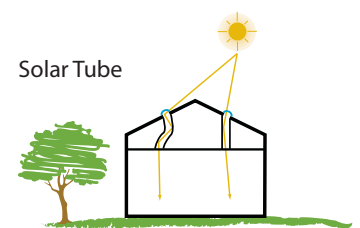
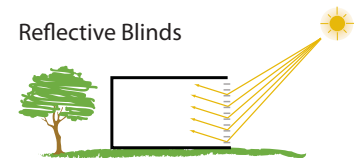
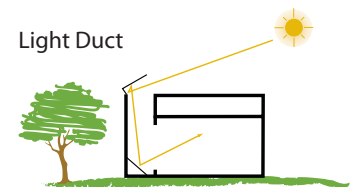
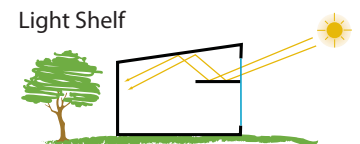

## Types of Daylighting continued...

Atrium

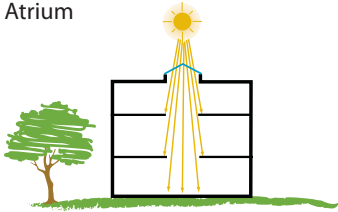

Clerestory

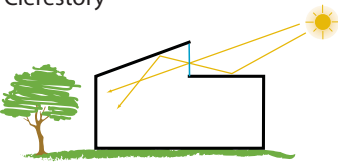

External Reflectors

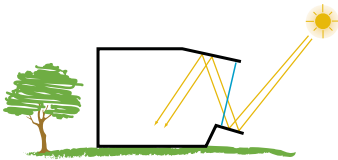

can allow in light. When clerestory windows are opened they can also act to cool the room by creating convection currents which circulate the air.

- Position clerestory windows to face south, with eaves to block the hot summer sun



### Heat gain from artificial lighting fixtures

Less than 10% of the energy use of a standard incandescent bulb (e.g. 40W, 60W, 100W tungsten filament bulbs) is converted to visible light, with the rest ending up as heat energy. Using more energy efficient light bulbs will ensure energy is efficiently directed to deliver its assigned purpose, in this case artificial lighting.

Compact Fluorescent Lights (CFLs) are the most significant development in home lighting, lasting up to 13 times as long as incandescent bulbs and using about ¼ the amount of electricity. New and improved colour renditions give a warmer light than older CFL technology.

Tungsten-halogen lamps are a newer generation of incandescent lights that provide a bright, white light close to daylight quality. These are powerful high-voltage lamps best used for general illumination.

More energy-efficient, low-voltage halogen lights are ideal for accent lighting. These lamps can last as long as 2000 hours and save up to 60% of the electricity used with incandescent lights.

Automation techniques and smart technology also help to mitigate high energy use. Dimmer switches and motion detectors can automatically adjust to conditions based on a predetermined schedule.

- Reduce as much as possible the reliance on artificial light
- Increase illumination effectiveness by using light coloured sources
- Use low wattage bulbs close to where they are needed
- Use energy efficient bulbs instead of regular incandescents
- Eliminate the unnecessary over-use of electricity with the use of dimmers, timers, motion sensors and cupboard contact switches





#### 7.4 Paint as a Passive Lighting Strategy

The albedo of an object refers to its capacity to reflect light. Light coloured paints can make spaces look and feel brighter while also mitigating the heat island effect through reduced heat absorption.

In winter, when solar radiation is not as intense and solar gains are sought after, high albedo surfaces adjacent to the house can reflect solar radiation into the house, to be

absorbed by the internal thermal mass. This strategy also provides daylight into the interior, as well as increasing nighttime lighting levels.

- Select appropriate surfaces to paint with light coloured paint or other high albedo material
- Decide where light is required and balance with heat considerations
- White painted windowsills can increase the amount of light into a room by reflecting outside light

□ Light coloured paints can make spaces look and feel brighter while also mitigating heat island effect.

#### Heat Island Effect

A heat island is an area, such as a city or industrial site, having consistently higher temperatures than surrounding areas because of a greater retention of heat by buildings, concrete, and asphalt. Causes of the “heat island effect” include dark surfaces that absorb more heat from the sun and lack of vegetation which could provide shade or cool the air.

**Lighting:**

**Cost:** \$\$\$\$ - \$\$\$\$\$

Passive lighting implies maximizing the use of natural daylighting in order to reduce the reliance on artificial lighting fixtures, which can be costly and inefficient.

**Synergies/Barriers:**

- Lighting strategies need to be balanced against solar heat gains.
- Clerestories and solar tubes can be appropriate where privacy is necessary.
- When choosing window styles for lighting remember to keep in mind other passive design best practices such as quality of windows and ventilation.
- High gloss paint leads to acute brightness – to achieve passive lighting use matte paint to deliver a softer brightness.
- Shade reflective surfaces with overhangs, trees or vegetation to mitigate unwanted heat gain in the summer.

**Impact on Energy Efficiency:**

Decreasing dependence on artificial lighting can help to curb energy consumption but natural light also contributes to higher occupant comfort. This strategy can be achieved with minimal extra associated costs.

# 8. Ventilation

When there is a difference between outdoor and indoor temperature, ventilation can be accomplished by natural means. Strategically placed windows make use of prevailing winds to allow ventilation, bringing in fresh air while removing warm or stale air. Ventilation also has an impact on heating and cooling.

When considering ventilation strategies, it is helpful to consider the following questions:

*How will the window contribute to occupant comfort?*

*Where should windows be located to achieve the desired impact?*

## 8.1 Window Placement

The height and opening direction will affect the degree to which a window can take advantage of prevailing winds. Well thought out height and placement will direct air to where it is needed, while choosing windows that either open inward, outward or slide will affect the amount of air that can be captured.

Though ventilation has an impact on heating and cooling it also has stand alone merits to improve occupant comfort through appropriate access to fresh air.

- Know the patterns of prevailing winds
- Identify wind flow patterns around the building
- Account for site elements such as

vegetation, hills or neighbouring buildings which will impact breezes

- Orient fenestration and choose a style that catches and directs the wind as required

## 8.2 Stack Effect and Cross Ventilation

The following strategies can effectively encourage passive ventilation in a house.

Stack effect is achieved by placing some windows at lower levels (in the basement or at floor level), while others are placed at higher levels (at ceiling height or on the top floor). The lighter, warm air is displaced by the heavier, cool air entering the building, leading to natural ventilation. This warm/light interaction acts as a motor that keeps the air flowing, leading to what is called the 'stack' or 'chimney' effect. The greater the temperature difference, the stronger the air flow generated.

This kind of natural ventilation is appropriate for summer months, as it may also cool the interior space, reducing the need for electric fans or pumps traditionally used for cooling. This in turn can lead to lower energy consumption.

### Stack effect

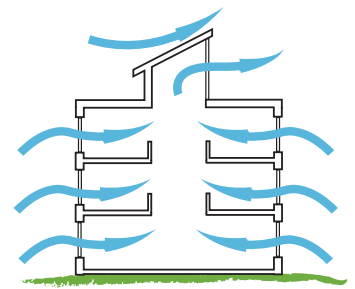

### Cross ventilation

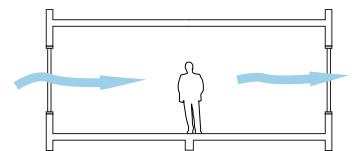



Cross ventilation occurs between windows on different exterior wall elevations. Patio and screen doors are also effective for cross ventilation. In areas that experience unwanted solar gain, operable clerestory windows or ceiling/roof space vents can aid with ventilation and cooling (see Section 8.3).

- Place windows where it is possible to achieve either stack effect or cross ventilation where required
- Use appropriate window style to achieve desired effect

### 8.3 Window Style

The style and operability of a window can determine maximum levels of ventilation achievable. Louvres or hinged/pivoting units that open to at least 90 degrees can offer the greatest potential for ventilation. Awning, hopper or casement windows, opened by short winders, provide the least potential.

- Maximize window opening and use hinged windows which can redirect breezes

### 8.4 Heat Recovery Ventilators

Heat recovery ventilators, or HRVs, are not strictly passive technology, but are recommended as part of a comprehensive passive design strategy. Ventilation which makes use of an HRV is more efficient, as the system reclaims waste energy from exhaust airflows. Incoming fresh air is then heated using this energy, recapturing 60 to 80 percent of the heat that would have been lost.

Passive design essentially encourages a very tight building envelope, while an HRV ensures a continuous supply of fresh air to this airtight interior. Filtration of the air through an HRV also stops dirt from entering the building, and can help to prevent development of mould.

### Heat recovery ventilator

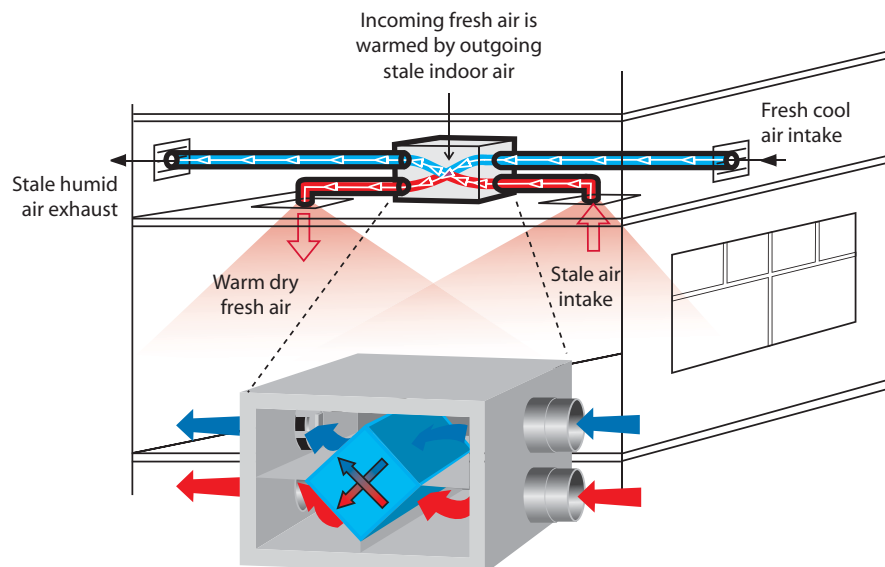

- Aim for a heat recovery rate greater than 75%, an leakage rate of less than 3%, and electricity efficiency of the unit greater than 0.4 Wh/m<sup>3</sup> (0.04 Btu/ft<sup>3</sup>)
- Provide ventilation controls that have user-operated settings for “low”, “normal” and “high”, and consider additional controls in kitchen and baths/toilets

**Ventilation:**

**Cost: \$\$\$\$\$ - \$\$\$\$\$**

Natural ventilation eliminates the need for big mechanical systems and can provide occupant control over thermal comfort.

**Synergies/Barriers:**

- Keep in mind that site conditions affect the ability to capture wind: allow for landscape, building shape and prevailing winds.
- Security and wind driven rain should also be considered when deciding window or door placement.
- HRVs require additional ducting to bring the exhaust air back to the HRV unit.
- Exhaust from nearby cars and other external pollutants should be accounted for.
- Unwanted heat loss can be reduced by preheating incoming air prior to distribution (using an HRV or other system).

**Impact on Energy Efficiency:**

Using passive strategies for ventilation can leverage natural climatic conditions for little or no extra cost.



# 9. Thermal Mass

Thermal mass is a measure of a material’s capacity to absorb heating or cooling energy. Materials such as concrete or bricks are highly dense and require a lot of energy to be heated or cooled. On the other hand, materials such as timber are less dense and do not need to absorb much energy for smaller changes in temperature. The more energy it takes to affect a temperature change of the material, the higher the thermal mass. The time it takes for the material to store and then release the heat energy is referred to as the *thermal lag*.

The thickness of a material impacts its energy storage capacity. For example, steel studs have a greater thermal mass than wood studs. The density of insulation materials differs and further affects thermal resistance values.

**Table 5**  
Common density values

Material	density
Foams	15-40 kg/m <sup>3</sup>
Wood Fibre	160 kg/m <sup>3</sup>
Fibreglass	50-60 kg/m <sup>3</sup>

The simple application of thermal mass can work to passively heat or cool a building, as internal changes in temperature can be moderated to remove extremes of heat or cold. The reverse is also true; inappropriately located thermal mass can cause external temperatures to disproportionately affect internal thermal comfort.

Before increasing thermal mass to an area of a building, consider:

*Will this location be best to exploit solar gain?*

*Can this location be shaded to avoid gain when it is not required?*

## 9.1 How to Use Thermal Mass

How can this be applied to low rise wood framed construction ?

When using thermal mass it is critical to understand that it behaves differently than insulating material. Thermal mass is the ability of a material to store heat energy and then release it gradually. Insulating materials, on the other hand, prevent heat from passing through them. In fact, many high thermal mass materials display poor insulation characteristics.

The embodied energy in some thermal mass materials may also be taken into consideration. Some materials, such as concrete,

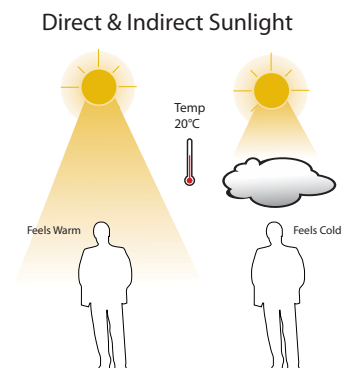

## Thermal Mass

### Structure with thermal massing:

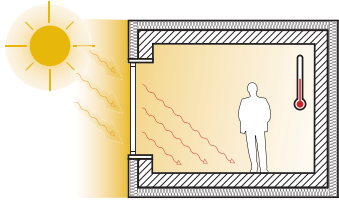

Sun enters room and heat is absorbed into flooring keeping the room temperature comfortable

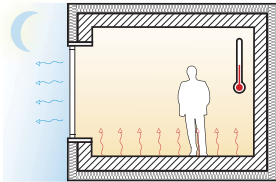

Heat that was absorbed is released during the cool evening to add warmth to the room

### Structure with no thermal massing:

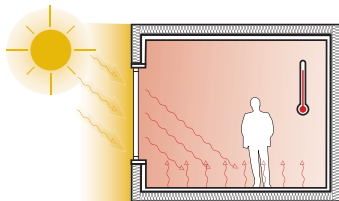

In a room without thermal massing, heat from the sun is reflected into the room causing uncomfortable warmer temperatures

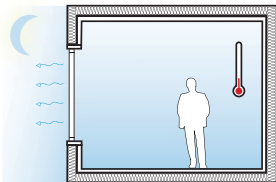

In the cool evenings, a room without thermal massing will be uncomfortably cold

require a lot of energy to manufacture and are inappropriate in relation to the actual energy savings they might deliver.

Mass situated on the south side of a building is most efficient for heating in Vancouver. The mass can absorb heat from the sun and then release this energy during the night. To avoid overheating, areas with high thermal mass should be shaded from this sun in the summer, or situated/landscaped to take advantage of cooling winds.

Thermal mass should generally be located on the ground floor, on the inside of a building, exposed to the indoor environment. Exposed

concrete floors or concrete block partition walls are very effective at absorbing thermal conditions (heat or cold).

- Use the south side for thermal mass, but apply appropriate shading for summer months
- Apply thermal mass on the ground level

## 9.2 Slab on grade construction

Slab on grade (SOG) is a very common method to create thermal mass. Generally about 4" thick, SOG should be insulated from the ground below to avoid losing heat in the winter.

### Radiant Heating

#### Radiant heat flooring vs. forced air heating

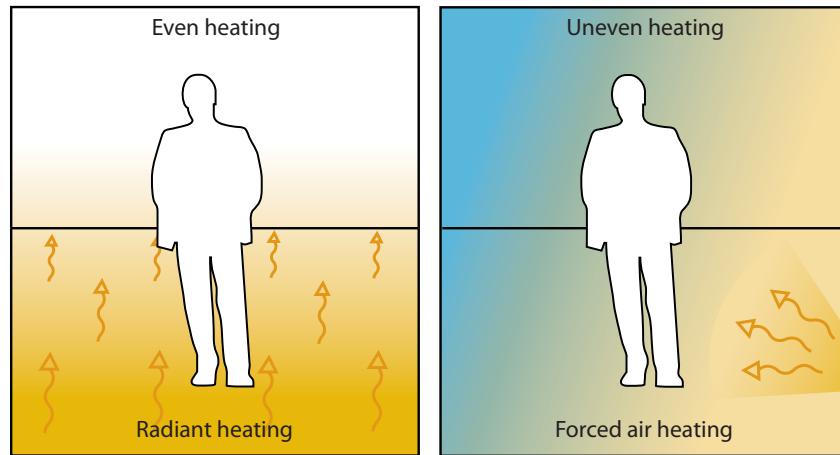

Radiant energy can be beneficial – this type of energy is emitted from a heat source and is different from tradition convection heating. This type of heating can penetrate all objects in its path and rather than heating the air, directly heats all objects in its path, including people.

This type of heating system can achieve the same level of thermal comfort using less energy, as heat is not lost to the air. Radiant systems include in-floor, ceiling panels or wall heating systems.

### Phase Changing Materials

There is growing interest in the use of phase changing materials in construction. These are materials that can either emit or store heat energy as they change from a solid to a liquid or vice versa at certain temperatures. Therefore, these materials can be used, like thermal mass, to manage indoor thermal comfort.

#### Thermal Mass:

Cost: \$\$\$\$ - \$\$\$\$\$

Thermal mass can be effectively used to absorb solar heat in winter and radiate it back to the interior at night.

#### Synergies/Barriers:

- Vancouver has minimal winter sun, so this strategy has limitations to significantly offset winter heating demands though it may be sufficient for shoulder season demands (spring and autumn).
- Naturally occurring thermal mass areas can be used to reduce cooling demands more easily – keep high thermal mass elements shaded or away from solar gains.

#### Impact on Energy Efficiency:

Allows the house to heat and cool itself based on heat release from materials, lowering the need for additional heating.





## 10. Density

In addition to building design, there are other elements that can impact the passive potential of a site. Density, measured in Vancouver as the ratio of building floor space to the site area, impacts energy consumption as well as the capacity of a building to be passively heated or cooled.



Density is regulated in most municipalities, including the City of Vancouver, by zoning by-laws based on development and planning policies. Though there is a process for rezoning applications, density cannot always be increased in every instance. Municipalities often have areas earmarked for greater density based on community plans, and the City of Vancouver has also introduced its EcoDensity policy, which aims to encourage density around transportation and amenity-rich nodes.

In general, large, single-family dwellings have a higher proportion of exterior wall surface and constitute lower density areas. These buildings require more energy for heating or cooling purposes, while 'denser', multi-unit buildings, townhouses or duplexes can take advantage of economies of scale and share or transfer heat between walls or floors thereby reducing overall energy demand. In fact, low-density developments comprising mainly single-family houses use nearly twice as much energy per square foot as multi-unit buildings in Canada.

□ **Multi-unit buildings take advantage of economies of scale and share or transfer heat between floors and walls thereby reducing overall energy demand.**



According to a 2006 study, low-density suburban development is more energy and GHG intensive by a factor of 2.0–2.5 than high-density urban core development.

The analysis is based on a per capita calculation. When this functional unit is changed to per square meter of living space, the factor decreases to 1.0–1.5. This suggests that the choice of functional unit is highly relevant to a full understanding of the effects of density, although the results do still indicate in many cases a marginally higher energy usage in low density development.

From:  
'Comparing High and Low Residential Density', Jonathan Norman, Heather L. MacLean, and Christopher A. Kennedy, *Journal of Urban Planning and Development*, Vol. 132, No. 1, March 2006, pp. 10-21

□ Single-family dwellings take up half of the land area in Vancouver. In fact, only 11 percent of the city's land area is currently used for multiple-unit dwellings, according to the City of Vancouver's EcoDensity website.



### Density

Density can mitigate pressure on municipal infrastructure including waste, sewer and energy infrastructure. Appropriate use of density can also create efficiencies in the use of this infrastructure, and lead to shared benefits from energy usage and common amenities.

#### Synergies/Barriers:

- Density is largely determined by wider municipal planning policy so there is little scope for variations on a building by building basis.

# 11. Benefits of Passive Design



The strategies in this toolkit offer suggestions for harnessing the power of the sun and decreasing the energy consumption requirements of a typical home. As in other parts of the world, it seems reasonable to be able achieve a reduction to just 15kWh/m<sup>2</sup>/year (heat/cool) if all strategies are used in combination. It is important to keep in mind that reducing consumption is the first step to designing energy efficient homes and approaching carbon neutrality (ie this should come before any discussion of on-site energy generation).

To get an idea of the possible impacts/benefits of passive design on energy consumption, consider the case study presented in the tables on the following page.

In short, a typical Vancouver single family home is 200 m<sup>2</sup>, with a 2x6 fully insulated stud wall and conventional windows with low-e windows. The average annual energy loss associated with a building of these specifications would equal roughly 16,000 kWh, or about 80 kWh / m<sup>2</sup> / year. The passive solar energy harnessed by this home would be relatively small, at about 1,200 kWh per year, or roughly 7.5% of the amount of energy lost. Annual heating demand would average 64 kWh / m<sup>2</sup> / year.



photo:melis+melis+wimmers

### Case Study

Table 6 shows the usual approach and the resulting energy consumption. The energy loss of 18,000 kWh is relatively high and the passive solar impact is with less than 7 percent extremely low.

The second example (Table 7) is based on a typical Vancouver single family home with a small rental unit in the basement. With a total floor area of 208 m<sup>2</sup>, the house was retrofitted during the last year.

**Table 6:  
Typical Vancouver Single  
Family Home**



Size of Building	208 m <sup>2</sup>
Wall assembly	basement 2x6 fully insulated stud wall. Concrete with 2" XPS
Windows	30 m <sup>2</sup> Conventional, low-e U Value=1.6 thereof 7.4 m <sup>2</sup> on south side
Energy loss	18,000 kWh ≈ 80 kWh / m <sup>2</sup> / year
Solar gain	1,200 kWh ≈ 6.6% of energy loss
Heating demand	69 kWh / m <sup>2</sup> / year

This home is lined up against the typical Vancouver house (Table 6) with no recent upgrades. The resulting energy consumption and loss of 18,000 kWh is relatively high, but not an unreasonable assumption. The passive solar harnessed by this building is less than 7 percent of consumption, which is extremely low but again, not an unreasonable assumption with recent construction and design practices.

The main differences between the original house and the improved example in the case study are:

- improved insulation thicknesses
- improved air tightness
- optimizing of heat bridges
- improved thermal quality of windows
- installation of heat recovery unit

With these improvements, total energy loss was reduced significantly despite the fact that it was possible to improve passive solar gain to only 10 percent of energy requirements, which is still very low performance.

**Table 7:**  
**Better Vancouver Single Family Home**



Size of Building	208 m <sup>2</sup>
Wall assembly	basement 2x6 fully insulated stud wall plus 2" exterior insulation. Concrete with 3" XPS
Windows	Ventilation with heat recovery 37 m <sup>2</sup> Triple pane and insulated frame U Value = 0.78 thereof 7.4 m <sup>2</sup> on south side 82% (air tightness @ 50Pa 0.77/h)
Energy loss	9,500 kWh ≈ 46 kWh / m <sup>2</sup> / year
Solar gain	1,000 kWh ≈ 10.5% of energy loss
Heating demand	29 kWh / m <sup>2</sup> / year

For comparison, the third example (Table 8) offers an estimate of the possible performance associated with a truly passively designed home. In this third instance, improvements would include:

- further increases to insulation
- window placement based on building orientation

Allowing the windows to be distributed according to solar gain potential increases the solar energy the building harnesses to 35 percent. By placing a larger proportion of windows on the southern elevation and less on the northern elevation, the passive design features of this building improve its performance by nearly fivefold over the first example.

**Table 8:**  
**Passive Vancouver Single Family Home**



Size of Building	208 m <sup>2</sup>
Wall assembly	basement 2x6 fully insulated stud wall plus 3.5" exterior insulation Concrete with 6" XPS
Windows	Ventilation with heat recovery 45 m <sup>2</sup> Triple pane and insulated frame U Value = 0.78 thereof 21.5 m <sup>2</sup> on south side 82% (air tightness @ 50Pa 0.6/h)
Energy loss	8,400 kWh ≈ 40 kWh / m <sup>2</sup> / year
Solar gain	3,200 kWh ≈ 38% of energy loss
Heating demand	15 kWh / m <sup>2</sup> / year (PassivHaus standard)



# Bibliography

Diamond, R. 1995. "Energy savings rise high in multifamily buildings." Home Energy Magazine

McMullen, R. 2002. Environmental science in building, Palgrave, New York.

Norman, J., H. MacLean & C. Kennedy. 2006. Comparing High and Low Residential Density: Life-Cycle Analysis of Energy Use and Greenhouse Gas Emissions, Journal Of Urban Planning And Development / March 2006

OEE NRCan 2006. Energy Use Data Handbook 1990 and 1998 to 2004

Light House Sustainable Building Centre. Cost assessment of a bundle of green measures for new Part 9 buildings in the City of Vancouver. 2008: City of Vancouver

Schaeffer, J. 2008. Solar Living Source Book, New Society Publishers, BC.

Pearson, D. 1998. The New Natural House Book. Fireside, NY.

Roaf, S. 2007. Ecohouse. Architectural Press, Oxford UK

Kachadorian, J. 1997. The Passive Solar House, Chelsea Green Publishing Company, Vermont, USA.

Tap the sun, Passive Solar Techniques and Home Designs, Natural Resources Canada and CMHC.

# i. City of Vancouver Policy Context

The City of Vancouver has a reputation as a leader in sustainable urban development.



## Green Homes Program

While developing passive design strategies, it is important to keep in mind the progress the City has already made in promoting green building. For Part 9 Buildings (low-rise wood frame residential), the City has adopted the Green Homes Program.

This program sets out higher standards for all new Part 9 buildings, including:

1. Building Envelope Performance:
  - i. Windows must have maximum U-Value of 2
2. Energy Efficiency:
  - i. At least 40% of hard-wired lighting should not accept incandescent lightbulbs
  - ii. Display metres should be installed that can calculate and display consumption data
  - iii. Hot water tanks should have insulation with a minimum RSI value of 1.76

□ This toolkit offers best practices to encourage and support the use of passive design in Vancouver.



□ **Part 3 Buildings are defined as structures over 3 storeys or greater than 600m<sup>2</sup>**

- iv. Hot water tank piping should have 3 metres of insulation with a minimum RSI value of 0.35
  - v. Gas fireplaces shall have electric ignition
3. Other:
- i. Toilets shall be dual-flush design
  - ii. Each suite shall have a Heat Recovery Ventilator
  - iii. An EnerGuide Audit is required at Occupancy Permit

### Part 3 Buildings

The City is implementing several actions in line with their *Green Building Strategy* (as above) and recently enacted policies directed at energy efficiency and GHG reductions:

1. Improve and streamline enforcement of the energy utilization within the building law
2. Adopt ASHRAE 90.1 2007 as new Energy Utilization By-law
3. Decrease overall building energy use requirements by 12-15% beyond ASHRAE 90.1 2001 to meet Natural Resources Canada (NRCan) Commercial Building Incentive Program (CBIP) requirements

### EcoDensity

The City has also implemented the EcoDensity policy, consisting of 16 actions. These actions apply only where there is a rezoning sought for a development.

1. All applicable buildings to be *either* LEED Silver with a minimum 3 optimize energy points, 1 water efficiency point and 1 stormwater management point *or* BuiltGreen BC Gold with an EnerGuide 80 rating
2. In addition, sites over two acres will require:
  - a. Business case analysis for viability of district energy systems
  - b. Layout and orientation which will reduce energy needs, facilitate passive energy solutions, incorporate urban agriculture and replicate natural systems
  - c. A sustainable transportation demand management strategy which includes requisite infrastructure
  - d. A sustainable rainwater management plan
  - e. A solid waste diversion strategy
  - f. For housing a range of unit types and tenures to enhance affordability

## Climate Neutral Network

The City of Vancouver is a signatory to the UN's *Climate Neutral Network* ([www.climateneutral.unep.org](http://www.climateneutral.unep.org)) and under this initiative has several climate action targets which include:

1. Making City operations climate neutral by 2012
2. Ensuring all new construction is carbon neutral by 2030
3. Achieving an 80% reduction in all community GHG emissions by 2050

Figure 3: Regional Timeframe Diagram

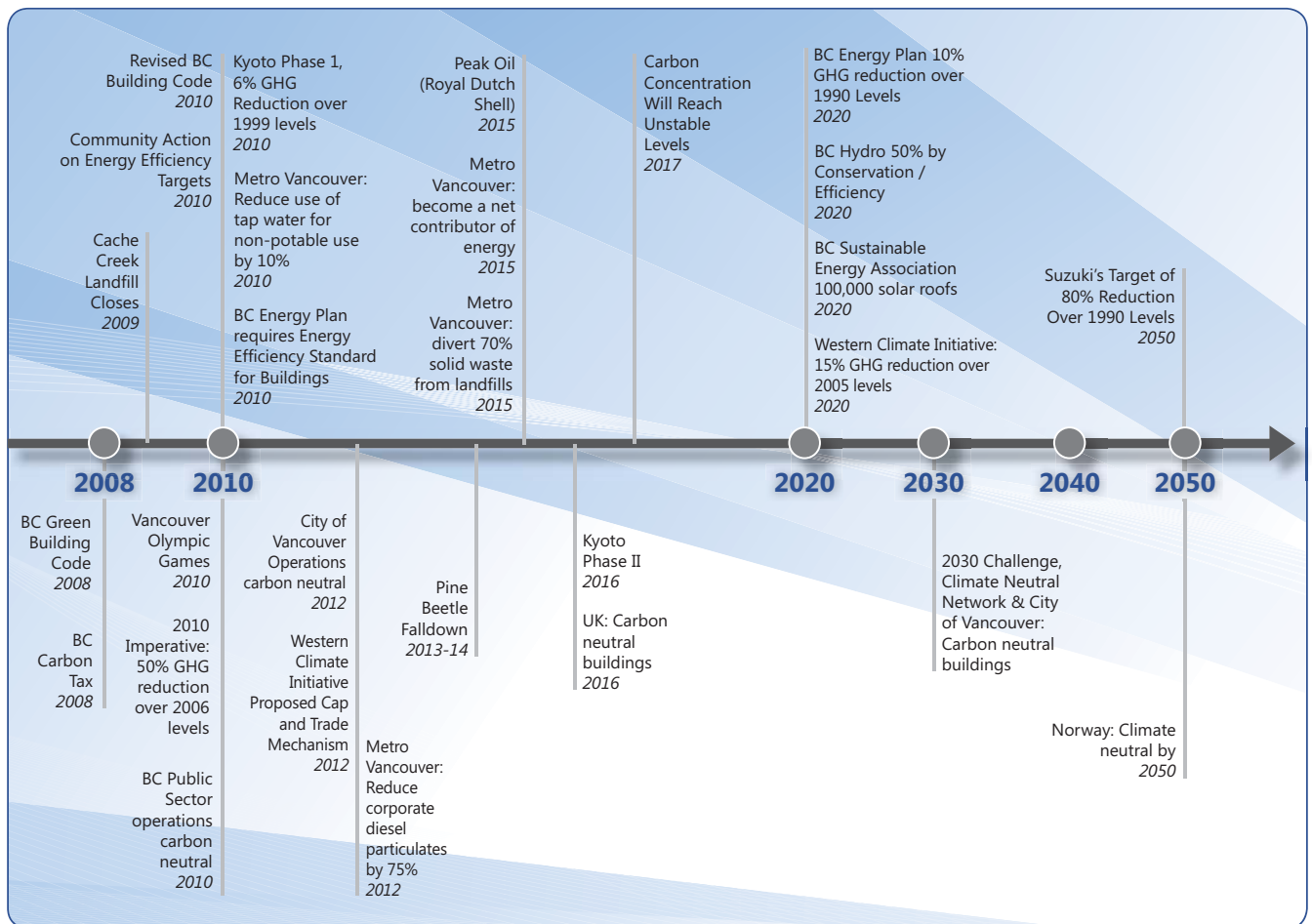

## ii. Acronyms and terms used in this report

Albedo	The ability for an object to diffuse and reflect light from the sun. Light coloured materials and paint have a high-albedo effect.
ASHRAE	American Society of Heating, Refrigeration and Air-Conditioning Engineers. ASHRAE publishes standards and guidelines relating to HVAC systems (heating, ventilation and air conditioning) and many are referenced in local building codes.
Building Envelope	The roof, walls, windows, floors and internal walls of a building
CFL	Compact Fluorescent Lights
EnerGuide	EnerGuide is the official Government of Canada mark associated with the labeling and rating of the energy consumption or energy efficiency of specific products, including homes. Homes are rated on a scale of 0-100. A rating level of 100 represents a house that is airtight, well insulated and sufficiently ventilated and requires no purchased energy.
Floor space	Floor space as used in this toolkit refers simply to the internal floor area bounded by the building envelope. However the method of measuring floor space precisely varies depending on the context-for example the Vancouver Building Bylaw contains a detailed description of the method of measurement of floor space for the purpose of submission for a Development or Building Permit and should be referred to for this purpose.
GHG Emissions	Green House Gas Emissions
Heat Island Effect	The term heat island refers to urban air and surface temperatures that are higher than in rural areas due to the displacement of trees, increased waste heat from vehicles, and warm air which is trapped between tall buildings.
HRV	Heat Recovery Ventilator
Indoor Air Quality (IAQ)	Indoor Air Quality (IAQ) refers to the composition of interior air, which has an impact on the health and comfort of building occupants. IAQ is affected by microbial contaminants (mould or bacteria), chemicals (such as carbon monoxide or radon), allergens, or any other pollutant that affects occupants.
LEED®	Leadership in Energy and Environmental Design green building rating system
Mechanical Systems	Conventional systems that use fans and pumps to heat, ventilate and condition the air.
PassivHaus	PassivHaus is a rigorous European home design standard developed in Austria and Germany, which regulates input energy to a maximum 15 kWh / m <sup>2</sup> / year – about one tenth of that in a typical new 200 m <sup>2</sup> Canadian house.
Solar Gain	(also known as <b>solar heat gain</b> or <b>passive solar gain</b> ) refers to the increase in temperature in a space, object or structure that results from solar radiation. The amount of solar gain increases with the strength of the sun, and with the ability of any intervening material to transmit or resist the radiation. In the context of passive solar building design, the aim of the designer is normally to maximise solar gain within the building in the winter (to reduce space heating demand), and to control it in summer (to minimize cooling requirements).



Thermal Bridges	A thermal bridge is any part of a construction through which heat can travel faster and with less resistance than other parts.
Thermal Comfort	Thermal comfort is defined by ASHRAE as human satisfaction with the surrounding environment, formalized in ASHRAE Standard 55. The sensations of hot and cold are not dependent on temperature alone; radiant temperature, air movement, relative humidity, activity levels and clothing levels all impact thermal comfort.
Thermal Mass	Thermal mass is the ability of a material to store heat. Thermal mass can be incorporated into a building as part of the walls and floor. High thermal mass materials include: brick, solid concrete, stone or earth.

## Contents Continued...

### Appendix C – Vancouver Climate Characteristics ..... 45

C.1 Overview .....	45
C.2 Air Temperature and Humidity .....	45
C.3 Solar Radiation .....	49
C.4 Wind.....	50
C.5 Precipitation.....	51
C.6 Outdoor Design Temperatures .....	51

### Appendix D – Energy Performance Targets..... 53

### Appendix E – Energy Modeling..... 55

E.1 Introduction.....	55
E.2 Study Cases .....	55
E.3 Baseline Model .....	57
E.4 Orientation.....	58
E.5 Balcony Buffer Space.....	60
E.6 Window to Wall Area Ratio.....	63
E.7 Window Performance .....	66
E.8 Solar Shading .....	70
E.9 Thermal Mass .....	74
E.10 Wall Insulation .....	77
E.11 Infiltration.....	80
E.12 Heat Recovery Ventilation.....	82
E.13 Natural Ventilation.....	85
E.14 Strategy: Passive Heating .....	89
E.15 Strategy: Passive Cooling .....	92
E.16 Strategy: Residential Approach.....	94
E.17 Strategy: Commercial Approach.....	97
E.18 Commercial Schedule .....	99

### Appendix F – Case Studies .....101

O <sup>2</sup> .....	101
Millenium Water – Vancouver’s Olympic Athlete’s Village .....	102
Pacific Institute for Sport Excellence, Camosun College .....	103
Liu Institute for Global Issues, UBC .....	104
Revenue Canada Offices .....	105
City of White Rock Operations Centre.....	106
Dockside Green .....	107
Butchart Gardens Carousel Building .....	108
Hillcrest Community Centre .....	109

# 1. Executive Summary

## 1.1 Purpose

This document presents best practices for the application of passive design in Vancouver. It is intended to establish a common vision and definition of passive design and support decision making for new developments<sup>1</sup> that will maximize occupant health and comfort and minimize energy use by relying less on mechanical and electrical systems. Furthermore, it is intended to move the Vancouver design community toward a new, higher standard of energy efficiency without sacrificing thermal comfort.

This document is not prescriptive, but rather discusses and analyzes recommended design approaches and the energy saving opportunities each presents. Additionally, the modeling results shown are useful and valid but do not replace the value of project-specific modeling.

## 1.2 Navigating this Toolkit

This toolkit is organized into three main sections:

1. Context
2. Passive Design Strategies
3. Passive Design Elements

Context provides the fundamental frameworks for understanding and implementing passive design. Passive Design Strategies lays out the overarching strategies that will optimize comfort and

minimize energy requirements on new developments in Vancouver. Each strategy is made up of several design elements. Each element is addressed in further detail in Passive Design Elements.

Finally, the appendices provide supporting information, including detailed energy modeling analysis.

## 1.3 Summary of Recommendations

When building in Vancouver, it is recommended that designers adopt a passive design approach that uses the building architecture to maximize occupant comfort and minimize energy use. Design teams that understand the basic concepts and implement the strategies recommended in this toolkit will optimize passive performance and achieve the many spin-off benefits of energy efficient, thermally comfortable buildings. Of course, the application of passive design must be carefully considered within the specific constraints and opportunities of each project.

The key passive design recommendations for buildings in Vancouver are summarized below. (See Appendix E for energy modeling to support all statements.)

- Design each facade specific to its orientation.
- Where possible, minimize east and west exposures to avoid

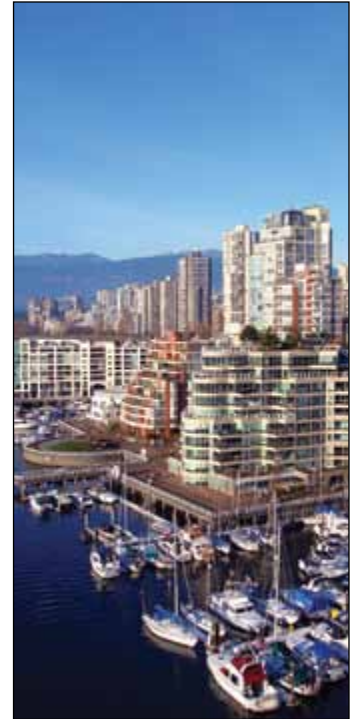

□ When building in Vancouver, it is recommended that designers adopt a passive design approach that uses the building architecture to maximize occupant comfort and minimize energy use.

<sup>1</sup> This toolkit is intended for Part 3 buildings, as per the National Building Code of Canada (2005).



## □ Design for cooling by natural ventilation.

unwanted solar gains.

- For better energy performance, attempt to limit windows to 50% on any facade (for best performance, limit windows to 30%), taking into account other aesthetic and livability criteria. If higher window to wall area ratios are desired, incorporate high performance windows or a double facade and optimize shading.
- Target overall wall assembly RSI values between 2.3 (ASHRAE minimum) and 2.9. Use modeling to assess project-specific benefits, as the impact of insulation depends greatly on window to wall area ratio.
- Use an air-tight envelope to minimize uncontrolled infiltration.
- Use heat-recovery ventilation during heating season only, and design for natural ventilation and cooling by natural ventilation throughout the rest of the year.
- For residential buildings, use clear glass with good insulating value (low U-value with low-e coating). Mitigate unwanted solar gains with external shading and allow for passive cooling by natural ventilation.
- For commercial buildings, use either clear glass with effective external shading elements or dark or reflective glass (low shading coefficient) to control unwanted solar gains. Regardless of shading option, the glass should have good insulating value (low U-value with low-e coating). Remove internal heat gains with other passive elements (e.g., natural ventilation).
- Incorporate overhangs providing shading angles of 20°-30° off vertical (measured from the bottom window sill to the edge of the overhang) on south-facing windows.
- Incorporate operable external shading on east-, south- and west-facing windows.
- Use thermal mass that is exposed to the conditioned space and combine it with other passive elements to achieve its full energy-savings and comfort potential.
- Incorporate buffer spaces on all exposures whenever possible to optimize comfort and reduce both peak load and overall heating and cooling energy requirements.
- Design for cooling by natural ventilation in all building types.
- Optimize the effects of passive heating and cooling strategies by strategically combining passive elements.
- Incorporate as many passive design elements as possible to optimize comfort and minimize overall energy use.

## 2 Context

### 2.1 Definition of Passive Design

“Passive design”<sup>2</sup> is an approach to building design that uses the building architecture to minimize energy consumption and improve thermal comfort. The building form and thermal performance of building elements (including architectural, structural, envelope and passive mechanical) are carefully considered and optimized for interaction with the local microclimate. The ultimate vision of passive design is to fully eliminate requirements for active mechanical systems (and associated fossil fuel-based energy consumption) and to maintain occupant comfort at all times.

Even though we may not achieve the ultimate passive design vision on every building, implementing the passive design approach to the fullest extent possible will lower building energy use. Building shape, orientation and composition can improve occupant comfort by harnessing desirable site-specific energy forms and offering protection from undesirable forms of energy. Through properly applied passive design principles, we can greatly reduce building energy requirements before we even consider mechanical systems.

Designs that do not consider passive thermal behaviour must rely on extensive and costly mechanical HVAC systems to maintain adequate

indoor conditions, which may or may not even be comfortable. Furthermore, even the most efficient technologies will use more energy than is necessary with a poorly designed building.

To successfully implement the passive design approach, one must first accomplish the following:

1. Understand and define acceptable thermal comfort criteria.
2. Understand and analyze the local climate, preferably with site-specific data.
3. Understand and establish clear, realistic and measurable energy performance targets.

### 2.2 Thermal Comfort

Proper understanding of the parameters around thermal comfort is a critical component of successful building and system design. It is especially important in passive design, where buildings must maintain thermal comfort without the aid of active mechanical systems for as much of the year as possible.

Thermal comfort refers specifically to our thermal perception of our surroundings. The topic of thermal comfort is a highly subjective and complex area of study. Through passive design, we can impact four indoor environmental factors that affect thermal comfort:

□ “Passive design” is an approach to building design that uses the building architecture to minimize energy consumption and improve thermal comfort.

<sup>2</sup> Also known as “climate adapted design” or “climate responsive design”



- Air temperature
- Air humidity
- Air velocity
- Surface temperatures

Each factor affects thermal comfort differently. The factors most commonly addressed in the conventional design process, air temperature and air humidity, in fact affect only 6% and 18% of our perception of thermal comfort, respectively. To take a more effective comfort-focused approach, we must also consider the temperature of surrounding surfaces and the air velocity, which account for 50% and 26% of thermal comfort perception, respectively.

The effectiveness of passive strategies depends on the range of acceptable thermal comfort parameters set for the project.

### 2.2.1 Thermal Comfort Models

As human thermal comfort perception is extremely complex and subjective, defining acceptable comfort parameters is particularly challenging. Despite these difficulties, several models for quantitatively measuring occupant comfort have been widely used. The two most relevant in this case are the Fanger and Adaptive Models.

The Fanger Model is most commonly used for typical buildings that rely solely on active mechanical systems. It defines comfort in terms of air temperature and humidity because these parameters are easy to measure and control. It prescribes a relatively narrow range of acceptable levels which, in common practice, do not vary with outdoor conditions on a daily or yearly basis.



*Thermal comfort is a very subjective term thus making it difficult to model.*

**Figure 1: Key thermal comfort parameters**

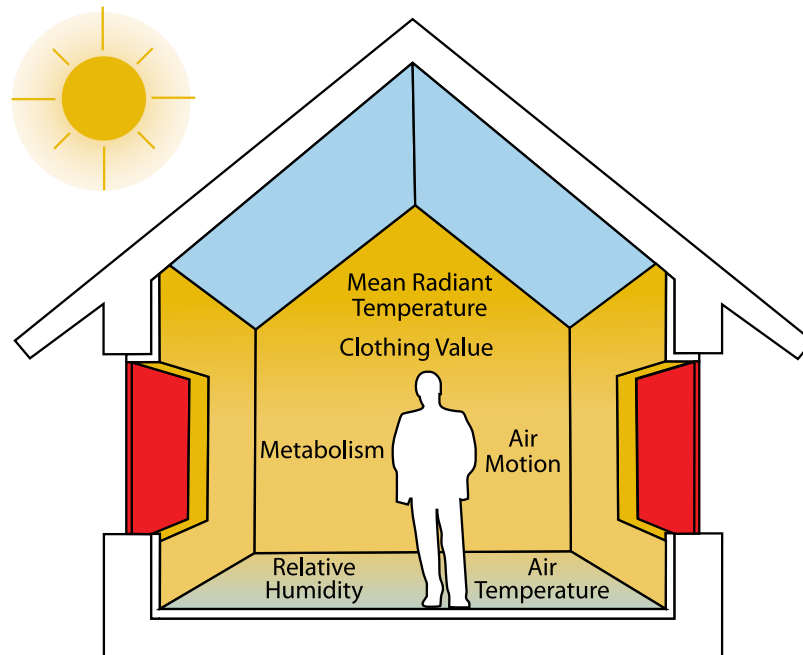

This suits the conventional approach which has heavy reliance on active mechanical systems regardless of the outdoor climatic conditions. But this can also lead to unnecessary energy consumption. Furthermore, this simplification does not account for the temperature of surrounding surfaces, the dominant factor affecting thermal comfort.

The complexity of human thermal comfort, particularly in passively designed buildings, can be better described by the lesser-known Adaptive Model.

The Adaptive Model correlates variable outdoor conditions with indoor conditions and defines comfort with a wider range of thermal parameters, making it more suited to buildings with passive features and natural ventilation. In the mild Vancouver climate, passive buildings can maintain acceptable thermal comfort within the parameters of the Adaptive Model for the majority of the year, with the exception of the coldest outdoor temperatures during winter.

Using the passive design approach and the Adaptive Model can significantly reduce a building's reliance on energy-intensive active mechanical systems.

The required strategies to achieve such passive performance are discussed in Section 3 of this toolkit. See Appendix B - Thermal Comfort for further details on both thermal comfort models.

### 2.2.2 Resultant Temperature

Resultant temperature<sup>3</sup> is the average of the air temperature and temperature of the surrounding surfaces (i.e., Mean Radiant Temperature or MRT). Surface temperatures affect occupant comfort by radiant heat transfer, the most dominant factor of human comfort perception, and air temperature affects comfort by convection and conduction, less dominant factors.

As long as the resultant temperature of the space remains within the targeted comfort range, occupants will feel comfortable, even as the air temperature fluctuates outside the comfort range. Conversely, when the resultant temperature of the space is outside the defined comfort range because of a cold or hot surface (e.g., a hot window on a sunny day), occupants will feel uncomfortable even if the desired air temperature set point is maintained.

The resultant temperature and MRT can be controlled by passive design strategies, which are discussed in Section 3 of this toolkit.

### 2.2.3 Free Run Temperature

Free Run Temperature (FRT) represents the natural temperature variation inside a building operating in an entirely passive mode, that is, without the involvement of active mechanical systems. An annual FRT

3 Also known as operative temperature;  $RT = (Average\ Air\ Temp + Mean\ Radiant\ Temp)/2$



□ Understanding the local climate is the foundation of passive design.

profile is a very effective tool for understanding a building’s passive response to its local climate. Once generated with building simulation software, an FRT profile can be used to test passive strategies. Effective passive strategies keep the FRT within the comfort range (or close to it) for most of the year. Optimizing the FRT minimizes the amount of energy required of the mechanical system.

*See Appendix B.4 - Free Run Temperature for further details.*

### 2.3 Vancouver Climate Characteristics

Understanding the local climate is the foundation of passive design. It guides the selection of appropriate passive design strategies and affects the extent to which mechanical systems are needed to maintain comfort.

Vancouver (49.18° N, 123.17° W) is located at sea level on the southwestern Pacific coast of British Columbia. In general, Vancouver has a temperate climate with mild temperatures and moderate humidity levels year round. Summers are pleasantly warm and dry and winters are relatively mild with high levels of precipitation. This weather pattern is due to the combination of the nearby ocean and the protection from the cold continental winter offered by the Coast Mountains rising abruptly from the ocean immediately to the north of the city.

The following table shows the average minimum and maximum air temperatures for Vancouver during the coldest month (January) and the hottest month (August).<sup>4</sup>

**Table 1: Vancouver Average Temperatures**

January		August	
Average Minimum	Average Maximum	Average Minimum	Average Maximum
0.5 °C	6.2 °C	13.2 °C	21.9 °C

<sup>4</sup> Source: <http://www.climate.weatheroffice.ec.gc.ca>

Because Vancouver is on the Pacific Northwest coast and it rains frequently, we often refer to Vancouver as “humid.” However, only Vancouver’s relative humidity is consistently high, not its absolute humidity. When high relative humidity coincides with low temperatures, the absolute amount of moisture in the air is still low. See Appendix C.2 for a more detailed discussion of humidity in Vancouver.

Vancouver receives moderate levels of solar radiation during spring, summer and fall.

The prevailing wind direction is from the east, followed in frequency by westerly winds. Due to the protection of the Coast Mountains, north winds are marginal.

The outdoor design temperatures for Vancouver as defined by the BC Building Code (2006) and ASHRAE 90.1 v.2007 are shown in Table 2.

## 2.4 Energy Performance Targets

Minimum energy performance is defined by current North American

standards in indirect, non-energy-specific terms. The standards fall short of what is being achieved in other parts of the world and what is possible in our Vancouver climate.

Both North American standards address only two passive building components: envelope insulation and window performance. Neither standard addresses other crucial passive design parameters affecting energy performance such as building shape, compactness, orientation, layout, and thermal storage effects of building mass.

The currently prescribed methodology does not provide clear, measurable energy performance targets. It is not possible to compare energy performance between buildings or determine how a building compares to the best energy performance in a given climate.

Establishing building energy performance targets in clear and measurable terms is a fundamental prerequisite of successful passive design. This new methodology has already been successfully

**Table 2: Vancouver Outdoor Design Temperatures**

	BCBC	ASHRAE
Winter Dry Bulb Temperature, 99.6%	-9°C	-8°C
Summer Dry Bulb Temperature, 1%	26°C	23°C
Summer Wet-Bulb Temperature (max coincident with 23°C dry-bulb)	19°C	18°C

5 In general, ASHRAE 90.1 is used in the US, and the Model National Energy Code of Canada for Buildings (MNECB) is used in Canada. However, local Canadian jurisdictions can choose to supersede MNECB, as Vancouver has done by adopting ASHRAE 90.1 v.2007.



implemented in most of Europe.<sup>6</sup> Minimum building energy performance is prescribed in terms of energy intensity, kWh/m<sup>2</sup>·year, for a specific building type in a specific climate. Maximum allowable energy intensity targets can either be determined from the historical building energy consumption data or derived from fundamental laws of physics such as with the free-run temperature methodology.

It is recommended that the City of Vancouver adopt maximum allowable energy intensity targets for specific building types. At present (late 2008), the City of Vancouver is working with BC Hydro and Terasen Gas to gather energy intensity data on existing buildings. Once an adequate and accurate data set has been collected, the City will be able to set energy intensity targets appropriate to the Vancouver climate and building market.

## 2.5 Integrated Design Process

Optimized building design requires the integration of many types of information from diverse sources into a comprehensive whole throughout the project. The Integrated Design Process (IDP) ensures all issues affecting sustainable performance are addressed throughout the process, from conception to occupancy. It is most critical to implement the IDP early on in the design activities, when issues can be addressed with minimal disruption. Active, consistent and coordinated collaboration between all team members and disciplines is critical to a successful IDP.

When implementing a passive design approach, many disciplines must collaborate to have the building and its surrounding site working together as a passive system. Figure 2 illustrates some of the many possible members of an IDP team.

Figure 2: Integrated Design Process Team

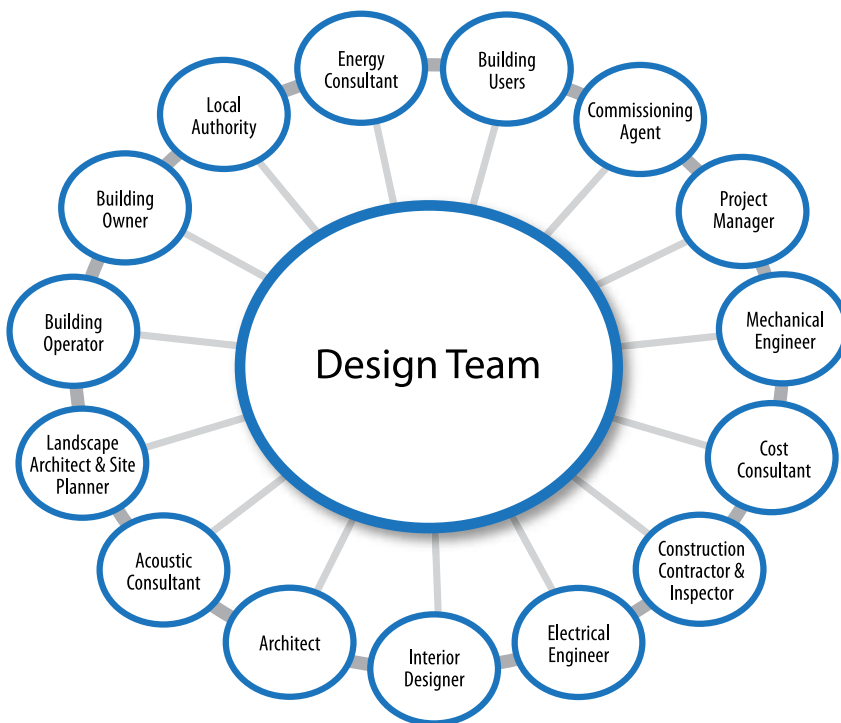

<sup>6</sup> European Energy Performance of Buildings Directive, MINERGIE (originated in Switzerland), Passive Haus (originated in Germany), etc.



# 3 Passive Design Strategies

Certain passive building elements have inherent synergies and can be combined to produce different and potentially greater improvements in comfort and building energy performance.

However, combining elements incorrectly or using certain elements in isolation can negatively impact thermal comfort and building energy efficiency. For example, large south and west facing windows beneficial for passive solar heating must be implemented in combination with high performance windows and external shading to protect the interior from excessive solar heat gains during summer in order to achieve the desired overall building efficiency gains.

It is important to note that these guidelines distinguish between cooling and ventilation. In a conventional forced-air HVAC system, ventilation and space temperature control functions are combined. However, there are great advantages to separating the function of space temperature control from the function of ventilation, especially when designing for optimal passive performance. This separation allows the choice of a hydronic heating and cooling system, using water instead of air for energy transfer. Water has over 3,000 times the energy carrying capacity of air, so hydronic systems can achieve dramatically increased system efficiency. The separation also allows the use of an independent ventilation system providing 100% fresh air.

Figure 3 below shows an example of the compounding effect of combining various passive elements on a typical building in Vancouver as thermal comfort is held constant. The baseline meets the minimum requirements of ASHRAE Standard 90.1. As each additional element is incorporated, the annual energy consumption is further reduced, finally achieving a high level of efficiency that would be impossible using any single measure in isolation. The passive design measures essentially build upon and improve the requirements and results of most commonly used North American energy standards methodologies.

Figure 3: Effect of Passive Design on Energy Intensity

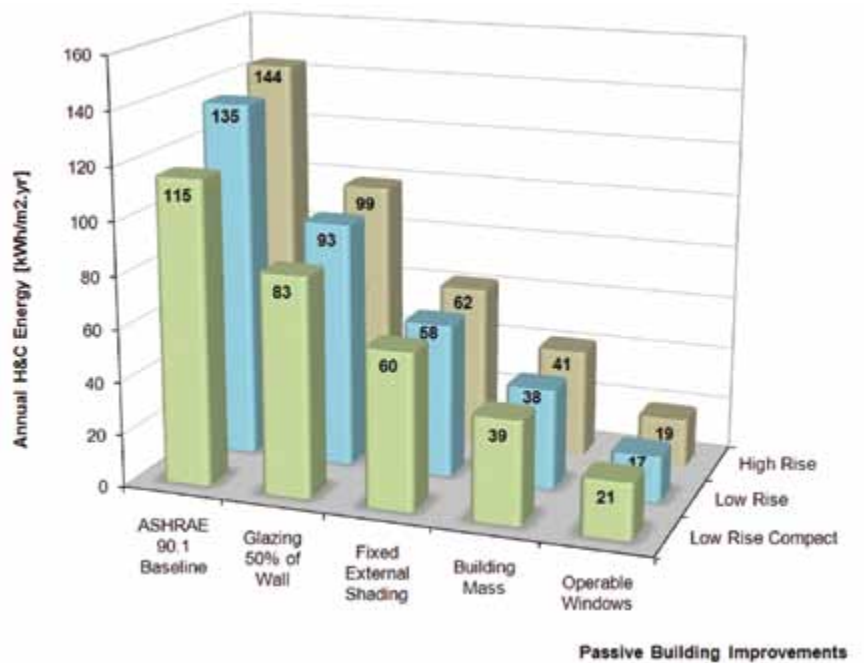

## CASE STUDY

Turn to page 102 to learn how the Millennium Water development takes advantage of cross-ventilation.

With many passive strategies, there is a tradeoff between heating performance and cooling performance. The building type and operation determine which strategies will have the best overall impact on energy performance. In all cases, building energy modeling specific to the project should be conducted. Once again it is important to note that the simulation results presented in this report are parametric comparisons only; they do not replace the value of project-specific modeling.

### 3.1 Passive Heating

Using building design to harness solar radiation and capture the internal heat gains is the only passive way to add free thermal energy to a building. Passive solar heating combines a well-insulated envelope with other elements that minimize energy losses and harness and store solar gains to offset the energy requirements of the supplemental mechanical heating and ventilation systems. Elements that contribute to passive solar heating include the following:

- Orientation
- Building shape
- Buffer spaces and double facades
- Space planning
- High-performance windows (clear, low-e)
- Mixed-mode heat recovery ventilation (HRV)<sup>7</sup>

- Low window to wall area ratio (N/E)
- High window to wall area ratio (S/W)
- Operable external shading
- High-performance insulation
- Thermal mass
- Minimized infiltration

### 3.2 Passive Ventilation

Passive ventilation strategies use naturally occurring air flow patterns around and in a building to introduce outdoor air into the space. Wind and buoyancy caused by air temperature differences create air pressure differences throughout occupied spaces. Buildings can be designed to enhance these natural air flows and take advantage of them rather than work against them.

Passive ventilation must be considered during the design process because many architectural features affect air flows through a building, including the building shape, layout of interior walls, floors and even furniture. Design features must strike a balance between privacy/noise attenuation needs and the desired path of least resistance for air distribution. Ventilation rates will also be affected by prevailing wind direction.

There are three common approaches to passive ventilation. The simplest form is single-sided ventilation with operable windows, where ventilation air enters and exhausts through the same window(s) on the same side of

<sup>7</sup> HRV is an active system; however, due to its effective synergies with passive ventilation, we are mentioning it here. See Appendix E for modeling results on the efficiency of this mixed-mode system.

the occupied space. There are design limitations on how large a space can be effectively ventilated this way: single-sided ventilation does not achieve a significant result unless ceilings are very high.

More effective is cross-ventilation, where operable windows on adjacent or opposing walls draw ventilation air across the occupied space. Designs should strive for at least two exposed walls per residential or commercial unit to allow for cross-ventilation.

Finally, in larger buildings with significant core spaces, induced ventilation with high spaces such as atria, stacks and wind towers may be necessary to provide adequate ventilation by strictly passive means. These strategic architectural features create optimized pathways for natural, passive ventilation.

The passive elements that contribute to natural ventilation include the following:

- Operable windows
- Buffer spaces and double facades
- Building shape
- Space planning
- Orientation
- Strategic architectural features
- Openings to corridors and between otherwise separated spaces
- Central atriums and lobbies
- Wind towers

Figure 4: Single-Sided Ventilation

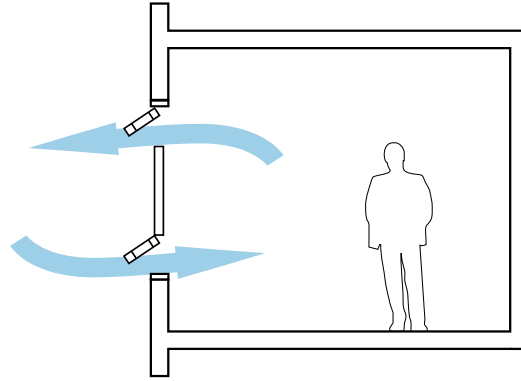

Figure 5: Cross Ventilation

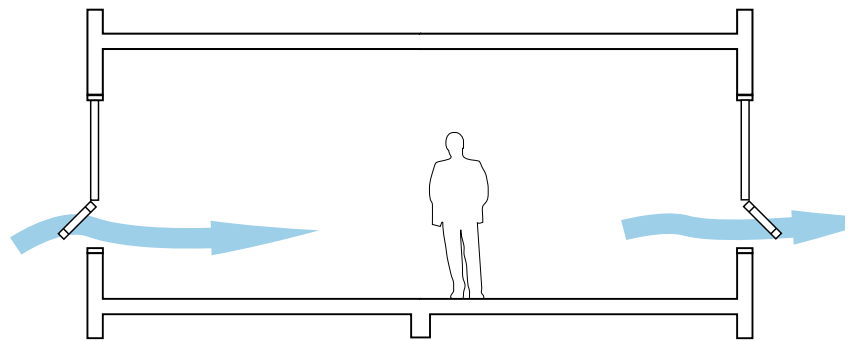
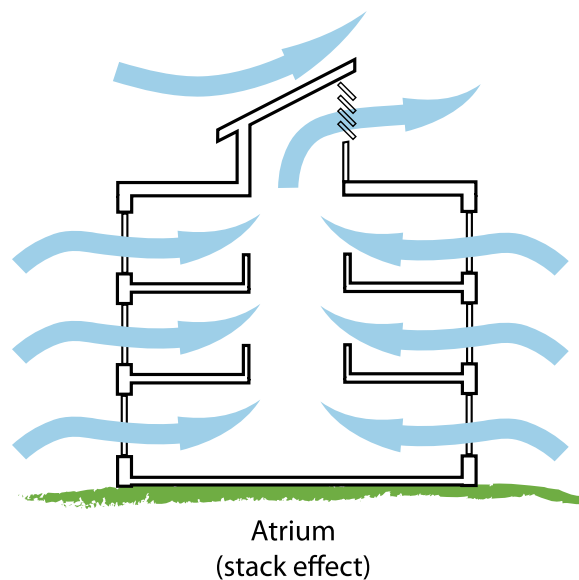

Figure 6: Stack Effect through an Atrium





□ Careful design is required to avoid overheating from direct solar gains and to minimize glare.

### 3.3 Passive Cooling

Passive cooling strategies prevent the building from overheating by blocking solar gains and removing internal heat gains (e.g. using cooler outdoor air for ventilation, storing excess heat in thermal mass).

Passive cooling strategies are often coupled with passive ventilation strategies, and the cooling function is achieved by increased passive ventilation air flow rates during periods when the outdoor air temperature is low enough to flush heat from the building.

Elements that contribute to passive cooling include the following:

- Fixed/operable external shading
- Thermal mass
- Low window to wall area ratio (S/W)
- Passive ventilation
- Nocturnal cooling
- Stacked windows
- Passive evaporative cooling
- Earth-tempering ducts

Nocturnal cooling uses overnight natural ventilation to remove heat accumulated in the building mass during the day. The cooler night-time air flushes and cools the warm building structure/mass.

Stacked windows allow cool air in at a lower window, creating an upward-moving vacuum that forces warm air out a high-placed window.

Evaporative cooling uses heat from the spaces to convert water from a liquid to a vapor, which changes the air from warm and dry to cool and moist. In order to cool a space by evaporative cooling, moisture must be added to an airstream. This can be achieved by drawing air across or through existing water (e.g., a water feature located within the building, a natural exterior body of water, a hydroponic living wall, etc.).

Earth tempering takes advantage of the relatively constant temperature of the ground at depths exceeding 1.5 m to provide tempering for building ventilation air. This requires burying a ventilation air intake path, also called an earth tube.

### 3.4 Daylighting

Daylighting maximizes the use and distribution of natural diffused daylight throughout a building's interior to reduce the need for artificial electric lighting. Careful design is required to avoid overheating and to minimize glare, and to complement passive heating and cooling strategies such as shading. In order to maximize energy savings, advanced electrical control systems like sensors should be integrated. The features which contribute to a daylighting strategy include:

- Space planning
- High ceilings paired with tall windows
- Window size and placement (window to wall area ratio)
- Interior surface colours and finishes
- Strategic architectural features
- Light shelves
- Skylights and light tubes
- Clerestories

The key energy savings benefit of daylighting is straightforward: daylighting reduces energy requirements for electrical lighting. Indirectly, daylighting can also reduce energy requirements for space cooling.

Daylighting strategies are highly project-specific: detailed building modeling and analysis is required to achieve an effective design and to estimate energy savings. As such, daylighting is not included in the parametric simulations of this study.

### 3.5 Applying the Strategies: Residential

In the Vancouver market, the vast majority of residential developments are medium- and high-rise towers. Residential spaces have night-time occupancy and relatively low internal heat gains (aside from intermittent cooking), which results in a heating-dominant residential energy profile in the Vancouver climate.

Specific passive approaches that will improve the overall energy performance of residential buildings in Vancouver include:

- Carefully detailed and constructed high-performance insulation in the envelope with minimal thermal bridging, including exterior walls and roofs.
- Clear, low-e, high-performance windows in combination with operable external shading to block solar gains during summer and admit solar gains during shoulder seasons and winter
- Note: any building in which the window to wall area ratio is greater than 50% will be challenged to achieve higher energy performance
- Unconditioned, enclosed buffer spaces (not regularly occupied) that cover the perimeter of the space, fitted with operable windows to provide natural ventilation from the exterior to the interior space when desired.
- Thermal mass on the interior side of the insulation, located in the floors, external walls, and walls between adjoining units (i.e., party walls).
- Compact and simple form.
- Air- and moisture-tight envelope.
- Mixed-mode ventilation using HRV during the winter only and passive ventilation throughout the rest of the year.

The following table displays the elements that positively contribute to the various passive design strategies for residential buildings.

	Relative Impact (★)	Passive Heating	Passive Cooling	Passive Ventilation	Daylighting
High-performance insulation	★ ★ ★	•	•		
High-performance windows	★ ★	•	•		•
Window to wall area ratio <50%	★ ★ ★	•	•		•
Buffer spaces	★ ★ ★	•	•	•	•
External shading	★ ★ ★		•		•
Thermal mass	★ ★	•	•		
Compact form	★	•			
Air- and moisture-tight envelope	★ ★	•			

These features were added to the parametric model one at a time to clearly illustrate the compounding benefit of each. Refer to modeling results in Appendix E.



### 3.6 Applying the Strategies: Commercial

Commercial buildings have different characteristics from residential buildings, such as greater internal heat gains from equipment and lighting, higher ventilation requirements, and different occupancy trends. Commercial buildings benefit from passive cooling, but in the Vancouver climate, design must strike a balance between heating and cooling performance.

Specific passive approaches that will improve the overall energy performance of commercial buildings in Vancouver include:

- Carefully detailed and constructed high-performance insulation in the envelope with minimal thermal bridging, including exterior walls and roofs.
- Solar gain control using either high-performance windows with low shading coefficient (tinted or reflective) or clear high-performance windows with a low-e coating in combination with operable external shading to block solar gains during summer and shoulder seasons and admit solar gains during winter.
- Window to wall area ratio limited to <50%.
- Double facades with operable shading elements and operable windows to act as thermal buffer spaces, preheat ventilation air in the winter, and block solar gains and provide natural ventilation in the summer.
- Building shape and massing that enhances natural ventilation and daylighting, ideally with central atriums and ventilation towers.
- Thermal mass on the interior side of the insulation, located in the floors, external walls, and walls between adjoining units (i.e., party walls).
- Passive cooling strategies, such as nocturnal ventilation to pre-cool spaces during summer and ventilation air intakes located in cool areas and delivered to the building using earth tubes.
- Air- and moisture-tight envelope.

The following table displays the elements that positively contribute to the various passive design strategies for commercial buildings.

	Relative Impact (★)	Passive Heating	Passive Cooling	Passive Ventilation	Daylighting
High-performance insulation	★★	•	•		
High-performance windows	★★★	•	•		•
Window to wall area ratio <50%	★★★	•	•		•
Double facades	★★	•	•	•	•
External shading	★★★		•		•
Narrow forms	★		•	•	•
Thermal mass	★	•	•	•	
Nocturnal ventilation	★★		•	•	
Pre-cooled ventilation air	★★		•	•	
Air- and moisture-tight envelope	★★	•			

These features were added to the parametric model one at a time to clearly illustrate the compounding benefit of each. Refer to modeling results in Appendix E.

### 3.7 Modeling Summary

Our modeling results indicate that incorporating passive elements and strategies effectively expands the range of outdoor conditions under which buildings can remain comfortable without active systems.

The figure below shows this effect of passive design strategies relative to the ASHRAE Comfort Zone. When outdoor conditions fall within the extended passive zone, a building that incorporates all of these passive

strategies will be comfortable without mechanical heating or cooling; when conditions fall outside of the zone, the building must rely on active systems to maintain thermal comfort.

In conclusion, passive design enables buildings to maintain occupant comfort throughout more of the year using less energy.

For the quantitative impact of individual passive elements and strategies, refer to Appendix E.

**Figure 7: ASHRAE Comfort Zone and Achievable Extended Comfort Range by Passive Design Strategies in Vancouver Climate**

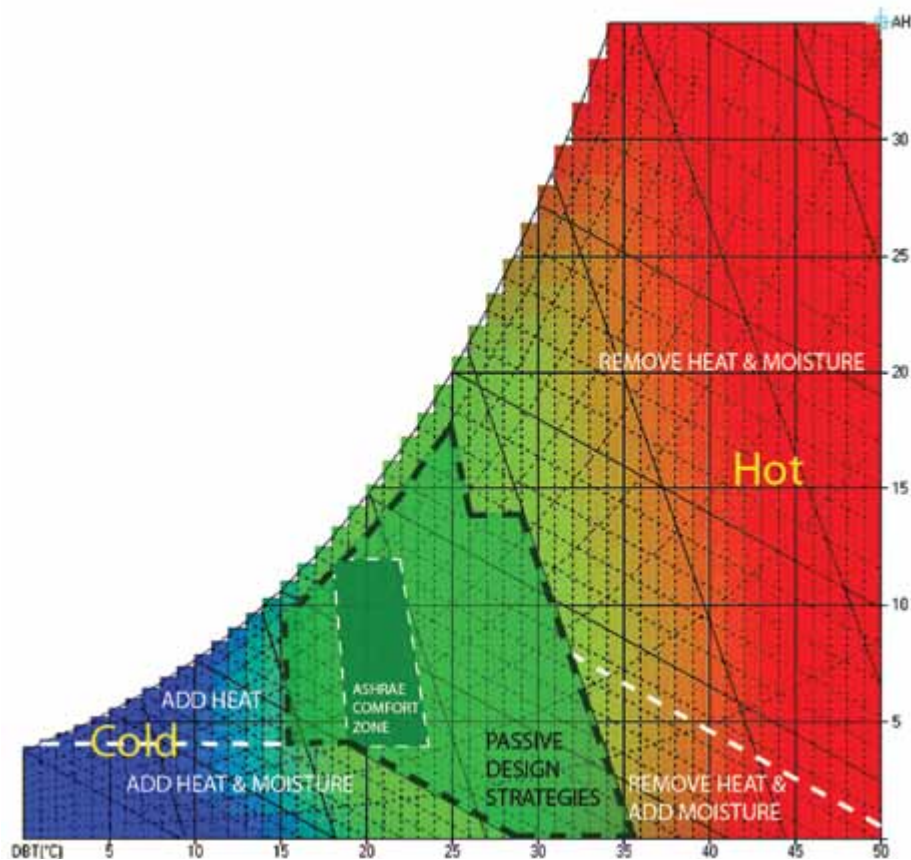



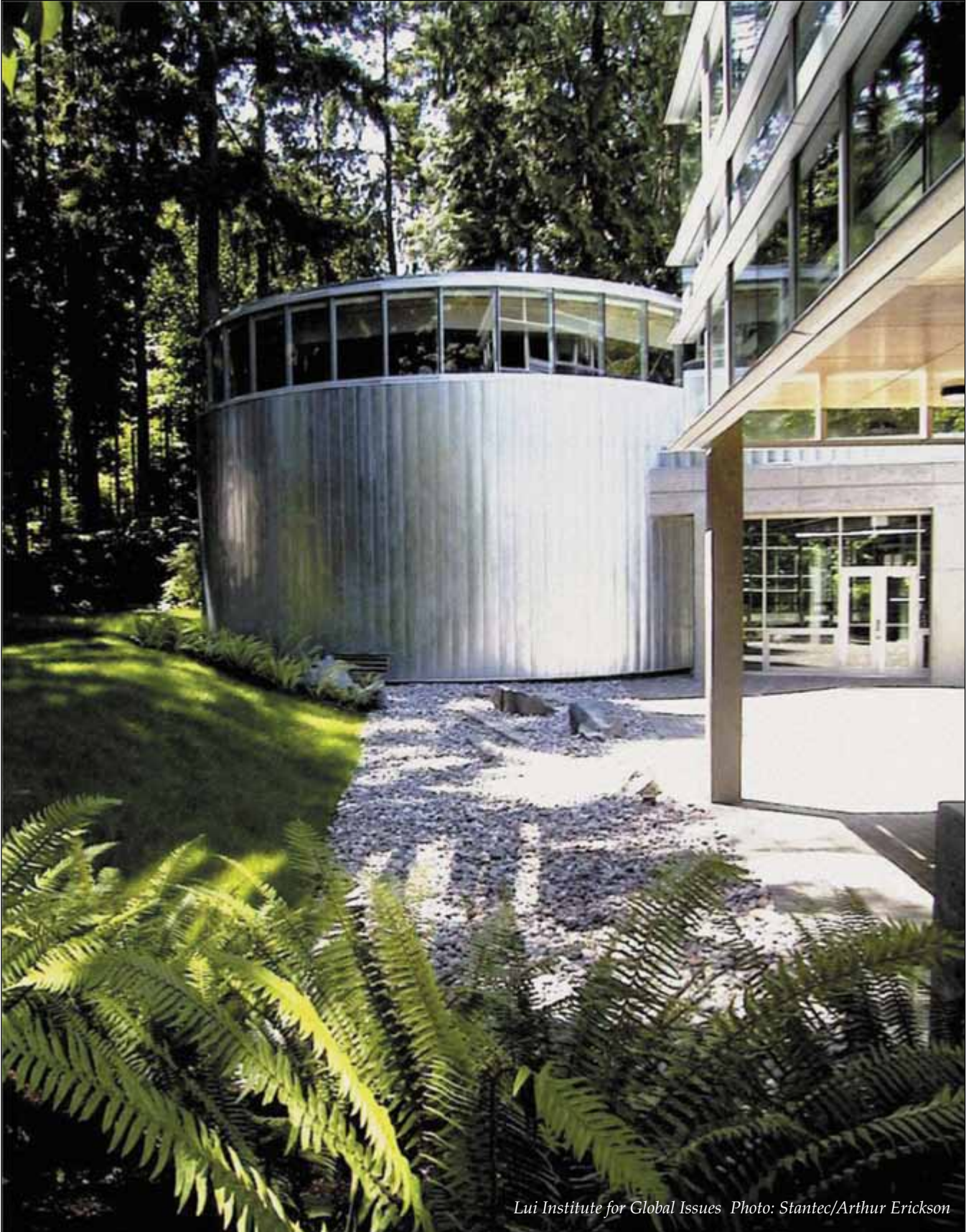

*Lui Institute for Global Issues Photo: Stantec/Arthur Erickson*

# 4 Passive Design Elements

The primary objective of passive design strategies is to reduce or even eliminate the need for active mechanical systems while maintaining or even improving occupant comfort. The passive design strategies discussed in Section 3 integrate the complementary passive design elements that follow to minimize heating and cooling loads. Performance of each individual passive element is discussed here in Section 4. They are presented in the general order a designer would encounter them throughout a design.

- Site and Orientation
- Building Shape and Massing
- Landscape Considerations
- Space Planning
- Buffer Spaces
- Windows
- Solar Shading
- Thermal Mass
- Thermal Insulation
- Air and Moisture Tightness

## 4.1 Site and Orientation

### 4.1.1 Overview

Many site considerations can affect the passive design approach, including urban design opportunities and constraints, building orientation on the site, shade from other buildings, wind patterns, proximity to industry, noise, and urban character. These all need to be considered to optimize the integration of passive design strategies and some may pose design conflicts. On the



□ in Vancouver Photo: Merrick Architecture

other hand, the integration of site considerations such as landscaping, wind and microclimate can influence the local architectural expression of a building.

Building facade orientation is one of the key elements for many passive design strategies. Facade orientation affects the energy and comfort implications of solar shading, window to wall area ratio, window position and performance, and choice of exterior colour.

A building's orientation determines the amount of solar radiation it receives. The roof surface receives the greatest intensity, but it is normally opaque and well-insulated. Building facades, which can have a significant window to wall area ratio, also receive sun in various amounts. The south facade will capture desirable solar gains during winter when the sun angle is low, making it ideal for passive solar heating during winter. On the other hand, window should be carefully placed on the east and west facades since they receive the second highest radiation intensities. Excessive solar heat gains on the west side can be particularly problematic as maximum solar intensity coincides with the hottest part of the day.

□ The primary objective of passive design strategies is to reduce or even eliminate the need for active mechanical systems while maintaining or even improving occupant comfort.



Figure 8: Vancouver's Two Distinct Grid Orientations



Figure 9: Seasonal Sun Paths

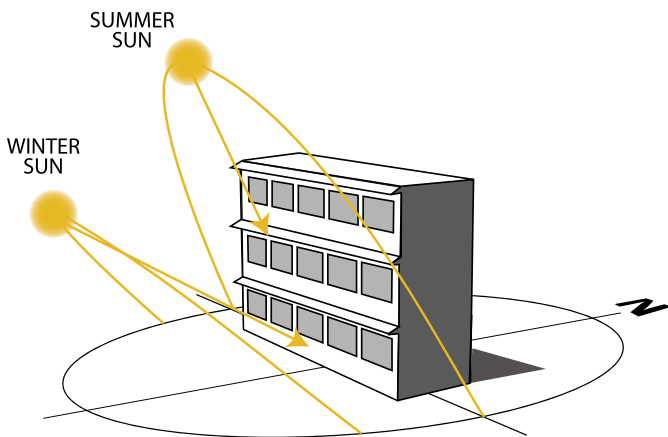
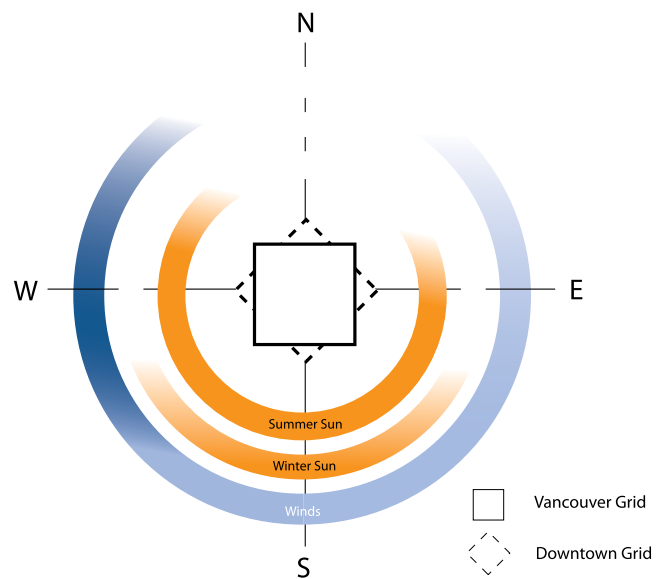

Figure 10: Facade Considerations



#### 4.1.2 Benefits

- Can greatly improve heating and cooling performance when optimized.
- Can greatly improve daylighting when optimized.

#### 4.1.3 Limitations

- Designing to optimal orientation is not always possible under specific urban conditions, typically limited by roads, existing development, urban design context, lot size, and lot orientation.

- Heritage conditions and related design guidelines can create opportunities for unique responses in the delivery of a passive design solution.

#### 4.1.4 Synergies

Since many passive design strategies are affected by orientation, responding to the different conditions of each facade is the most fundamental design decision a project team can make to passively design a building. For example, orientation and daylighting are very much linked. Optimum orientation will provide adequate daylight without glare or excessive solar gain.

#### 4.1.5 Vancouver Applications



Orientation that allows winter solar gains is desirable; therefore south-facing orientation is appropriate provided that it is well-shaded during summer.

Orientation will often not be optimum in the downtown grid. However, responding to the various facade conditions will significantly increase thermal comfort and decrease active mechanical system requirements.

## 4.2 Building Shape and Massing

### 4.2.1 Overview

Building shape and massing<sup>8</sup> have great potential to reduce building energy intensity, but they often fall under the influence of a complex array of factors (planning considerations, building type and use, feasibility and initial cost). Certain common building shapes greatly increase envelope area to volume ratio (e.g., thin high-rise towers), which can decrease building energy performance in heating dominant buildings. With a similar square footage, buildings with a smaller exterior envelope area will achieve better energy-efficient performance. A compact building shape significantly reduces the building's energy intensity and reduces the need for active mechanical systems as demonstrated in the modeling results shown below in Figure 11.

### CASE STUDY

Turn to page 103 to learn how the Pacific Institute for Sports Excellence's unique building shape provides solar shading.

- Building shape and massing have great potential to reduce building energy intensity.

Figure 11: Energy Intensity and Building Shape

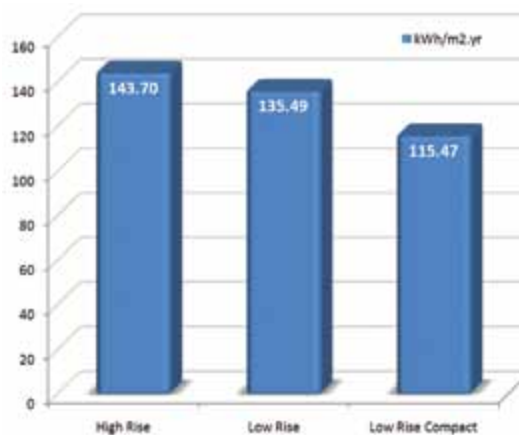

<sup>8</sup> "Massing" is used in this section to describe the overall geometry of the building. It is not to be confused with "thermal mass" (see Section 4.8).



Massing optimization can significantly improve passive performance, often without increasing the capital cost.

As one of the first design considerations, the massing of a proposed building must account for orientation and other site-specific conditions. Section 4.1 discusses orientation and its critical effects on massing and other passive design elements.

#### 4.2.2 Benefits

- Reduced heating and cooling energy consumption.
- Reduced peak heating and cooling loads.

#### 4.2.3 Limitations

- Must be carefully considered so as to not compromise the livability of the interior spaces provided (e.g., compromised daylighting; see synergies below).
- Must consider potential urban design conflicts related to street conditions, view corridors and other urban planning considerations.

#### 4.2.4 Synergies

Building massing functions in close relationship with other basic architectural passive design parameters such as orientation, envelope performance (including window location) and solar shading.

Massing must also be considered alongside daylighting needs and natural ventilation, which tend to improve in buildings with narrower profiles, courtyards and other features that increase envelope area.

#### 4.2.5 Vancouver Applications

- Heating-dominant residential buildings should be as compact as possible to improve their energy performance.
- Cooling-dominant commercial buildings should favour a longer shape along an east-west axis with more potential for passive cooling strategies.
- Buildings with compact form can be designed with features such as light wells and atriums to facilitate natural ventilation and daylighting.

**Figure 12: The effect of envelope to volume ratio on energy efficiency**

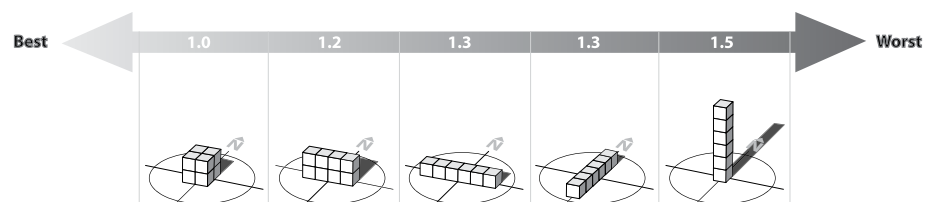

## 4.3 Landscape Considerations

### 4.3.1 Overview

Many landscape considerations happen very early on in the design process. Set backs, street trees, street alignment and use of landscape buffer zones can be guiding elements of many site planning decisions. Therefore, careful consideration of landscaping is critical to successfully implementing the passive approach at the early stages of design. The integration of landscape strategies

requires an active IDP where energy and thermal comfort goals are discussed and understood within the design team. Vegetation can help in many ways:

- Reducing ambient temperature and limiting the heat island effect around buildings, thus reducing the cooling load.
- Protecting the building from sun, wind and precipitation.
- Reducing solar intensity received by walls and roof by introducing vegetated 'green' roofs and walls.

### CASE STUDY

Turn to page 108 to learn how the new Butchart Gardens Carousel building will take advantage of its surrounding landscape.

Figure 13: Landscape strategies for passive solar heating and daylighting control

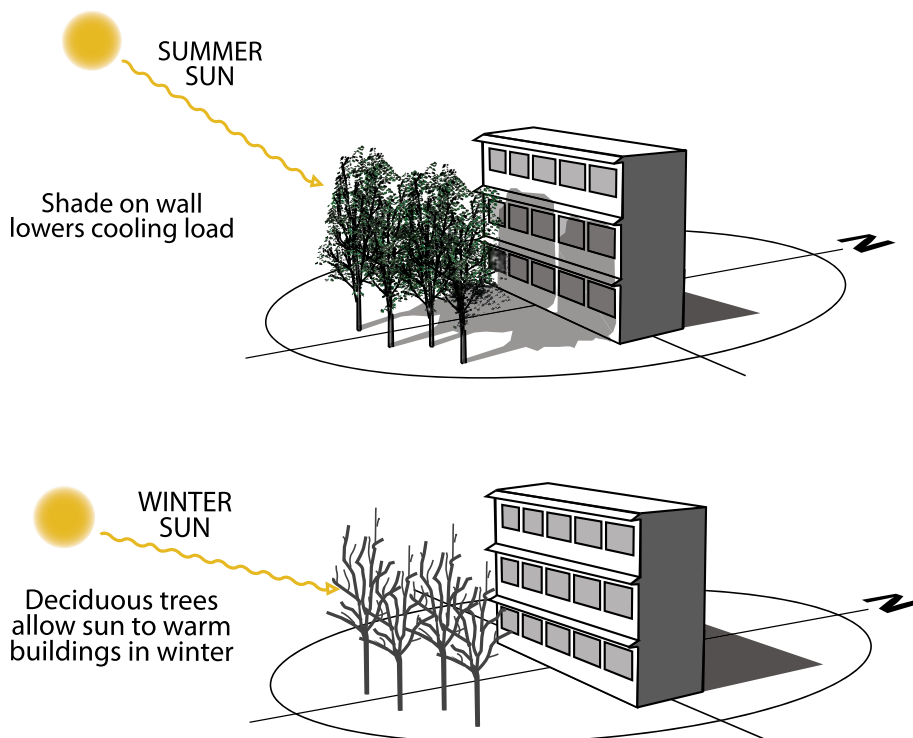

□ Deciduous trees provide cooling shade in the summer and after shedding their leaves allow for warm sun to enter the building in the winter.



**Figure 14: Reducing solar intensity with a green wall (Aquaquest at Vancouver Aquarium)**

#### **4.3.2 Benefits**

- Deciduous planting provides desirable shading during summer and allows desirable solar gains during winter while adding aesthetic appeal.
- See Synergies below.

#### **4.3.3 Limitations**

- Landscaping strategies are often limited by the available space.
- Many landscaping strategies require maintenance and irrigation.
- Incorporating landscaping strategies in higher buildings can be challenging due to maintenance and increasing challenges such as weight, wind pressure and irrigation.

#### **4.3.4 Synergies**

- Landscaping strategies can assist mechanical ventilation systems by contributing to ventilation air pre-cooling.
- Landscaping strategies can contribute to daylighting controls by reducing glare.
- Landscaping strategies can facilitate passive heating by allowing solar heat gain during winter and providing shade during summer.

#### **4.3.5 Vancouver Applications**

- Vancouver's mild, seasonal climate is very conducive to deciduous trees whose leaves provide desirable shading during summer and fall to allow desirable solar gains during winter.

## 4.4 Space Planning

### 4.4.1 Overview

Matching the program requirements with orientation and massing (building geometry) can further decrease energy use and increase thermal comfort. Building functions with particular thermal requirements should be placed in areas of the building that can provide those conditions (or come closest) without mechanical intervention. For example, computer labs or other rooms that have large internal heat gains and thus require mostly cooling should be placed on north or east-facing facades to minimize energy use from mechanical cooling.

By accounting for the thermal comfort requirements of a particular space use and matching them to suitable building characteristics, the design team can use passive design strategies to reduce building energy demand and maintain occupant comfort.

### 4.4.2 Benefits

- Locating spaces in their ideal thermal location in the building reduces mechanical heating and cooling energy by taking advantage of the building's natural thermal responses.
- Strategic space planning can reduce glare and improve comfort.

### 4.4.3 Limitations

- In many cases, such as residential units facing only one direction, it may be difficult to program the building to avoid having uses that will be negatively affected by solar gain.

### 4.4.4 Synergies

- Space planning considerations are directly linked to orientation and massing and the ability of the design team to provide, when possible, appropriate thermal conditions within the buildings.

### CASE STUDY

Turn to page 105 to learn how careful space planning helps Surrey's Revenue Canada building.

□ Locating spaces in their ideal thermal location in the building reduces mechanical heating and cooling energy.

Figure 15: Example of Strategic Space Planning

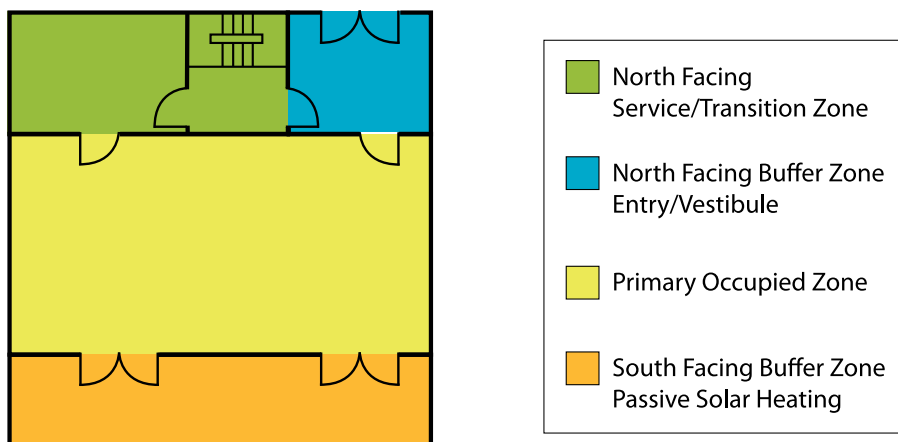

- When possible, incorporating buffer spaces to increase thermal conditions of the program areas should influence space planning decisions.

#### 4.4.5 Vancouver Applications



In the Vancouver climate, space planning should target the following conditions:

- Locate cooling dominant spaces on the north or in the centre of the building away from any perimeter solar gain.
- Locate heating dominant spaces on the south or west, avoiding over-exposure to west solar radiation.
- Locate residential spaces on the south exposure whenever possible.

### 4.5 Buffer Spaces

#### 4.5.1 Overview

Buffer spaces such as double facades and sunspaces are located along the building perimeter and can be occupied or unoccupied, as well as

semi-conditioned or unconditioned. They improve building energy performance by widening the range of outdoor temperatures in which thermal comfort can be maintained in the building with low mechanical energy consumption. Especially helpful during winter, buffer spaces create another insulation layer in front of the envelope, slowing the rate of heat loss between the outdoors and the indoor conditioned space. Ideally, they should be convertible to fully exterior space during summer to aid in ventilation and cooling of the adjoining occupied space.

Buffer spaces are a key component of many passive solar designs when they are oriented on the sunny side of the building.

South- and west-facing buffer spaces can be designed to act as occupied sunspaces, providing both passive solar heat gain and a functional occupied space. Sunspaces function like passive solar collectors, trapping solar gains like a greenhouse. Thermal storage is most effectively provided in the thermal mass of the floor and/or walls of the sunspace structure itself. Stored heat can either reach the building passively through the walls between the sunspace and the interior, or be distributed by an active mechanical system. The design and construction of sunspaces varies widely. In general, they can have open or closed ends, single or multiple slopes, and various arrangements of storage mass in the floor and walls.



**Figure 16: Examples of Possible Sunspace Configurations**

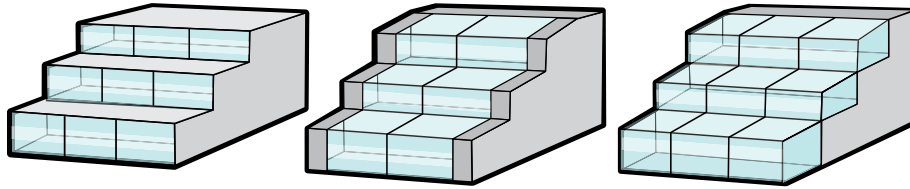

In passive heating applications, sunspaces must be designed so the solar gains are greater than the heat losses through the windows.

Integrating occupied buffer spaces as transition spaces is ideal because a wider thermal comfort range is acceptable in spaces like corridors and entryways, as opposed to other, more tightly conditioned spaces such as residential, classroom or office areas. Entryway vestibules, a mandatory requirement for many buildings under the Vancouver Building Bylaw, are also maintained at wider thermal comfort ranges, which also help to reduce the mechanical system energy consumption by limiting the loss of heated air during winter and cooled air during summer. They also improve comfort in the adjacent space by reducing or even eliminating drafts.

Unoccupied buffer spaces, such as double facades or Trombe walls, are cavities between an exterior window layer and a secondary wall or window layer, typically with controllable openings between the outdoors and the interior spaces. The openings are adjustable to either ventilate the cavity, or to transfer air between the indoors and outdoors. Double facades can

also be designed to induce stack effect and passively ventilate the occupied space. During winter the cavity can preheat ventilation air. During summer, the cavity openings can be adjusted to draw exhaust air out of the building. In the shoulder seasons, a double facade can increase the amount of time that natural ventilation can satisfy occupant comfort requirements.

#### **4.5.2 Benefits**

- Energy savings with reduced heat losses, infiltration at entries, and/or preheated ventilation air.
- Improved thermal comfort due to more stable interior space surface temperatures, reduced draft, and increased application of natural ventilation.
- Protects interior wall surface from the elements.
- Reduces building heating energy requirements via passive heating.

#### **4.5.3 Limitations**

- Buffer spaces increase the area of the building, but the space is not always usable for occupants.

- Buffer spaces may add FSR if exceeds zoning bylaw percentage.

#### 4.5.4 Synergies

Many synergies are possible with buffer spaces such as double ventilated facades. Buffer spaces in south facing double ventilated facades can be used to aid natural ventilation for example. Other passive building strategies can also work well with these types of facades such as night cooling and solar shading.

Vancouver's temperate climate makes buffer spaces an excellent design option, because they could potentially eliminate the need for mechanical cooling and dramatically reduce the amount of time the mechanical heating system operates. In addition, they can serve as seasonally convertible habitable spaces. Buffer spaces can also provide additional rain screen protection for the building envelope resulting in longer life and fewer moisture problems for the external wall assembly.

#### 4.5.5 Vancouver Applications

□ Buffer spaces create another insulation layer in front of the envelope.

Figure 17: Example of double facade as buffer space (summer performance)

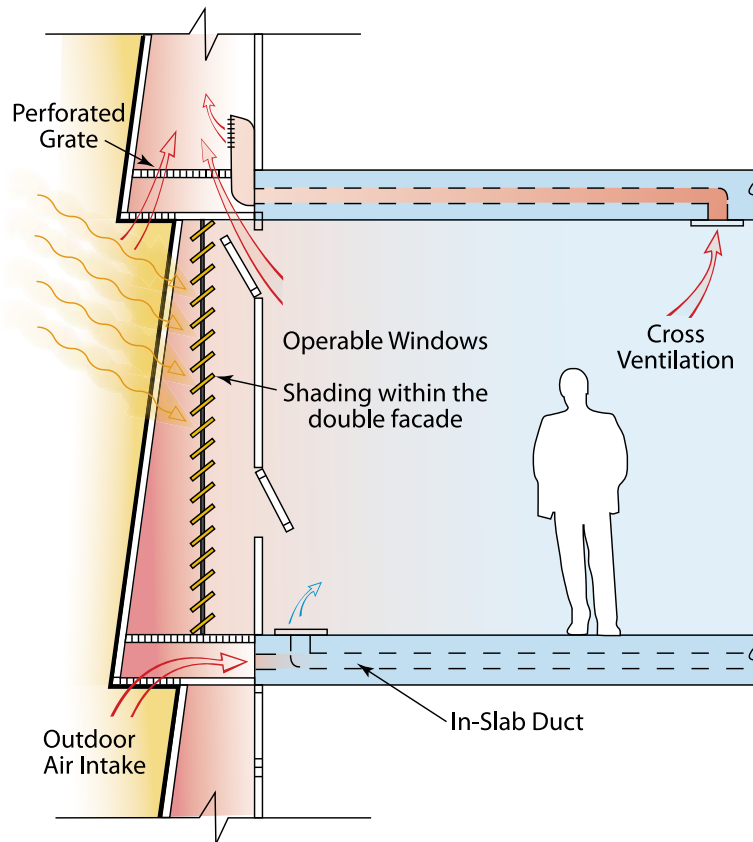

**Figure 18: Example of double facade as buffer space (winter performance)**

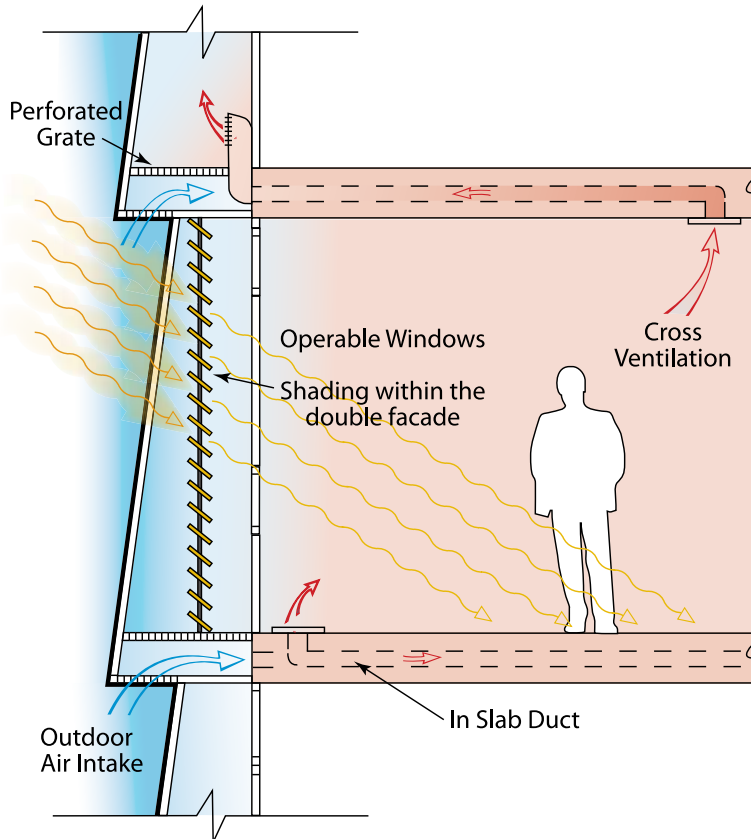

□ Window assemblies are the weakest thermal links in a building's insulated envelope.

## 4.6 Windows

### 4.6.1 Overview

Windows (glazing) are necessary envelope elements in any building as they provide access to views and daylight and can be used for natural ventilation. However, window assemblies are the weakest thermal links in a building's insulated envelope, and the window design approach has a significant impact on occupant thermal comfort and building energy consumption.

In general, windows affect a building's thermal state by

transmitting solar radiation directly into the conditioned space, where it stays trapped inside and heats the interior surfaces (i.e., the greenhouse effect). This heat gain is beneficial during winter and undesirable during summer when it can overheat the space.

With respect to windows, the design requirements of heating, cooling, aesthetics and daylighting often conflict; an energy efficient design uses window materials, sizes and framing design that balance aesthetics and overall energy performance. Annual building simulations can help to identify

### CASE STUDY

Turn to page 106 to learn how the White Rock Operations Centre uses different window to wall area ratios on different facades.

**Figure 19:  
Thermal Break**

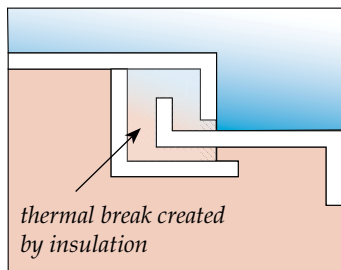

□ “Thermally broken” frames have an insulating spacer to slow the rate of heat transfer through the frame.

this optimal combination; however they cannot substitute for proper understanding of how window characteristics affect the building.

Window design characteristics fall into two categories: thermal and optical.

The thermal characteristics are the insulation or U-value, the framing type, overall area of windows, and the amount of framing.

- The number of panes of glass and the gas or vacuum void between them defines the amount of insulation provided by the windows, referred to as U-value. The U-value affects the amount of heat that is transferred between the interior and exterior, as well as the window interior surface temperature. Glass that insulates better traps more heat in the building and keeps a higher internal surface temperature, which is beneficial during winter and undesirable during summer.
- The overall window to wall area ratio is the window characteristic with the most significant impact on building energy consumption. Even the best performing glass insulates poorly when compared to an insulated wall. On east, south, and west exposures, greater window areas will admit more solar gain during winter. However, in the Vancouver climate, the net annual effect of any window to wall area ratio greater than 10% is still a thermal energy loss, even with the higher level of solar gains (see simulation results in Appendix E).
- Frames hold the glass panes and link them with the wall. They are usually made of highly conductive metal, creating thermal bridges between the interior conditioned space and the outdoors, further speeding heat loss through the window assembly. Frames can be made of less conductive materials, such as wood and vinyl. “Thermally broken” frames have an insulating spacer to slow the rate of heat transfer through the frame. However, even with a thermal break, frame material and design always limits the thermal performance of the overall window assembly. The minimum amount of framing structurally required is directly proportional to the area of windows; in addition to the minimal structural requirements, framing design is also guided by the envelope aesthetic, sometimes resulting in more framing than is necessary. The effects of thermal bridging should be minimized by reducing the amount of framing wherever possible. The thermal photo in Figure 20 demonstrates the effect of thermal bridging in window framing.

**Figure 20: Thermal Image Showing Thermal Bridging in Window Framing**

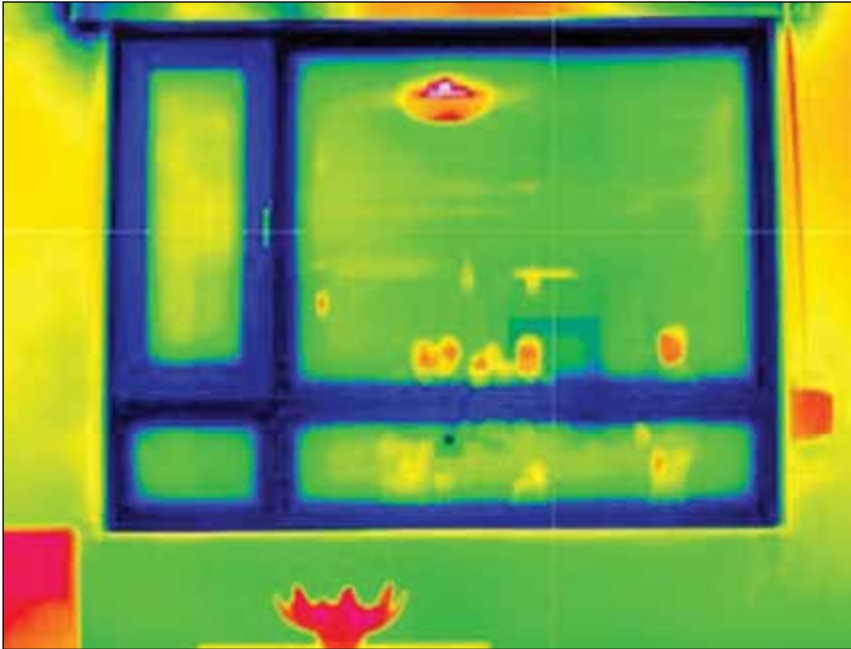

The optical characteristics of windows are defined by the glass material and the location of surface treatments such as coatings, tinting or colours. The overall optical performance of windows is typically described by the shading coefficient or solar heat gain coefficient, representing the amount of light and heat the window transmits, absorbs, and reflects. (A window with a low shading coefficient value blocks a high amount of solar radiation.) As these are fixed characteristics that can not be modified with the seasons, they have to strike a balance between the desirable shading during summer and the benefits of solar gains during winter.

The size, location, type and detailing of windows affects the thermal comfort and supplemental

heating and cooling energy consumed by the building. Therefore, window design must consider and balance the desire for floor to ceiling glass and the ongoing energy consumption that will be created by such window area and material characteristics.

### **Benefits**

- Good insulation values reduce heating energy consumption.
- Optimized shading properties reduce cooling loads in commercial building.
- Optimized insulation values and framing design reduce heat losses and condensation in residential and high-humidity applications (i.e. food preparation).



- Optimized window to wall area ratios result in greater levels of thermal comfort from smaller cold/hot surface areas.
- Optimized window to wall area ratios can reduce both heating and cooling energy demands.
- Smaller window areas make better quality windows more feasible economically.

### Limitations

- Higher capital cost of high performance glass.
- Window to wall area ratios of greater than 50% (including floor-to-ceiling glass) will greatly challenge the energy efficiency of a building. Buffer spaces should be explored in this design scenario.

### Synergies

- High performance windows should be combined with natural ventilation strategies to relieve heat gains.
- Window to wall area ratio impacts decisions on shading, window performance, thermal insulation, thermal mass, orientation and programming.

### Vancouver Applications

For residential buildings the most effective combination involves a double-pane window assembly with a low-e coating for good winter

performance in combination with external shading elements (rather than windows with a low shading coefficient) for good summer performance.

Commercial buildings with high internal heat gains will benefit from double pane windows with a low shading coefficient and a low-e coating.

From a building energy perspective, windows should be located to admit solar radiation during winter to aid the mechanical heating system and be designed to limit the amount of heat lost due to the poor insulating value of glass.

## 4.7 Solar Shading

### 4.7.1 Overview

Solar shading elements can be applied to the exterior or interior side of the windows.

External solar shading is the use of overhangs, blinds, louvers, trellises, or anything else that blocks the sun's rays from heating the building envelope and entering the building through windows.

Internal solar shading features, typically internal blinds, are any material that blocks the sun's rays at the perimeter but inside the building.

The distinction between internal and external shading is important because, although both systems block solar radiation, they have

### CASE STUDY

Turn to page 107 to learn how the Dockside Green development uses exterior solar shading.

different effects on the building aesthetic, day lighting, comfort, and building energy system requirements.

**External shading** devices intercept, absorb and/or reflect solar radiation before it reaches the exterior surface of the building envelope. When used in front of opaque envelope assemblies, external shading results in lower external surface temperatures and less heat gain through the envelope. When used on transparent envelope assemblies (i.e., windows), shading reduces the amount of direct solar gain in the space, reduces both the external and internal surface temperatures of affected windows, floors and walls, and reduces glare in the space.

**Internal shading** also blocks solar radiation from penetrating into the conditioned space; however the solar energy is still transmitted through the window assembly. Once inside, it heats the internal surface of the glass and the blinds. These warm surfaces will heat the interior space and occupants through radiant and convective heat transfer (i.e., greenhouse effect). If mechanical cooling is used, this heat gain needs to be removed by the system.

Effective shading design requires a balance between admitting desirable solar gains during winter and blocking undesirable solar gains during summer. The optimal shading strategy would be adjustable for different times

of the year. Fixed features such as horizontal overhangs are designed to admit low-angle winter sun and block high angle summer sun.

**Figure 21: Effects of Internal and External Shading**

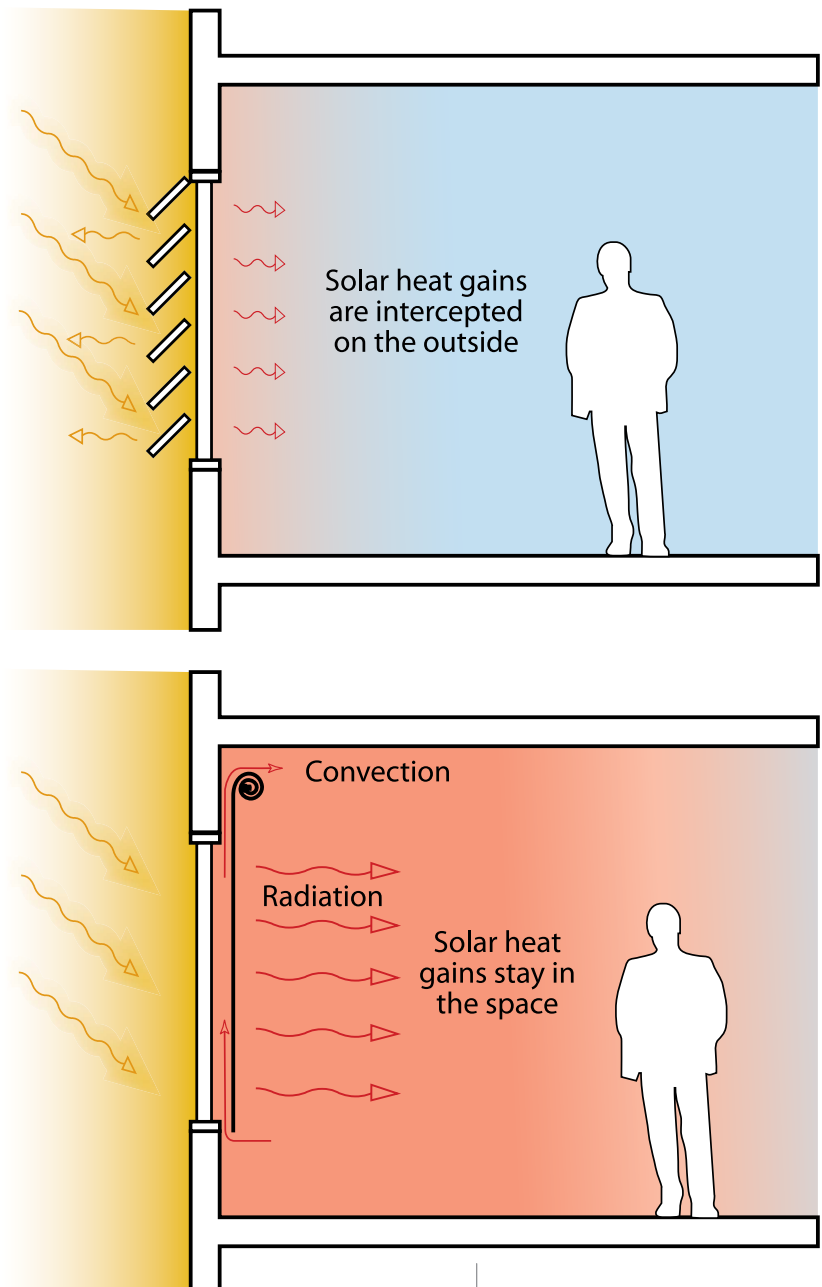

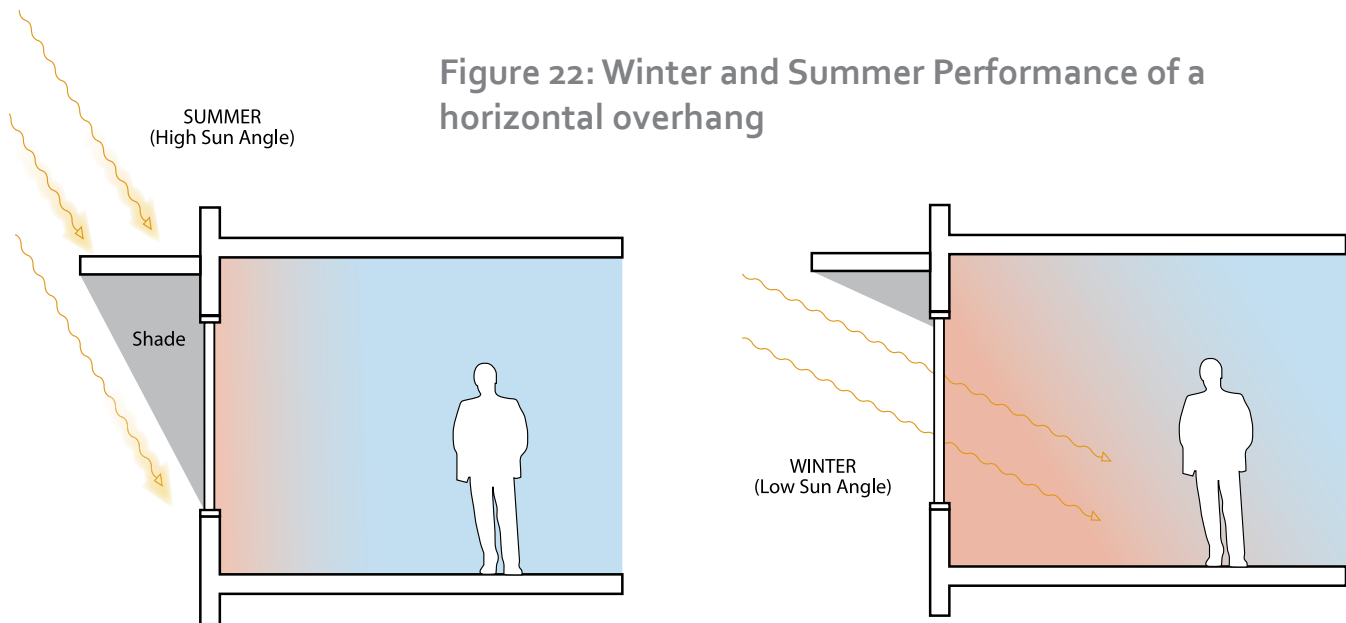

**Figure 22: Winter and Summer Performance of a horizontal overhang**

#### 4.7.2 Benefits

- Reduced demands on, and potentially eliminates the need for, active cooling systems.
- Reduced glare and improves thermal comfort by blocking direct solar gains.

#### 4.7.3 Limitations

- The benefit of blocking direct solar gains in summer must be balanced with the desired benefit of solar heat gains in winter.

- Designers must consider practical issues such as window washing.

#### 4.7.4 Synergies

- Building Orientation
- Daylighting

#### 4.7.5 Vancouver Applications

- Shading elements should be designed according to their particular facade orientation and keeping in mind seasonal temperature variations and the changing angle of the sun.
- When designing fixed shading devices, it is important to consider how they will provide the appropriate performance to meet both winter heating and summer shading/cooling requirements.

### 4.8 Thermal Mass

#### 4.8.1 Overview

All matter has thermal mass, however when used in reference to a building, thermal mass generally means materials capable of absorbing, holding, and gradually releasing heat (thermal energy). Thermally massive materials absorb

#### CASE STUDY

Turn to page 104 to learn how UBC's Liu Institute for Global Issues takes advantage of thermal mass.

heat and slowly release it when there is a temperature difference between the mass and the surrounding space. When incorporated in a wall, for example, the mass acts as a heat sink, absorbing the heat and slowing its transfer through the wall.

Heavy, dense building materials with high specific heat like stone, concrete, brick, or adobe have high thermal mass. Lightweight, porous materials such as wood, insulation, and glass have low thermal mass.

During summer, thermal mass exposed to the interior absorbs

heat from the space, including solar gains, and lowers the load on the mechanical cooling system. A thermally massive floor in a day-occupied building, for example, can be cooled overnight with cooler outdoor air. In the morning the cool mass will absorb solar and other heat gains from the space, providing the sensation of coolness from the floor. This has been shown to delay the onset of daily mechanical cooling and in some cases reduce or even eliminate the peak cooling demand. This delay is referred to as “thermal lag.”

□ Thermally massive materials absorb heat and slowly release it when there is a temperature difference between the mass and the surrounding space.

Figure 23: Effects of Thermal Mass

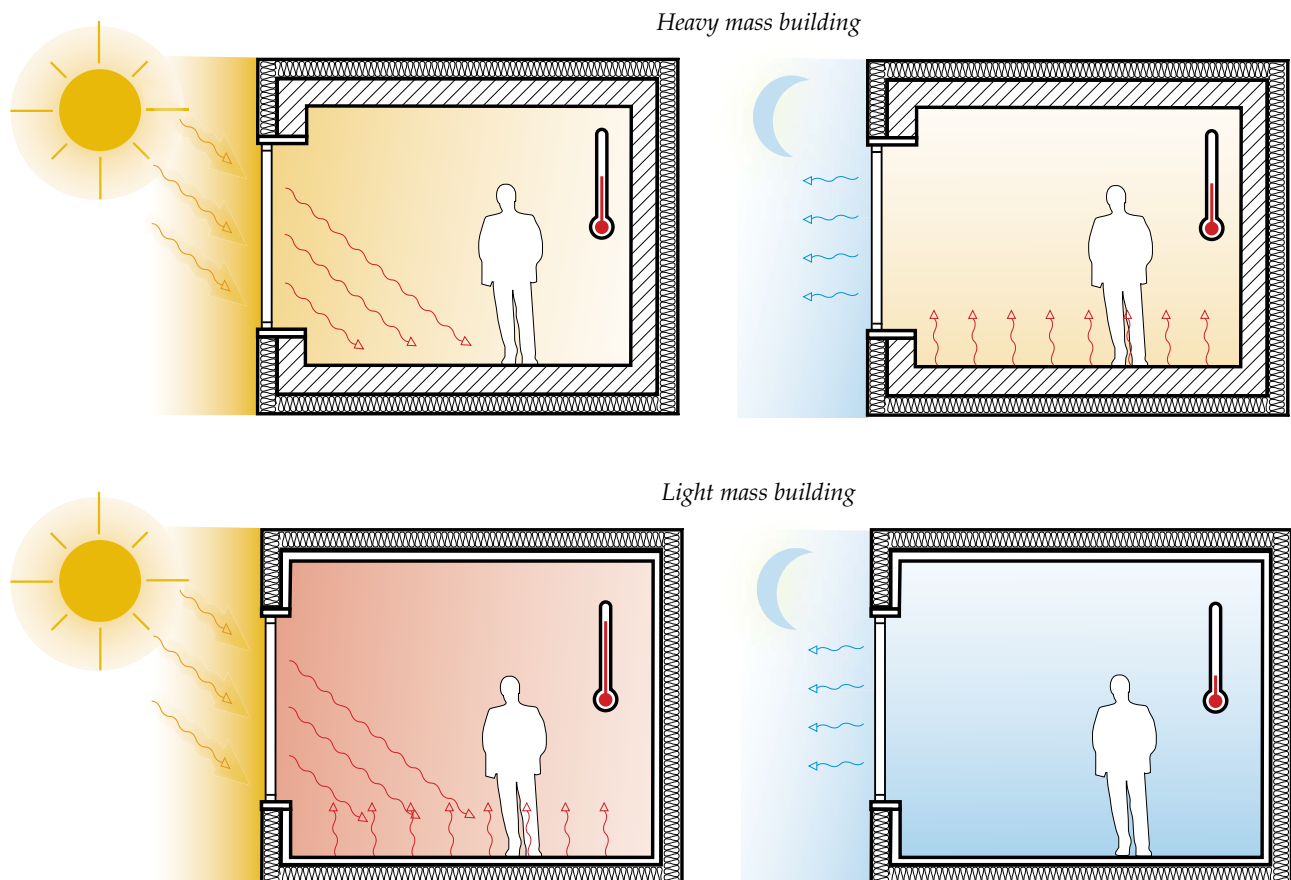

Thermal mass can have a negative impact on energy performance in some cases, where there is no opportunity to release heat into ambient air (in climates with no diurnal swing) or there is no opportunity for solar gains to be absorbed and stored (in climates with cold temperatures and low solar incidence).

#### 4.8.2 Benefits

- Reduced annual energy use.
- Reduced peak demand.
- Maintains a more stable internal environment.
- Increased acoustic insulation of assemblies.
- Improved fire ratings of assemblies.

#### 4.8.3 Limitations

- Without adequate direct solar radiation (i.e., on north-facing facades), thermal mass can result in increased energy consumption from the mechanical system when compared with lightweight construction.

#### 4.8.4 Synergies

- Passive solar heating.
- Passive ventilation.
- Passive cooling and shading.

#### 4.8.5 Vancouver Applications

- Thermal mass construction, when applied to the interior side of the insulation and exposed to the occupants and solar gains, will reduce heating energy requirements in the Vancouver climate.
- Thermal mass construction, when exposed to natural ventilation air flows and the occupants, will reduce cooling energy requirements in the Vancouver climate.
- Thermal mass can allow for natural, controlled moisture absorption and release in the Vancouver climate.

### 4.9 Thermal Insulation

#### 4.9.1 Overview

Thermally insulating materials are poor thermal conductors that slow the rate of heat losses and gains to and from the outside. Effective thermal insulation is one of the most critical design parameters of building envelope.

This reduction of heat transfer is expressed in terms of R-Value and U-Value. Minimum R-Values and maximum U-values for key building envelope components are prescribed by current ASHRAE 90.1 building energy standards.

Thermal insulation also impacts the surface temperature on the envelope interior, which directly

R-Value / U-Value
<p><b>R-Value:</b> <i>Thermal resistance</i></p> <p>How well the material slows down the transfer of thermal energy.</p>
<p><b>U-Value:</b> <i>Heat transfer rate</i></p> <p>The intensity of heat transfer through the material.</p>
<p><b><math>R \approx 1/U</math></b></p>



impacts thermal comfort. Interior envelope surface temperatures must remain high enough during winter to avoid condensation and maintain occupant comfort. Cold surface temperatures (i.e., windows) affect occupant comfort by both radiation and convection.

To achieve consistent thermal insulation of the building envelope, assemblies must be carefully detailed with continuous thermal breaks. Thermal breaks use non-conductive materials to separate conductive materials to avoid degrading the envelope's thermal insulation, a common problem called thermal bridging.

#### 4.9.2 Benefits

- Reduces heating and cooling losses/gains and energy consumption.
- More stable interior surface temperatures increases thermal stability in the conditioned spaces.

#### 4.9.3 Limitations

- Rate of diminishing returns, best investigated with building simulations.

#### 4.9.4 Synergies

- Infiltration and air tightness.
- Window performance.

#### 4.9.5 Vancouver Applications

- Thermal insulation must be better than the current standard (ASHRAE 90.1 v.2007) in order to maintain comfort with window to wall area ratios optimized for heating and cooling.
- Minimize thermal bridging to ensure the targeted overall R-values and U-values of envelope assemblies are achieved.

### 4.10 Air and Moisture Tightness

#### 4.10.1 Overview

The air and moisture tightness of a building's envelope is a critical factor in its thermal performance as well as its long-term durability. It is also indirectly related to the building's ventilation system.

Undesirable air movement through the envelope can occur in either direction: infiltration is movement of exterior air into the building, and exfiltration is leakage of interior air to the exterior. Infiltration and exfiltration can occur at the same time through different unintentional paths such as cracks around windows and doors, improperly sealed construction joints, or various services penetrating the envelope. They are caused by air pressure and temperature differences across the building envelope due to differences in air density between warm and cold air. Greater differences in pressure and temperature cause greater rates of infiltration and exfiltration.



Indoor air and outdoor air are not only different temperatures most of the time, but they also contain different amounts of moisture in the form of water vapour, which diffuses with the air. In the Vancouver climate this diffusion is predominantly from the warmer, more humid interior side (due to internal moisture gains) toward the cooler, less humid exterior side. If moisture is allowed to diffuse through the envelope, it will eventually reach the colder portion of the envelope assembly, where it will condense as the envelope temperature drops below the dew-point temperature (see Appendix C.2).

An incorrectly detailed building envelope with undesirable air and moisture diffusion typically has the following negative effects:

- Reduced thermal insulating value of the envelope resulting in excessive heat losses and increased heating energy requirements.
- Uncontrolled air and moisture exchange between the exterior and interior.
- Potential condensation within the envelope.

- Physical damage of the envelope components from condensation (e.g., corrosion of metals, rotting of wood).
- Potential occupant health impact associated with mildew and fungus growth resulting from the trapped moisture within the envelope.

To avoid these negative impacts, a building's envelope must be completely air- and moisture-tight. Depending on the envelope type, different approaches to achieve air and moisture tightness are required:

### 1. Lightweight envelope

For most conventional lightweight envelope assemblies (e.g., steel or wood frame), air and moisture tightness is best achieved by applying both a continuous vapour barrier on the interior side of the envelope, at or just behind the finished surface layer, and a continuous rain screen on the exterior face of the envelope with a narrow, vented air gap separating it from the insulation. This configuration keeps the moist air in the space and precipitation on the outside. (The interior moisture is removed by proper ventilation.) Provided the continuity of the vapour barrier and rain screen is achieved (by careful design and installation), the resulting envelope is completely air- and moisture-tight and thus avoids negative impacts such as the risk of condensation and reduced thermal insulation value.

**Figure 24: Air- and moisture-tight envelope (conventional, lightweight assembly)**

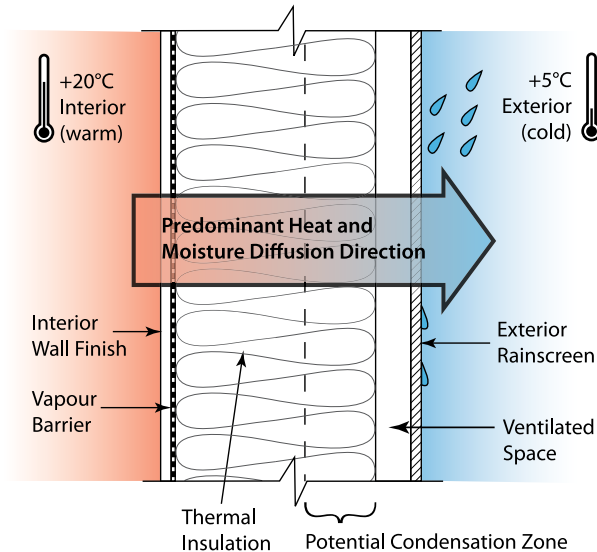

## 2. Heavy-weight envelope

High-performance heavy-weight envelopes should have “sandwich-like” assemblies with a relatively thick layer of concrete or masonry facing the interior and a layer of thermal insulation with a protective vented rain-screen facing the exterior. The dense and massive concrete or masonry layer is sufficiently air tight to keep infiltration and exfiltration at acceptable levels. Unless the interiors have consistently high humidity levels, as might be the case in a commercial kitchen, vapour barriers (e.g., waterproof coating, membrane, ceramic tile, etc.) on the interior surface may not be essential. As massive materials are also porous to a certain degree, they can absorb and release moisture from the indoor air. When combined with continuous exterior thermal insulation to keep the mass temperature above the dew point, the massive layer can absorb

and release moisture safely without risk of condensation and its related negative impacts. This continuous thermal insulation on the exterior side is critical to both improving energy performance and avoiding condensation. (Proper application of air and vapour barriers must be considered with a qualified building envelope consultant on a project-specific basis.)

Insulating heavy mass envelope from the inside requires a vapour barrier, since the potential condensation zone extends all the way to the insulation. Inside insulation also creates undesirable thermal bridges at floor-to-wall interfaces that are prone to condensation and compromise the thermal insulation value of the envelope.

Traditional non-tight envelopes had high infiltration/exfiltration rates (often more than 1 air change per

□ Buildings in Vancouver should have properly detailed and constructed air- and moisture-tight envelopes.

hour, or ACH) that were actually—and unintentionally—high enough to meet ventilation requirements. However, this undesirable, uncontrolled ventilation increased heating energy requirements and often caused condensation and its related negative impacts. Although in Vancouver’s mild climate the energy penalty for a non-tight envelope is not as severe as in the rest of Canada, uncontrolled air and moisture diffusion through the envelope is still undesirable. Properly designed and built air- and moisture-tight envelopes typically limit uncontrolled air exchange to less than 0.2 ACH. As a result, the space ventilation must be provided by separate means to provide sufficient fresh air for building occupants.

Space ventilation can be fully active with fans and heat recovery ventilation (HRV) units, fully passive with operable windows, or a mixed-mode system that combines the two. Most locations at Vancouver’s latitude have harsher climates with much greater heating-dominant requirements. In these climates, year-round reliance on fully active HRV is typically recommended as the most energy-efficient means of providing ventilation in air-tight buildings. However, in Vancouver’s milder climate, the most energy-efficient solution is the mixed-mode ventilation approach, relying on HRV during heating season only and relying on passive ventilation strategies for the rest of the year. (See Appendix E - Energy Modeling for modeling results that illustrate the greater efficiency of a mixed-mode system in the Vancouver climate.)

#### 4.10.2 Benefits

- A properly detailed and installed air- and moisture-tight envelope improves building energy performance and mitigates the risk of condensation and its related negative effects.

#### 4.10.3 Limitations

- Tighter envelopes require greater care to avoid leaks from face seals.
- An inadequately detailed and/or installed air- and moisture-tight envelope can result in cumulative moisture and condensation buildup within the envelope. This will result in compromised energy performance and other negative effects.

#### 4.10.4 Synergies

- Passive and mixed-mode ventilation strategies.
- Certain shading devices can also serve as additional rain protection for the envelope.

#### 4.10.5 Vancouver Applications

Buildings in Vancouver should have properly detailed and constructed air- and moisture-tight envelopes. Passively designed buildings should also incorporate a mixed-mode ventilation approach, relying on HRV during heating season only and relying on passive ventilation strategies for the rest of the year.

**City of Vancouver  
Passive Design Toolkit - Best Practices for Homes**

**Prepared by Light House Sustainable Building Centre  
and Dr. Guido Wimmers.**

**November 2008**

**Cover photo: courtesy of melis+melis+wimmers**



# Contents

<b>1. Introduction.....</b>	<b>1</b>
How to use this toolkit:.....	1
<b>2. Passive Solar Power.....</b>	<b>3</b>
2.1 Solar Access.....	4
2.2 Energy Efficiency and Thermal Comfort.....	5
<b>3. Orientation.....</b>	<b>7</b>
3.1 Building Shape.....	7
3.2 Ideal Elevations.....	8
3.3 Landscaping.....	10
<b>4. Interior Layout.....</b>	<b>13</b>
4.1 Kitchens.....	13
4.2 Living Spaces.....	13
4.3 Bedrooms.....	13
4.4 Mechanical Systems.....	13
<b>5. Insulation.....</b>	<b>15</b>
5.1 Insulation Materials.....	16
5.2 Selecting Insulation Materials.....	22
5.3 Airtightness.....	23
5.4 Thermal Bridges.....	23
5.5 Assemblies.....	24
<b>6. Windows (glazing).....</b>	<b>25</b>
6.1 Thermal Quality and Style of Window.....	25
6.2 Location and Size of Windows.....	28
6.3 Shading.....	28
<b>7. Lighting.....</b>	<b>31</b>
7.1 Interior Layout and Windows.....	31
7.2 Skylights vs. Solar Tubes.....	31
7.3 Clerestory Windows.....	31
7.4 Paint as a Passive Lighting Strategy.....	33
<b>8. Ventilation.....</b>	<b>35</b>

**Contents Continued...**

8.1 Window Placement..... 35  
8.2 Stack Effect and Cross Ventilation..... 35  
8.3 Window Style..... 36  
8.4 Heat Recovery Ventilators..... 36

**9. Thermal Mass..... 39**

9.2 Slab on Grade Construction ..... 40

**10. Density ..... 43**

**11. Benefits of Passive Design ..... 45**

Summary & Recommendations..... 46

**Bibliography..... 48**

**i. City of Vancouver Policy Context ..... 51**

Green Homes Program..... 51  
Part 3 Buildings ..... 52  
EcoDensity..... 52  
Climate Neutral Network ..... 53

**ii. Acronyms and terms used in this report ..... 54**

# 1. Introduction

This toolkit outlines passive design best practices for low-rise wood framed construction buildings in Vancouver.

## How to use this toolkit:

This toolkit has been written to inform City staff and the design and development communities about passive design. While covering best practices, the toolkit addresses the specific needs of Vancouver and outlines a succinct definition of what 'passive' means for Vancouver. This toolkit can be used as a reference for best practices, and considered complementary to design guidelines and policy.

The principles of passive design are not new and are, in fact, based on simple, proven concepts. Passive design refers to an approach that discourages reliance on mechanical systems for heating, cooling and lighting and instead harnesses naturally occurring phenomenon such as the power of the sun, direction of wind and other climatic effects to maintain consistent indoor temperatures and occupant comfort. By leveraging the natural environment, buildings that incorporate passive design can:

- help to reduce or even eliminate utility bills
- improve the comfort and quality of the interior environment
- reduce GHG emissions associated with heating, cooling, mechanical ventilation and lighting
- reduce the need for mechanical systems, thereby reducing the resources required to manufacture



these systems, as well as the costs associated with their purchase or operation

- make alternative energy systems viable

Homes designed using passive strategies do not have to look aesthetically different from those that are designed without consideration for climatic factors, but occupants of a passive home will experience greater thermal comfort while paying lower energy bills. The most rigorous European standard, PassivHaus, regulates input energy to a maximum 15 kWh / m<sup>2</sup>/ year for heating/cooling/ventilation – about one tenth of that in a typical new 200 m<sup>2</sup> Canadian house, and a difference equivalent to 300 litres of oil, 300m<sup>3</sup> of natural gas or 3000 kWh of electricity annually.

□ Homes designed using passive strategies do not have to look aesthetically different



□ A passive design can reduce total energy demand for space heating and cooling to less than 15 kWh / m<sup>2</sup> / year.

When approaching the design for a building, the following questions can be considered:

*'How important is occupant comfort for this building?'*

*'How important is occupant health in this building?'*

*'How important is the environmental footprint of the building?'*

*'How future proofed is the building design?'*

*'How will the building make use of natural climatic factors?'*

Passiv Haus is a specific design standard developed in Austria and Germany. A building that qualifies for this standard has to meet clearly defined criteria, which include (for a building constructed at Northern European latitude of 40-60°):

- A total energy demand for space heating and cooling of less than 15 kWh / m<sup>2</sup> / year
- A total primary energy use for all appliances, domestic hot water and space heating and cooling of less than 120 kWh / m<sup>2</sup> / year
- The total primary energy use includes the efficiency of the energy generating system

A Passiv Haus building shares common core features with other passive design buildings, relying on four common strategies:

- A high level of insulation, with minimal thermal bridges
- A high level of utilization of solar and internal gain
- A high level of air tightness (See Chapters 5.3 and 5.4 for a discussion on Thermal Bridges and Air Tightness)
- Good indoor air quality (which may be provided by a whole house mechanical ventilation system with highly efficient heat recovery)

The Passiv Haus approach was used extensively as a reference in developing this toolkit.

For further information on the Passiv Haus system please visit [www.passiv.de](http://www.passiv.de)

## 2. Passive Solar Power

The sun emits energy as electromagnetic radiation 24 hours per day, 365 days per year, at a rate equivalent to the energy of a 5725°C furnace. In fact, each year the sun can supply nearly 36,000 times the amount of energy currently provided by total world oil consumption.



The sun's energy is radiated to the earth in the form of visible light, along with infrared and ultra-violet radiation which are not visible to the naked eye. When this radiation strikes the earth's surface, it is absorbed and transferred into heat energy at which point passive heating occurs. The rate at which solar energy reaches a unit area at the earth is called the 'solar irradiance' or 'insolation'.

Vancouver has a 'moderate oceanic' climate and is classified as heating dominated. This means

that buildings require more days of heating than cooling. Fortunately, Vancouver does not experience extreme heat or cold conditions for long durations, making passive design less challenging. Even though Vancouver receives plenty of sun in the summer, it receives very little sun from November to March and is challenged to benefit greatly from passive winter solar gain (unlike cold and sunny Edmonton winters). Winter also sees early sunsets and late sunrises, while in the height of summer Vancouver experiences long daylight hours (up to 16.5 hours).



□ **Fortunately, Vancouver does not experience extreme heat or cold conditions for long durations, making passive design less challenging in this city.**

**Table 1: Solar Radiation**

Climate: Vancouver  
 Building: Kitsilano Residence

Interior Temperature: 20 C  
 Treated Floor Area: 208 m<sup>2</sup>

	Jan	Feb	Mar	Apr	May	Jun	Jul	Aug	Sep	Oct	Nov	Dec	Year
Heating Degree Hours - Exterior (kKh)	13.9	11.1	10.8	8.3	6	3.7	2.5	2.6	4.8	8.2	10.9	13.3	96
Heating Degree Hours - Ground (kKh)	6.4	6.2	6.7	5.9	5.2	2.9	2.2	1.8	2.9	3.7	4.4	5.6	54
Losses - Exterior (kWh)	1413	1130	1095	846	615	380	255	263	487	837	1115	1350	9787
Losses - Ground (kWh)	180	173	189	166	145	82	62	51	82	102	125	157	1515
Sum Spec. Losses (kWh/m <sup>3</sup> )	7.7	6.3	6.2	4.9	3.7	2.2	1.5	1.5	2.7	4.5	6	7.2	54.3
Solar Gains - North (kWh)	30	53	87	118	171	197	186	140	95	64	38	23	1202
Solar Gains - East (kWh)	1	2	4	5	7	7	8	7	5	3	1	1	52
Solar Gains - South (kWh)	311	438	600	559	652	588	640	692	680	507	300	231	6199
Solar Gains - West (kWh)	2	4	6	8	12	12	13	11	8	5	2	2	86
Solar Gains - Horiz. (kWh)	0	0	0	0	0	0	0	0	0	0	0	0	0
Solar Gains - Opaque (kWh)	21	39	76	105	155	162	167	138	94	52	24	15	1047
Internal Heat Gains (kWh)	367	331	367	355	367	355	367	367	355	367	355	367	4318
Sum Spec. Gains Solar + Internal (kWh/m <sup>3</sup> )	3.5	4.2	5.5	5.5	6.6	6.4	6.6	6.5	5.9	4.8	3.5	3.1	62
Utilisation Factor (kWh)	100%	98%	92%	81%	55%	35%	23%	23%	46%	85%	99%	100%	63%
Annual Heat Demand (kWh)	863	453	234	77	6	0	0	0	1	94	526	871	3125
Spec. Heat Demand (kWh/m <sup>3</sup> )	4.1	2.2	1.1	0.4	0	0	0	0	0	0.5	2.5	4.2	15

A 150m<sup>2</sup> passively designed house (2 storey) would need 15 kWh/m<sup>2</sup>/year or less for heating. This is 150 m<sup>2</sup> x 15kWh = 2250 kWh in total per year for heating. The roof area of this home would be 75 m<sup>2</sup>. 75 m<sup>2</sup> x 0.78 (solar radiation) x 31 December days = 1800 kWh. Theoretically the energy from the sun given in December would be almost enough for the whole year!

### 2.1 Solar Access

Due to the low levels of solar exposure, passive design should include a combination of solar heating with passive cooling and shading in the Vancouver climate.

In consideration of Vancouver’s climate, this toolkit will focus on maximizing solar gains in winter, and will include some recommendations for avoiding unwanted solar gain in the summer.

Solar access describes the amount of useful sunshine reaching a building. This value varies depending on climate, and can be impacted by the location of the sun and surfaces which surround a building.

The angle at which the sun strikes a location is represented by the terms *altitude* and *azimuth*. Altitude is the vertical angle in the sky (sometimes



referred to as the height); azimuth is the horizontal direction from which it comes (often referred to as the bearing). Altitude angles can vary from  $0^\circ$  (horizontal) to  $90^\circ$  (vertically overhead). Azimuth is generally measured clockwise from north so that due east is  $90^\circ$ , south  $180^\circ$  and west  $270^\circ$ .

### Altitude and Azimuth

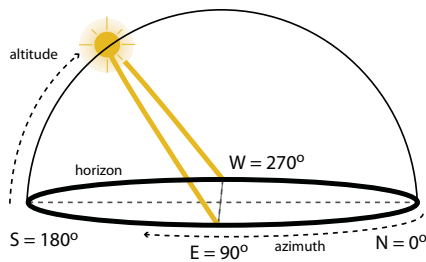

As solar radiation strikes the earth, it is reflected by surrounding surfaces. This is called reflected radiation. Light coloured surfaces reflect more than dark ones.

It is important to understand the pattern of the sun in relation to specific latitudes. A sun chart is the simplest way to determine where the sun is at specific dates and times throughout the year. In order to better determine solar access, there are also computer programs which can manipulate data from charts and formulas.

## 2.2 Energy Efficiency and Thermal Comfort

Though comfort can be highly subjective, The American Society of Heating Refrigeration and Air-Conditioning Engineers (ASHRAE) defines thermal comfort as the state of

mind that expresses satisfaction with the surrounding environment (ASHRAE Standard 55), and in this application, thermal comfort is achieved within a narrow range of conditions.

Factors such as temperature, ventilation, humidity and radiant energy affect thermal comfort, and for humans the comfort zone is within a very narrow range of conditions. Exterior climate conditions can also alter the acceptable interior conditions.

Building occupants are most comfortable when given the opportunity to adapt or have control over their environments (when they can open a window, put on a sweater, pull down the window blinds). Energy efficiency is achieved when occupant comfort is maintained through limited reliance on mechanical space conditioning. Thermal comfort rating software can model the amount of energy required to maintain comfortable temperatures within a building to size mechanical systems appropriately.

### Sun Chart

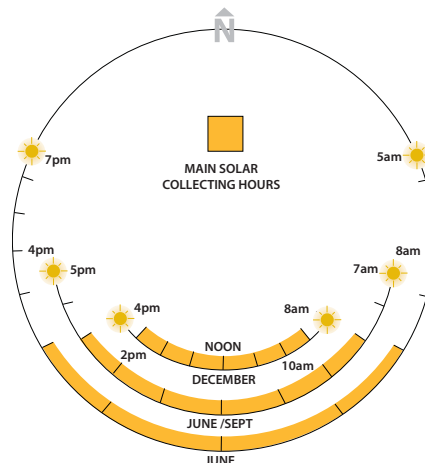

Solar access describes the amount of useful sunshine reaching a building.

### Dark and light surfaces

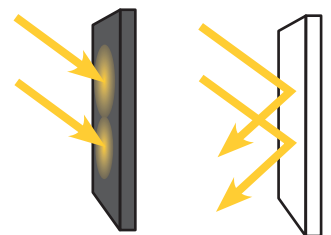

Light coloured surfaces reflect more than dark ones.



photo:melis+melis+wimmers

□ Energy efficiency is achieved when occupant comfort is maintained through limited reliance on mechanical space conditioning.

### Passive Solar Power

By planning for passive design, we can reduce the energy requirements of our built environment and improve thermal comfort for occupants. Passive design is not a new concept – ancient and medieval construction practices used abundant natural climatic conditions to passively control indoor temperatures.

#### Synergies/Barriers:

Designing for passive gains needs to be done keeping in mind best practices in construction – if a building is more air tight and leaks less energy, it must also be properly ventilated. If a building is to gain from south facing windows in the winter, it must also be shaded from the sun in the summer.

## 3. Orientation

Good building orientation in relation to the earth's axis and a site's geographical features can improve passive gains and thereby reduce the need for mechanical heating or cooling systems. This can also result in lower energy bills, and lower related GHG emissions.

Sites which are aligned along an east-west axis are ideal, as they receive good solar access while neighbouring houses provide protection from the eastern and western sun in the summer.

Broadly speaking, homeowners may have little or no control over optimizing site selection and orientation; the former depending on availability of property or land and the latter determined by municipal zoning. For instance, in Vancouver and many North American cities, a grid-oriented system predominates and in Vancouver the majority of homes are oriented north-south on east-west streets.

Still, small shifts in decisions around orientation, based on climatic and regional conditions, can help to optimize passive gains and maximize use of the free energy generated by the local environment.

### 3.1 Building Shape

To maximize the benefits of passive design, a design must first and foremost minimize overall energy consumption requirements. A building design which keeps corners and joints to a minimum reduces the possibility of creating thermal bridges through which heat can dissipate to the outside of a building (see discussion in Chapter 5.4, thermal bridges).

Inefficient layout

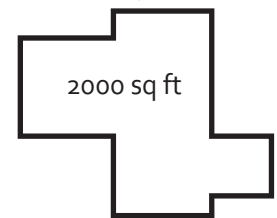

Efficient layout

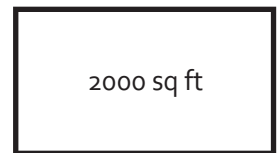

Complex layouts lead to more corners and joints which leak energy. It also creates more surface areas which can lose heat

### Vancouver's Street Grid



□ In Vancouver the majority of homes (both house and condominiums) are oriented north-south on east-west streets.

Compactness is a measure of floor space relative to building envelope area. A compact design maximizes living space within a minimum envelope area. The envelope or shell of the building is where heat loss occurs. Restricting the number of exterior walls also ensures that the amount of wall exposed to the elements is kept to a minimum. In an ideal case, a building design will seek to maximize the ratio of usable floor area to the outside wall area (including the roof). The theoretical ideal form would be a sphere, because this is a maximized volume versus a minimum envelope. The next most usable form would be a cube, with every permutation from the ideal a step towards weakening the theoretical performance of the building.

Single family homes are usually not as high as they are wide or long. This varies from the ideal, thus major prominences and offsets should be avoided. These not only

increase the envelope surface, but also lead to creation of heat bridges and are harder to maintain. Rowhouses and townhouses are another form of design which achieve maximum floor area and minimize opportunities for heat loss.

- Utilize a compact design in order to minimize exterior wall surface area and associated heat gain/loss potential
- A shape as close to a square as possible is optimum to minimize corners and maximize floor area in relation to outside wall area

### 3.2 Ideal Elevations

Orientation can affect the angle at which the sun enters windows, causing overheating in the summer. Attention to overhangs can be useful when a building is poorly oriented. Building homes side by side and to the property line will also affect orientation considerations.

The angle of solar radiation as it enters a window (angle of incidence) will affect the degree of passive solar gain that radiation delivers.

When the sun is low in the sky, the light hits the window perpendicular to the glass. In this case, the heat gain is at a maximum. As the sun is higher in the sky, the angle is increased, reflecting more of the light. In this instance, less heat is transferred to the building. Windows on the south elevation can generally best exploit the sun.

### Ideal Orientation

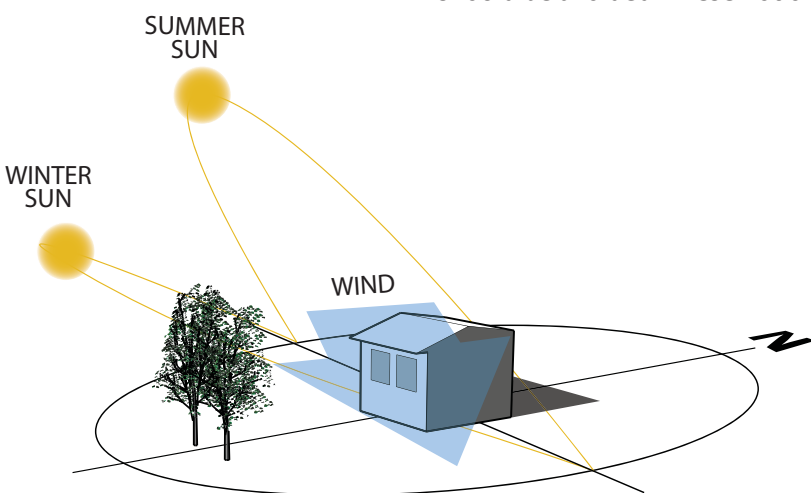

South facing windows allow for winter heat while strategically placed deciduous trees and overhangs will shade the hot summer sun. Neighbouring properties can effect solar access and wind pattern.



## Southern elevation

To maximize the potential for solar gain through the winter months, a building should orient the longest elevation towards the south. (In design terms, south is considered to be anywhere within 30° east or west of true south.)

In addition, to reduce unwanted solar gain in the summer, designing for flexible sunscreens or overhangs for windows on these south facing elevations will ensure that the sun can be shaded during the warmer months.

Fixed overhangs should be designed to have a depth of roughly 50% of the height from the glass to the tip of the overhang. As the sun in summer is higher than in winter along the south elevation, a properly sized overhang can shade a south window for most of a summer day, without blocking out the low angled winter sun.

## Overhang

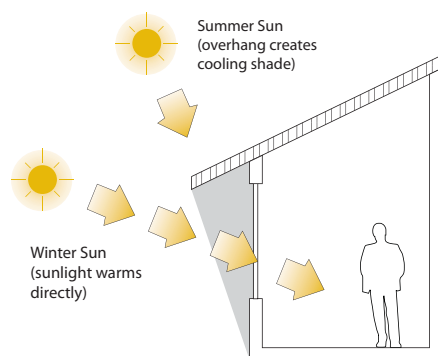

Because the winter sun is at a lower angle, sun can travel directly into the building warming it during the cool months. The high summer sun is blocked by the overhang creating a cooling shade.

- Maximize the window area on the south elevation
- Avoid winter shadows from coniferous trees, other buildings, or other obstacles that will create shadows during the short winter days

## Eastern and Western Elevations

To reduce unnecessary solar gain in the summer, a design should minimize window or wall area facing east or west.

Windows on the east elevation are exposed to solar gain throughout the year, while west facing windows will provide too much solar gain in the summer and insignificant gains in the winter.

At the same time, cold winter winds coming primarily from the east should also be taken into consideration.

- East facing windows should be limited in size, or protected by overhangs or trees
- West facing windows should be avoided unless they can be fully shaded during the summer months
- Planting deciduous trees on the east and west sides will shade the home in the summer, and allow winter light in when they drop their leaves
- The majority of residential lots in Vancouver are oriented such that the east and west facades are shaded by



□ A properly sized overhang can shade a south window for most of a summer day, without blocking out the low angled winter sun

□ Green roofs serve to moderate internal building temperature as well as to mitigate heat island effect. A study by the City of Toronto found that green roofs provide significant economic benefits in the areas of stormwater management and reduction of heat island (and the energy use associated with them). <http://www.toronto.ca/greenroofs/findings.htm>

There are several types of green roof systems, and many do not use new technology. Any green roof should be installed and maintained with care, and it is highly critical that a structural analysis of the building be completed prior to installation.



neighbouring houses.

- Landscaping with evergreen trees or tall hedges can help provide a windbreak

#### Northern Elevation

The north elevation provides the highest quality of daylight – diffused natural light.

- Design wall areas as primarily solid, with windows located where needed for daylighting and ventilation requirements
- Protect and insulate this elevation to prevent unwanted winter heat losses
- Take advantage of adjacent buildings to protect the building from heat losses

### 3.3 Landscaping

Landscaping can aid passive design strategies

- Plant shade trees in the appropriate locations to block or filter harsh winds
- Vegetation that blocks winter sun should be pruned, deciduous trees should be planted as they shed their leaves in winter, allowing in the sun
- Balconies on the south, if designed incorrectly, can restrict access to the winter sun
- Deciduous vines in combination with overhangs can provide self adjusting shading. Vines on walls can also provide summer insulation but this strategy is complicated as vines can also compromise the building envelope
- Plants can be used instead of paving to mitigate heat island effect in the summer



### Key Design Strategies

- Orient the “main” side towards the south ± 30° East or West, and use large south-facing windows
- Keep east, north and west window space small, while also using fewer windows in total (see discussion under windows, chapter 6)
- Minimize unwanted shade to allow passive solar energy use
- Use landscaping consistent with required amounts of shading at different times of the year – deciduous trees will offer shade in summer but access to solar heat in winter
- Use a compact building form to limit heat loss
- Provide operable windows on all building elevations
- Row and multi-story building designs can maximize efficiencies



□ Deciduous trees provide cooling shade in the summer and, after shedding their leaves, allow for warm sun to enter the building in the winter

### Orientation:

Cost: \$\$\$\$

Ideal building orientation may be constrained by municipal planning layout requirements. A building can still use passive design strategies through careful consideration of the placement of windows and the design features used for shading and ventilation.

#### Synergies/Barriers:

As orientation is dictated by municipal planning, design becomes an important consideration – building design should acknowledge site limitations and compensate for them.

#### Impact on Energy Efficiency:

Even small changes in orientation and attention to details such as overhangs can be very effective.

## 4. Interior Layout

Good interior layout will facilitate many of the passive strategies recommended in this toolkit, in particular thermal mass, lighting and ventilation considerations.

Before deciding on interior layout, consider the following questions:

*Which are the most frequently used rooms?*

*What are the lighting needs for each room?*

*What is the external shading situation?*

### 4.1 Kitchens

Kitchens should ideally be located within the building in such a way as to avoid over-heating, either the kitchen itself or the rest of the building. One way to ensure this is to avoid placing kitchens on the western elevation. In most instances, this will cause over-heating in the warm summer months. An ideal location for a kitchen is on the eastern side of the building. This catches the morning sun but not the warmer, late afternoon sun. Northern elevations or central spaces within the building are also ideal for kitchens that are heavily used, though kitchens in central spaces need to ensure appropriate ventilation.

- Situate the kitchen on the eastern or northern elevation, or in a central space within the building

### 4.2 Living Spaces

Rooms that are occupied predominantly in the evening

should be located on the western side of the building, in order to take advantage of the evening sun. Frequently used rooms (such as a home office, or the living or dining rooms of a residential building), should be located on the southern side where they can be warmed by sunlight throughout the day.

- Situate evening-use rooms on the west elevation
- Situate frequent-use rooms on the south elevation

### 4.3 Bedrooms

Bedrooms generally require less heat. Decisions for the location of bedrooms can largely be based on aesthetics and occupant or designer preferences in addition to thermal comfort considerations. Ideally, windows should be kept to a minimum and should allow for passive ventilation (see discussion under Ventilation, Section 8).

- Situate bedrooms as comfort dictates

### 4.4 Mechanical Systems

Similar mechanical and plumbing equipment should be grouped within close proximity of each other. This minimizes inefficiencies in piping or heat loss due to unnecessarily long lines and also



□ Rooms that are occupied predominantly in the evening should be located on the western side of the building, in order to take advantage of the evening sun.



Temperature sensors should not be situated in the northern part of a building. This area is generally cooler and sensors may detect cold even though the southern part of the building is receiving solar gain. A good passive design strategy would be to attempt to distribute this heat to the cooler parts of the house (see Chapter 9).

economizes on space dedicated to mechanical uses.

Bathrooms, kitchens and laundry rooms should be placed above or adjacent to each other, so that efficiencies of the plumbing system can be maximized.

Minimize the building footprint by using short pipe runs (hot/cold water or sewage) and ventilation ducts

Place thermostats with due consideration to temperature variances within the building (see sidebar)

### Ideal Floor Plan

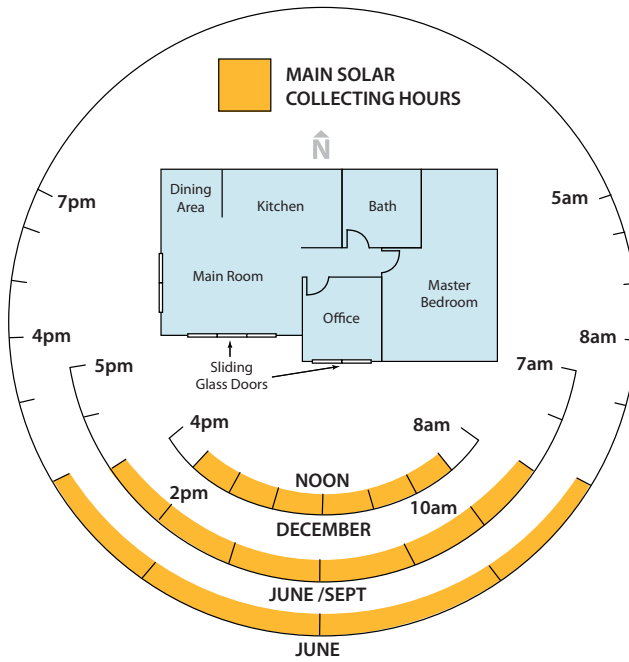

#### Interior Layout:

Cost: \$\$\$\$\$ - \$\$\$\$\$

Good interior layout can assist greatly with passive heating and cooling, with particular opportunities for efficient daylighting.

#### Synergies/Barriers:

Layout decisions should incorporate other building elements and work in harmony with them, such as the windows and mechanical systems.

#### Impact on Energy Efficiency:

Good interior layout can off-set later energy consumption by reducing need for light and heat.

# 5. Insulation

In the world of outdoor clothing, breathable fabrics and super insulated linings work with highly detailed seams and closures to keep out wind, water and cold. Sound building envelope design can similarly moderate these conditions.

Minimum insulation requirements are currently embedded in the BC Building Code as well as the City of Vancouver Building By-laws. These can be prescriptive in nature (e.g. 'install R12 insulation'). However, the City of Vancouver and the new provincial building code are moving towards a performance, rather than prescriptive, path. Beyond a certain thickness, there is minimal increase in performance and attention must be paid to the airtightness of the construction. The performance path, which measures the overall energy performance of a construction, is a more accurate way to ensure that a building performs as intended.

For example, the EnerGuide rating system uses a blower door test to measure airtightness. Energy modeling, such as with EE4 software available from Natural Resources Canada, can predict the energy usage of a building. These approaches are more likely to ensure a particular level of performance, rather than specifying insulation values without then confirming that installation of specific insulation is actually delivering better performance.

Appropriate insulation can mitigate heat loss (or gain), while also eliminating the uncomfortable effects of unwanted radiant energy from warm surfaces in summer or cold surfaces in winter. To do this effectively, envelope design should be climate appropriate.

Insulation is arguably the most critical determinant of energy savings and interior thermal comfort, though good insulation should not preclude consideration of air tightness, heat bridges and appropriate windows. An increase in the number of windows or doors decreases a building's performance

(see discussion under Chapter 6, Windows).

Among the questions to be asking when making insulation decisions and selecting materials are:

*What is climate-appropriate insulation for this building?*

*What are the environmental considerations of the material selected?*

*Are there other benefits of the material besides insulation?*

*How will the design of the building be airtight?*

## Heat Loss

Insulated

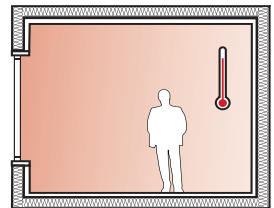

No Insulation

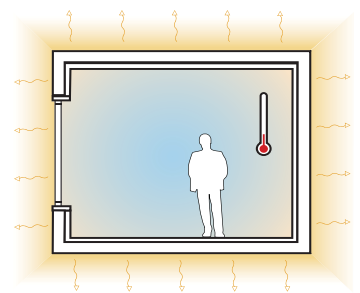

Heat exits a non-insulated building quickly thus requiring more heating resources to keep a room comfortable.



□ Insulation materials can be categorized into organic or inorganic, renewable or non-renewable, or they can be listed by consistency, such as foam or rigid, wool or loose.

### Thermal Resistance

The thermal resistances of insulation materials will contribute to indoor surface temperatures of a building's exterior walls and thereby the internal thermal comfort. High thermal resistance indicates good insulating qualities. Resistance is in turn influenced by the temperature difference between inside and outside, the conductivity of the insulation used, and the thickness of this material.

Temperature difference is an external factor, while thickness and conductivity are determined by the choice of insulation material. Lower conductivity and greater thickness both reduce heat flow.

R-values are a measure of a material's resistance to heat flow, and are therefore an indicator of a material's insulation properties. On the other hand, U-values are a measure of the amount of heat that escapes a surface. In the case of windows, the glass does not act as an insulation material, and therefore measurement of R-value is not appropriate, and we use U-values instead.

$$R=1/U$$

The higher the R-value, the better insulation qualities displayed by the material. The lower the U-value, the better performance of a window against allowing heat or cold to pass through it.

## 5.1 Insulation Materials

Over the lifespan of a building, insulation will always have a positive environmental impact by reducing operating energy. However, the ecological footprint of the material itself should also be taken into consideration. This is complicated to define because there are a lot of different factors to be considered. Insulation can also have a bearing on indoor environmental quality depending on the materials selected, and can have implications for airtightness.

Classification of insulation is not straightforward as there are several systems to differentiate between materials. Materials can be categorized as organic or inorganic; renewable or non-renewable; or they can be listed by consistency, such as foam, rigid, wool or loose.

### Examples of insulating materials (all available locally):

#### *Conventional Insulating Materials*

##### *Fibreglass*

Fibreglass in one of its two forms (loose or batts), remains the industry standard in North America. Most fibreglass insulation now contains some recycled content, and some manufacturers have replaced the traditional-but-toxic phenol formaldehyde binder with other more benign alternatives – or no binder is used at all.

Loose fill, a type of fibreglass insulation which is small and fluffy and blown into place, is associated with black mould and health hazards similar to those associated with asbestos such as lung disease. On the other hand, fibreglass



batts are considered to have little or no negative impact on indoor environmental quality.

### *Spray applied foam*



Sprayed foam insulation is used in some higher performance residential buildings. It allows for continuity of insulation as insulation is sprayed when in liquid form, and then expands to fill the cavity – including the smallest cracks. Performance is not as prone to installation errors.

Products range from those with a high content of toxic substances, to those that are water-blown and do not off gas.

### *Rigid Polystyrene*

This product displays fairly high R-Values (RSI-Values) and is durable as well as relatively affordable.

There are, however, issues with CFC's and other hazardous substances that go into the production of polystyrene panels. Furthermore, this material is a derivative of crude oil, and therefore displays a large carbon footprint.

Some polystyrene products do not off-gas, and of the two main types of rigid polystyrene (extruded or XPS, and expanded or EPS) EPS is the more environmentally benign.

### *Aerogels*



Aerogels are a form of frozen silica smoke with extremely small pores, making this material extremely durable and light with incredible insulation values. Many are also translucent – and can be used to insulate windows and skylights or create translucent walls.

However, this is a very new material and testing is indicating that silica foam has similar detrimental health effects to fiberglass and asbestos; microscopic particles can break off and lodge in skin or lungs. Use of aerogels is not very common.

### *Mineral Wool*

In industrial and commercial construction, mineral wool remains popular for its fire resistance, though extraction and processing of mineral wool (a by product of steel processing) may still be an environmental concern.



□ Many aerogels are translucent – and can be used to insulate windows and skylights or create translucent walls.



□ **Natural cotton insulation made from recycled or waste denim**

***Natural Insulating Materials***

*Cellulose fibre*

Among commercially available natural materials, cellulose fibre (usually recycled newsprint), is gaining popularity.

Spray applied cellulose fibre is quite dense and provides a good barrier against air infiltration from the outside. Due to the spray in nature of the installation, performance is less likely to suffer from installation errors.

*Cotton insulation*

Cotton insulation made from recycled or waste denim is easy to install and does not off-gas.

*Sheep's wool*

Wool has been made into warm clothing for centuries but only now

is its excellent insulating quality being applied to building structures.

*Wood fibre*

Waste wood fibre panels, of varying densities, are a popular insulation material for PassivHaus buildings in Europe. With a small ecological footprint this material also provides sound reduction and high thermal mass.

*Straw bales, hemp or flax*

First used to construct homes by settlers of Nebraska in the late 1800s, straw bale homes offer an insulation value of more than double that of standard frame homes. It's considered a very environmentally friendly building form, as it comes from a quickly renewable source and reduces the need for framing lumber and plastic barriers.

Table 2 – Insulation Comparison Chart

Insulation Material	Common Application	Environmental Impact	IAQ impact	Typical R Value per inch	Other Considerations	Cost Effectiveness (\$-\$-\$-\$-\$)
Fibreglass Batt	Typically between floor or ceiling joists or wall studs	Some brands have up to 40% recycled content and have eliminated use of toxic binders, i.e. Formaldehyde-free Made from material with abundant supply	If non-toxic binders used then harmless. Respirator or certified dust mask to protect the lungs and long sleeve garments and gloves to protect the skin should be worn when working with fibreglass	3.6	Low moisture absorption Fire resistant with low flame spread rating (non-faced only) Does not absorb or retain moisture Little or no settling Ease on installation (placement and cutting for irregular spaces) Does not attract insects Insulation value decreases when wet	\$
Fibreglass blown or poured	Typically between floor or ceiling joists (horizontally) where there will be no traffic (i.e. attic), can be used in wall studs (vertically) but installation may be restricted due to wall blocking, nails, cables, etc. In horizontal applications it is excellent at leaving no gaps.  Will require small holes to be blown into wall cavities	Some brands have up to 25% recycled content and have eliminated use of toxic binders, i.e. Formaldehyde-free	If non-toxic binders used then harmless. Respirator or certified dust mask to protect the lungs and long sleeve garments and gloves to protect the skin should be worn when working with fibreglass	2.9	Low moisture absorption Fire resistant with low flame spread rating Does not absorb or retain moisture Little or no settling Better insulation coverage when dealing with irregular spaces, ceiling protrusions, hard to reach spaces, etc. as it creates a blanket over everything Requires a professional to install Must ensure it does not block attic venting when blown in	\$\$
Spray Polyurethane Foam	Can be used anywhere insulation is required, vertically or horizontally. Very good for situations where batt or board insulation is hard to attach, i.e. floor rim joists, lintels, etc. Can also be applied just as a base layer and then topped with batt insulation to save costs	Contains a minimum of 5% recycled content Can be up to 33% soy-based HFC blowing agents replaced with HFCs, carbon dioxide or water and do not harm the ozone layer Can create a fair amount of waste (face shavings in stud cavity) Not recyclable	Once the spray has cured (generally after 24 hours) the components are inert and do not effect IAQ	7	No settling Can be used as an air barrier but not a vapour barrier Can fill and seal tiny cracks Not attractive to insects Mixed and installed on-site by a professional Must be protected from prolonged UV exposure to sunlight Requires covering with a fire resistant material when used indoors	\$\$\$\$
XPS (extruded) Polystyrene Board	Confined spaces like basements, foundation slabs, crawl spaces or exterior walls. Must be tight fit to avoid gaps	May contain some recycled content and can be recycled itself. Uses HCFC as blowing agent Made from petrol chemicals Recyclable	Brominated flame retardants present a greater health concern than the nonbrominated flame retardants used in polyisocyanurate, spray polyurethane, and cellulose insulation.	4.7 - 5.0	Moisture resistant and suitable for below grade applications Must be protected from prolonged exposure to UV or solvents If joints are sealed can act as an air barrier With increasing thicknesses can act as a vapour barrier When installed on an interior surface must be covered with a fire resistant material mechanically fastened to the building structure	\$\$\$

Insulation Material	Common Application	Environmental Impact	IAQ impact	Typical R Value per inch	Other Considerations	Cost Effectiveness (\$-\$\$\$\$\$)
EPS (expanded) Polystyrene Board	Confined spaces like basements, crawl spaces or exterior walls. If below grade must be coated with foil or plastic. Must be tight fit to avoid gaps	May contain some recycled content and can be recycled itself. Made from petrol-chemicals	Brominated flame retardants present a greater health concern than the nonbrominated flame retardants used in polyisocyanurate, spray polyurethane, and cellulose insulation.	3.7 - 4.0	Moisture resistant and suitable for below grade applications Must be protected from prolonged exposure to UV or some solvents If joints are sealed can act as an air barrier With increasing thicknesses can act as a vapour barrier When installed on an interior surface must be covered with a firer resistant material mechanically fastened to the building structure	\$\$\$
Aerogel	Not yet ready for commercial use	This technology is still early in the production stage so comprehensive analysis of effects is not yet available. Some research is going into use of discarded corn husks for aerogel manufacture.	Aerogel dust can generate dry skin, eye irritation and respiratory interactions.	> 140	Light weight High compressive strength	\$\$\$\$\$
Polyurethane and Polyisocyanurate Board	Confined spaces like basements, foundation slabs, crawl spaces or exterior walls. Must be tight fit to avoid gaps Good for locations where a high R-value is required in a small thickness	Some brands use soy-based foams made from renewable vegetable oils and recycled plastics Can have some recycled content. Most brands no longer use formaldehyde or HCFC as the blowing agent Not recyclable Made from petrol chemicals	Boards are cured and the components are inert and do not effect IAQ	5.8 - 7.2	Usually come double faced with foil and sometimes bonded with an interior or exterior finishing material Foil face acts as a radiant heat barrier adding about R.2 to the insulation assembly Must be protected from prolonged exposure to UV or water If joints are sealed can act as an air barrier Can act as a vapour barrier Must be covered with a fire-resistant material	\$\$\$
Mineral Wool (Slag and Rock Wool)	Attics, wood-framed roofs, walls, floors and around chimneys	Made from natural basalt or volcanic rock and slag (a by-product, containing inert materials, produced during the blast furnace smelting process and other steel making operations, therefore post-industrial recycled waste up to 70%) When properly installed can save up to 1000 times the amount of energy used to produce it Product is recyclable Energy intensive to produce but less per R value than fibreglass	Scientific research shows material is safe to manufacture, install and use when following manufacturers instructions. Once installed no significant fibres are released. Can be CFC and HCFC free Mineral wool may contain up to 5 % phenol-formaldehyde by weight—more than most fibreglass insulations.	3.1	Non-combustible and can withstand temperatures up to 1000 °C Repels moisture Excellent acoustics barrier Ease of installation (placement and cutting for irregular spaces)	\$\$
Cellulose Fibre (blown or poured)	Typically between floor or ceiling joists (horizontally), can be used in wall studs (vertically) but installation may be restricted due to wall blocking, nails, cables, etc. Not to be used below grade Will require small holes to be blown into wall cavities	Up to 80% recycled paper, 20% fire retardant chemicals Requires up to 30 times less energy to make than fibreglass or mineral wool insulation	Inhalation of dust during installation VOC emissions from printing inks (although an increasing number of newsprint are using vegetable based inks.) Allergic reactions may occur from inks	3.6	Requires professional installation VOIDS unlikely with careful installer Absorbs moisture which may lead to fungal growth Combustible as fire retardant may not be consistent and may deteriorate over time Can settle up to 20% over time	\$\$



Insulation Material	Common Application	Environmental Impact	IAQ Impact	Typical R Value per inch	Other Considerations	Cost Effectiveness (\$-\$-\$-\$-\$)
Cotton Batt	Typically between floor or ceiling joists or wall studs	Cotton is a natural, renewable resource but the crop is water intensive, and can involve the use of pesticides or fertilizers which contribute to soil erosion. Some sources include scrap denim generated during denim manufacturing giving it a high recycled content. (70%+) Low energy consumption in manufacturing process Product can be recycled	No formaldehyde-based binders Safe to handle	3.6	Fire resistant with low flame spread rating Little or no settling Ease on installation (placement and cutting for irregular spaces) Good performance at low temperatures Will absorb moisture	\$\$
Sheep's Wool	Typically between floor or ceiling joists or wall studs	Wool is a natural renewable resource that is treated with a natural rubber and borax solution for forming into rolls. Borax is a naturally occurring non-volatile salt that is used for its pest-repellent, fire-retarding, and material preservation qualities. A natural latex rubber is used to allow borax to be applied to each fibre and increases the memory effect of the wool so that it will expand back to it's natural shape after being compressed during installation.	Borax is practically non toxic to birds, fish, aquatic invertebrates, and relatively non toxic to beneficial insects.	3.8	Good sound absorption. Natural buffering effect helps regulate indoor temperatures. Retains thickness reducing insulation efficiency overtime. Wool is also a natural fire retardant, safe to handle, renewable and recyclable.	\$\$
Wood Fibre Boards	Suitable for internal use as thermal and acoustic insulation on floors, walls and ceilings. They can also be used as external insulation with render protection and can receive lime and earth based clays band renders.	Wood fibre boards are rigid building boards made from sawmill off cuts that are pulped, soaked and formed into boards. The boards are then heated and compressed to their final thickness. Paraffin wax may be used as the binding agent.	Boards do not contain and glue or wood preservers. Non toxic in manufacture, use and waste disposal	3.8	99.5% waste material, off cuts from sawmill mainly. Very good breathability including hygroscopic moisture control to prevent moulds and improve indoor air quality. Uses about 1/10th the energy per tonne of product compared to plastic insulation boards. Wood fibre board insulation provides thermal mass to help regulate interior temperatures.	\$\$\$
Straw Bales	Used as infill in wall assemblies in post and beam construction or as a load bearing wall assembly. Straw bales are typically 18 or 24 inches wide, depending upon stack orientation.	Any type of straw can be used, wheats, oats, barley, etc. The bales are made from the agriculture waste of the harvest, which is annually renewable and in many parts of the world is typically burned in the field.	Straw bales are a non-toxic product that allows a gradual transfer of air through the wall, bringing fresh air into your living environment, especially when combined with a natural plaster. Most straw bale houses do not incorporate vapour, air or moisture barriers as they want the natural breathability of the wall which further reduces the number of man made chemicals impacting the indoor air quality.	2.7	Excellent fire resistance qualities, a plastered straw bale wall will easily pass a two-hour fire test. Straw bales houses have stood the test of time, some being older than 100 years. Excellent sound absorption and ease of building can reduce construction costs. Requires large overhangs for moisture protection in rainy climates	\$\$



## 5.2 Selecting Insulation Materials

Insulation can serve as more than just an energy barrier, providing fire resistance, humidity control, and noise reduction among other things. Many fibre-based materials, such as cellulose or wood fibre, are sensitive to water exposure – a common concern in Vancouver’s climate. On the other hand, these materials can also act to modify humidity levels, which is particularly relevant for structures which are meant to breathe, such as those which use straw bales.

- Select materials by balancing their relative strengths and weaknesses against environmental impact considerations. Table 2 provides a comparison of common insulation materials and their applications.

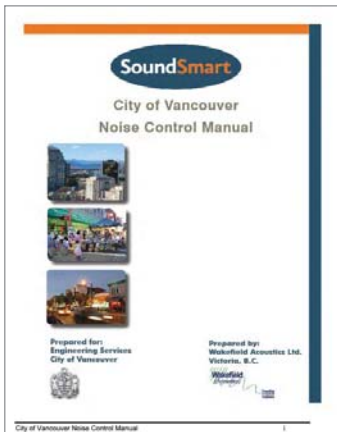

□ **The City of Vancouver Sound Smart Manual can be found at [www.city.vancouver.bc.ca/engsvcs/projects/soundsmart/pdfs/NCM1.pdf](http://www.city.vancouver.bc.ca/engsvcs/projects/soundsmart/pdfs/NCM1.pdf). This document contains detailed information on sound control and the use of building materials and orientation to mitigate noise pollution.**

### Fire Resistance

The combustibility of insulation materials is also an important consideration, although deaths in fire situations are more commonly caused by the inhalation of smoke generated by combustion of the room contents rather than the building envelope materials. Products like rock wool or even cellulose and wood fibre perform better in fire situations than polyurethane or polystyrene based foams or fiberglass.

Another potential problem is the chimney effect caused by shrinking of insulation materials within the wall cavities. Gaps of 19mm or greater can lead to a convection loop, allowing flames to spread more quickly from storey to storey.

### Noise Reduction

Noise reduction can be a valuable indirect benefit of thermal insulation. There are two characteristics materials need to display in order to have a positive influence on noise reduction: high mass and flexibility. Polystyrene or polyurethane, for example, display neither and therefore have nearly no influence on noise. Rock wool, fiberglass and cellulose fibres are soft and have a significant mass, so they can make a contribution to noise reduction. The densest insulating material is wood wool, which is a very efficient sound deadener.

### Specific Heat Capacity

This term is used to compare the heat storage capacity per unit weight of different materials. Unlike thermal mass, heat capacity is not linearly related to weight; instead it quantifies the heat storage capacity of a building element or structure, rather than its ability to absorb and transmit that heat.

The thermal mass of a material or assembly is a combination of three properties:

- Specific heat
- Density
- Thermal conductivity

### 5.3 Airtightness

It is imperative for a structure to have an airtight layer in order for insulation to be effective. There are several strategies for achieving a super tight building envelope.

#### Air Barriers

Up to 25 percent of the energy loss in a building is attributable to air leakage. This can be addressed quite easily in new construction with careful attention to draught sealing, as well as carefully designed air locks (such as double doors). Poor airtightness can also contribute to mould problems if warm humid air is allowed to seep into the structure. Renovations are more complicated, though an airtight layer has to be added to the existing structure.

#### Moisture Barrier

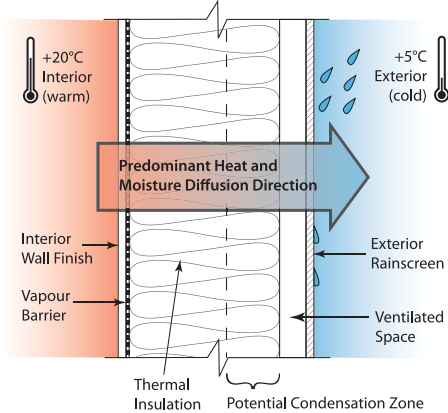

An air barrier system should be continuous around all components of the building, with special attention given to walls, roof and the lowest floor. There must be proper continuity at intersections, such as the connection between floors, the joints between walls and

windows or doors, and the joint between walls and the roof.

External house wrap, polyethylene and airtight drywall are probably the most common techniques for creating an air barrier. Correct sealants and caulking can help to stop leaks and must be properly installed to ensure durability over time.

#### Vapour barriers

Vapour pressure is generally higher inside a building due to the moisture generated by the occupants and their activities. This will create an external flow of vapour towards the outside, where the pressure is lower. If the vapour is allowed to move through the assembly it can condense on the surface leading to dampness and ultimately to mould or rot.

A vapour barrier reduces the movement of the vapour through the building assembly so that condensation does not occur. There are several types of vapour retardants including polyethylene, foil or latex paint. Unlike an air barrier the continuity of the vapour barrier is not as crucial as it can still perform well even if gaps are present.

### 5.4 Thermal Bridges

A thermal bridge occurs where construction materials create a bridge between internal and external environments allowing a heat transfer to occur. Metal is highly conductive and therefore susceptible to thermal bridges but any material can contribute to this effect to some



□ Up to 25 percent of the energy loss in a building is attributable to air leakage.

□ Energy modeling software

**EE4:** Software to assess the energy performance of your design and verify design compliance against the Model National Energy Code for Buildings (MNECB). Available from Natural Resources Canada at [http://www.sbc.nrcan.gc.ca/software\\_and\\_tools/ee4\\_soft\\_e.asp](http://www.sbc.nrcan.gc.ca/software_and_tools/ee4_soft_e.asp).

**Hot2000:** A low rise residential energy analysis and design software available from Natural Resources Canada at [http://www.sbc.nrcan.gc.ca/software\\_and\\_tools/hot2000\\_e.asp](http://www.sbc.nrcan.gc.ca/software_and_tools/hot2000_e.asp).

**RETScreen:** Evaluates the energy production and savings, costs, emission reductions, financial viability and risk for various Renewable Energy and Energy Efficient Technologies (RETs). Available from Natural Resources Canada at <http://www.retscreen.net/ang/home.php>.

degree. Wherever possible, thermal bridges need to be avoided through the use of a thermal break.

Thermal breaks are literally breaks inserted into the component (for instance in the window frame), which separate the exterior and interior materials.

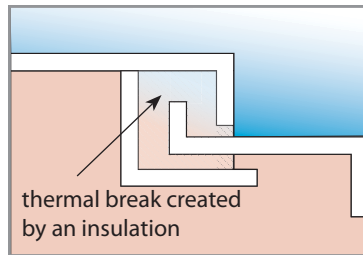

## 5.5 Assemblies

Cavity walls

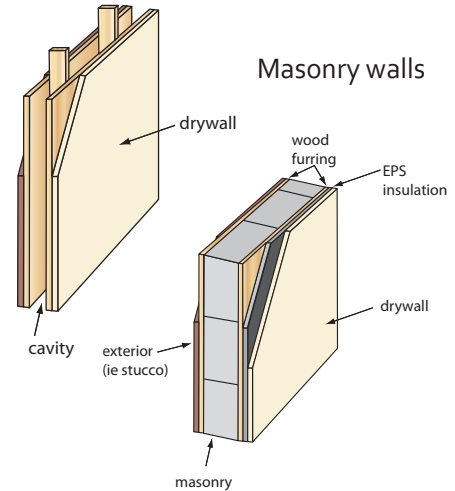

### Insulation:

Cost: \$\$\$\$ - \$\$\$\$

Insulation is one of the most critical elements in reducing energy consumption requirements by avoiding unnecessary loss of thermal energy. The choice of material can also have non-energy related positive impacts.

### Synergies/Barriers:

- When making decisions regarding insulation one should consider the whole building as a system and account for airtightness and vapour protection.
- Energy modeling, for instance using HOT2000 software can help to determine when increasing insulation in a certain part of the building will improve performance and when it can no longer make a difference.
- It is important to remember that the main source of heat loss is through the windows, so it is essential to install high performance frames and to reduce thermal bridges in these areas.

### Impact on Energy Efficiency:

Insulation lowers the need for heating and cooling, reducing overall energy consumption.

## 6. Windows (Glazing)

One of the most efficient ways to harness the power of the sun is through the use of suitable window technologies. Conventional residential buildings lose upwards of 50 percent of their heat through windows. At the same time, passive solar gain through windows is generally limited to just a few percent. In order to design windows that contribute to passive heating in the cooler winter months without an associated overheating risk in the summer, it is critical to balance location, size and thermal quality.



photo:melis+melis+wimmers

When making window decisions, consider the following:

*How does window design address daylighting, views, ventilation?*

*How much heat loss will be attributable to the windows?*

*What is the payback for investing in high performance systems?*

*Are there other design considerations? (Overhangs, landscaping etc.)*

### 6.1 Thermal Quality and Style of Window

The overall quality of a window is key to its performance and can be determined by the thermal quality of the glass and the frame. Further considerations are the solar heat gain coefficient of the glass and of the spacer material.

The style of window will also have an effect on its performance. Slider windows may be poorer air barriers as the sealing system is harder to design. Fixed windows are permanently sealed but do not offer the benefits of ventilation, while hinged windows use compression seals that, while more sturdy than slider windows may still wear out. Seals may wear out and not be replaced.

### Heat gain / heat loss

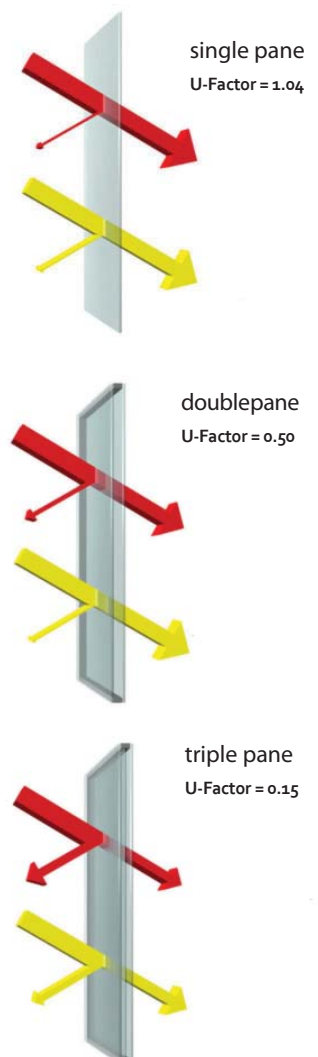

**What is a U Value?**

U-value is measured by  $U = 1/R$

U-values for windows can refer to the centre of glass or edge of window 'whole frame' measurements.

The value will change with the size of the window because the ratio of window to frame will increase as the window gets bigger.

Most manufacturers provide the U value of the glass and the frame separately – proper analysis must assess the U value of the entire system.

**Table 3**  
**Thermal Quality of Glass**

<p><b>Low-e windows:</b> Double pane glass with a U-value ranging from 1.1-1.5 W/m<sup>2</sup>K and a solar heat gain coefficient of approximately 60%.</p>	<p>This type of window is more or less energy neutral when placed on the southerly side of a building, meaning solar gain is approximately the same as solar loss. If placed in any other location, this type of glass loses more energy than it gains. Therefore, it is recommended to avoid low-e windows when working with passive design especially in Vancouver which gets less than 2.5 hours of sun per day during the winter.</p>
<p><b>Super high performance windows:</b> Triple pane glass with a U-value ranging from 0.5-0.7 W/m<sup>2</sup>K and a solar heat gain coefficient of 50-60%.</p>	<p>When used in cooperation with a super-insulated frame, these windows can facilitate solar heat gain. During cold or overcast days, or overnight, a window using this type of glass will lose less energy than it can capture during sunnier periods. Increasing the proportion of glass of this quality on the southerly side will encourage more passive solar gain.</p>

A precondition for the glass to deliver the performance as per table 4, is a super-insulated frame. Installing high performance triple pane glass into a common frame would be inefficient. Even using this combination, the frame is the weakest link delivering nearly no solar gain while also creating thermal

bridges. In other words, windows are always a source of energy loss.

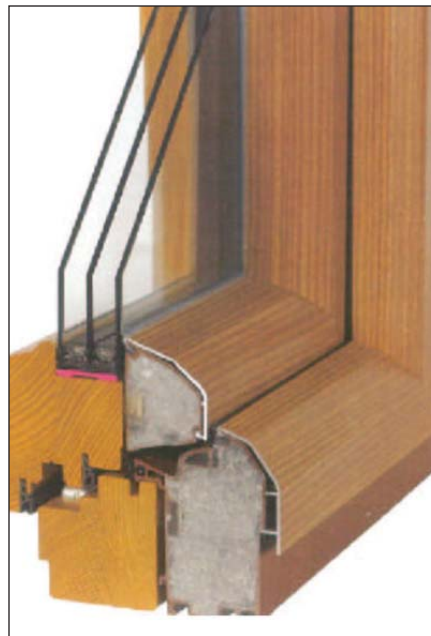



**Table 4 – Thermal Quality of Frame**

<b>Common wood or vinyl frame</b>	Generally has a U-value between 2.0-2.5 W/m <sup>2</sup> K. These are the most commonly used.
<b>Metal or aluminium frames</b>	Though strong, these materials have high heat conductivity – aluminium can decrease the insulating value of a window by 20 to 30 percent. These frames, combined with triple pane windows, would reach a maximum U-value of 1.6-2.0 W/m <sup>2</sup> K even if thermal breaks were inserted in the design. See Chapter 5 for discussion on thermal breaks.
<b>Timber frames</b>	Good insulator but requires more maintenance than aluminium. Wood used in their manufacture should be sourced from a sustainable forest (see FSC certification).
<b>Composite frames</b>	Aluminium outer sections with either a timber or uPVC inner section.
<b>Super insulated frames</b>	May consist of wood or a wood/metal composite window frame which is hollowed out and filled in with foam or some other form of insulation. These types of frame may reach U-values of under 0.8 W/m <sup>2</sup> K – a good fit for 0.7 or better windows.

- Use a super high performance window and frame to mitigate the amount of energy lost through windows.
- Select window styles with durable seals.
- Keep in mind that this strategy is important, as nearly half of the energy loss of a home is associated with windows.



□ Super high performance windows used in cooperation with a super-insulated frame can facilitate solar heat gain



## Passive window shading

Overhang

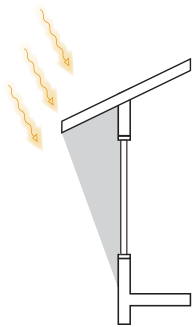

Louvres

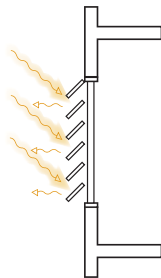

Sunshades

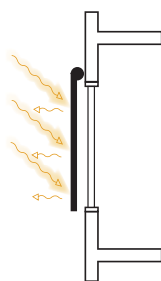

## 6.2 Location and Size of Windows

For a complete discussion of appropriate locations for windows, see the discussion in Section 3.2.

It is also important to remember that, in addition to having the lowest insulation value as a component of the building envelope, windows are also a source for thermal bridges. Therefore, an appropriate number of windows will mitigate unnecessary heat loss or gain. As a general rule of thumb, windows should not exceed  $2/3$  of the envelope.

In fact, due to the nature of thermal bridges, the number of individual windows should also be kept to a minimum – one slightly larger window is more efficient than two windows even if they equal the same area of window.

- Do not overglaze.
- Minimize the number of windows.

## 6.3 Shading

Appropriate use of shading can prevent too much heat from entering a building by shading the glass from direct sun light. This is particularly important for the south elevation during the warm summer months. Shading strategies can include using overhangs, eaves, louvres and sunshades to regulate solar access.

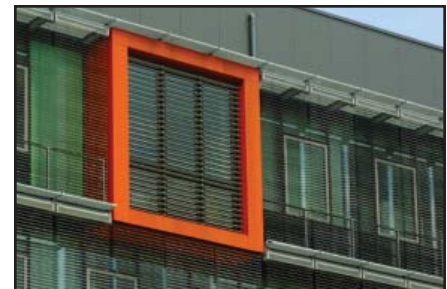

Louvres are used for shading on this building in Heidelberg, Germany

- Properly size and position overhangs to reduce solar gain during the times of the year it is not required

### Passive window shading

Curtains can be used to improve the performance of existing windows but are neither efficient nor effective as the solar heat gain is already inside the building envelope. Heavy curtains may reduce heat loss, but air movement will still encourage the warm air to escape. Blinds can work to reduce glare, but they are also not effective at blocking solar heat gain.

Exterior shading, such as automated blinds, are not truly passive as they consume energy, materials and resources in their manufacture. They also include working parts which are susceptible to failure.

Louvres offer non-mechanical exterior shading

## Windows:

Cost: \$\$\$\$

Window strategies are one of the most effective methods to make use of solar gain and limit energy loss. Proper attention to windows and shading can ensure maximizing winter sun, while also preventing summer overheating.

### Synergies/Barriers:

- It is important to balance solar considerations of windows with natural daylighting and view considerations.
- High performance windows can be expensive. Aim for the lowest U-value that is affordable and avoid overglazing.

### Impact on Energy Efficiency:

Appropriate use of this strategy can greatly increase the energy efficiency of a building.

# 7. Lighting

Daylighting and access to natural sunlight are essential for living spaces, as this quality of light promotes occupant comfort. Good daylighting eliminates the need for artificial lighting, reducing energy consumption for this purpose.

## 7.1 Interior Layout and Windows

When making decisions about lighting it is important to consider that appropriate building layout and orientation can reduce the need for artificial lighting and thus improve occupant comfort. Building layout should respond to the path of the sun, providing a sufficient supply of natural daylight through windows. South facing windows provide lots of daylight, as well as solar gains, while windows facing the northern elevation can deliver diffused lighting with minimal solar gain.

Good passive design should situate windows in multiple directions in order to balance interior lighting requirements. With the appropriate strategy, the amount and quality of light can be varied according to the lighting requirements of each space; direct light for kitchens, offices and workshops, and reflected or diffused light for living rooms or bedrooms.

- Use multiple window orientations for balanced lighting levels
- Choose lighting schemes based on room function

For further discussion of layout and windows, see Sections 4 and 6

When designing a passive lighting strategy, here are some questions to ponder:

*What is the primary function of this room and what type of light does it require?*

*When will the room be occupied (morning, afternoon, evening)?*

*What is the most appropriate style and placement for windows considering the path of the sun?*

## 7.2 Skylights vs. Solar Tubes

Although skylights can bring in lots of natural daylight, they are also a source of heat loss in the winter and heat gain in the summer.

Solar tubes, on the other hand, are simpler to install and provide daylight without the associated heat gain and a minimal amount of heat loss. Solar tubes are lined with reflective material to reflect and diffuse light to isolated areas.

- Use reflection techniques and solar tubes to funnel daylight into the house

## 7.3 Clerestory Windows

A clerestory wall is a high wall with a row of overhead windows that

## Types of Daylighting

Light Shelf

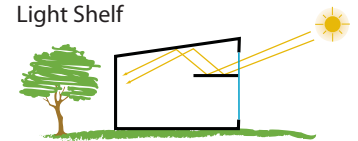

Light Duct

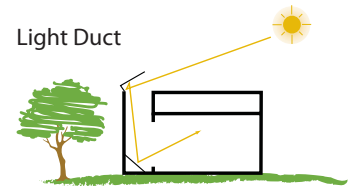

Reflective Blinds

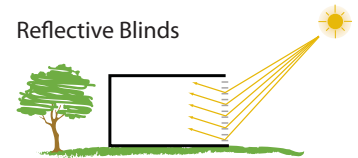

Solar Tube

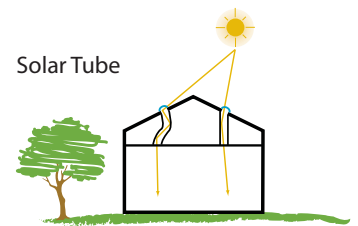

Sky Light



Roof Monitors

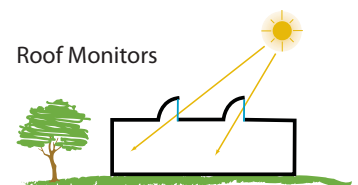

## Types of Daylighting continued...

Atrium

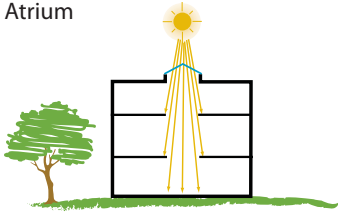

Clerestory

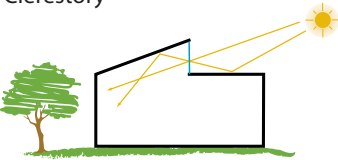

External Reflectors

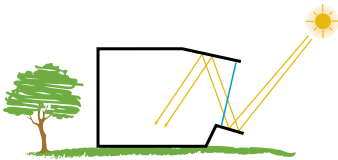

can allow in light. When clerestory windows are opened they can also act to cool the room by creating convection currents which circulate the air.

- Position clerestory windows to face south, with eaves to block the hot summer sun



### Heat gain from artificial lighting fixtures

Less than 10% of the energy use of a standard incandescent bulb (e.g. 40W, 60W, 100W tungsten filament bulbs) is converted to visible light, with the rest ending up as heat energy. Using more energy efficient light bulbs will ensure energy is efficiently directed to deliver its assigned purpose, in this case artificial lighting.

Compact Fluorescent Lights (CFLs) are the most significant development in home lighting, lasting up to 13 times as long as incandescent bulbs and using about ¼ the amount of electricity. New and improved colour renditions give a warmer light than older CFL technology.

Tungsten-halogen lamps are a newer generation of incandescent lights that provide a bright, white light close to daylight quality. These are powerful high-voltage lamps best used for general illumination.

More energy-efficient, low-voltage halogen lights are ideal for accent lighting. These lamps can last as long as 2000 hours and save up to 60% of the electricity used with incandescent lights.

Automation techniques and smart technology also help to mitigate high energy use. Dimmer switches and motion detectors can automatically adjust to conditions based on a predetermined schedule.

- Reduce as much as possible the reliance on artificial light
- Increase illumination effectiveness by using light coloured sources
- Use low wattage bulbs close to where they are needed
- Use energy efficient bulbs instead of regular incandescents
- Eliminate the unnecessary over-use of electricity with the use of dimmers, timers, motion sensors and cupboard contact switches





#### 7.4 Paint as a Passive Lighting Strategy

The albedo of an object refers to its capacity to reflect light. Light coloured paints can make spaces look and feel brighter while also mitigating the heat island effect through reduced heat absorption.

In winter, when solar radiation is not as intense and solar gains are sought after, high albedo surfaces adjacent to the house can reflect solar radiation into the house, to be

absorbed by the internal thermal mass. This strategy also provides daylight into the interior, as well as increasing nighttime lighting levels.

- Select appropriate surfaces to paint with light coloured paint or other high albedo material
- Decide where light is required and balance with heat considerations
- White painted windowsills can increase the amount of light into a room by reflecting outside light

□ Light coloured paints can make spaces look and feel brighter while also mitigating heat island effect.

#### Heat Island Effect

A heat island is an area, such as a city or industrial site, having consistently higher temperatures than surrounding areas because of a greater retention of heat by buildings, concrete, and asphalt. Causes of the “heat island effect” include dark surfaces that absorb more heat from the sun and lack of vegetation which could provide shade or cool the air.

**Lighting:**

**Cost:** \$\$\$\$ - \$\$\$\$\$

Passive lighting implies maximizing the use of natural daylighting in order to reduce the reliance on artificial lighting fixtures, which can be costly and inefficient.

**Synergies/Barriers:**

- Lighting strategies need to be balanced against solar heat gains.
- Clerestories and solar tubes can be appropriate where privacy is necessary.
- When choosing window styles for lighting remember to keep in mind other passive design best practices such as quality of windows and ventilation.
- High gloss paint leads to acute brightness – to achieve passive lighting use matte paint to deliver a softer brightness.
- Shade reflective surfaces with overhangs, trees or vegetation to mitigate unwanted heat gain in the summer.

**Impact on Energy Efficiency:**

Decreasing dependence on artificial lighting can help to curb energy consumption but natural light also contributes to higher occupant comfort. This strategy can be achieved with minimal extra associated costs.

# 8. Ventilation

When there is a difference between outdoor and indoor temperature, ventilation can be accomplished by natural means. Strategically placed windows make use of prevailing winds to allow ventilation, bringing in fresh air while removing warm or stale air. Ventilation also has an impact on heating and cooling.

When considering ventilation strategies, it is helpful to consider the following questions:

*How will the window contribute to occupant comfort?*

*Where should windows be located to achieve the desired impact?*

## 8.1 Window Placement

The height and opening direction will affect the degree to which a window can take advantage of prevailing winds. Well thought out height and placement will direct air to where it is needed, while choosing windows that either open inward, outward or slide will affect the amount of air that can be captured.

Though ventilation has an impact on heating and cooling it also has stand alone merits to improve occupant comfort through appropriate access to fresh air.

- Know the patterns of prevailing winds
- Identify wind flow patterns around the building
- Account for site elements such as

vegetation, hills or neighbouring buildings which will impact breezes

- Orient fenestration and choose a style that catches and directs the wind as required

## 8.2 Stack Effect and Cross Ventilation

The following strategies can effectively encourage passive ventilation in a house.

Stack effect is achieved by placing some windows at lower levels (in the basement or at floor level), while others are placed at higher levels (at ceiling height or on the top floor). The lighter, warm air is displaced by the heavier, cool air entering the building, leading to natural ventilation. This warm/light interaction acts as a motor that keeps the air flowing, leading to what is called the 'stack' or 'chimney' effect. The greater the temperature difference, the stronger the air flow generated.

This kind of natural ventilation is appropriate for summer months, as it may also cool the interior space, reducing the need for electric fans or pumps traditionally used for cooling. This in turn can lead to lower energy consumption.

### Stack effect

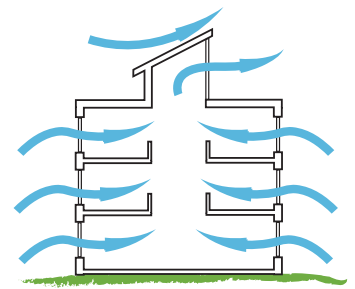

### Cross ventilation

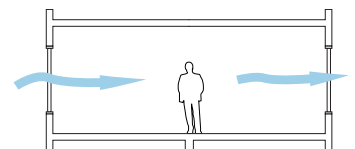

Cross ventilation occurs between windows on different exterior wall elevations. Patio and screen doors are also effective for cross ventilation. In areas that experience unwanted solar gain, operable clerestory windows or ceiling/roof space vents can aid with ventilation and cooling (see Section 8.3).

- Place windows where it is possible to achieve either stack effect or cross ventilation where required
- Use appropriate window style to achieve desired effect

### 8.3 Window Style

The style and operability of a window can determine maximum levels of ventilation achievable. Louvres or hinged/pivoting units that open to at least 90 degrees can offer the greatest potential for ventilation. Awning, hopper or casement windows, opened by short winders, provide the least potential.

- Maximize window opening and use hinged windows which can redirect breezes

### 8.4 Heat Recovery Ventilators

Heat recovery ventilators, or HRVs, are not strictly passive technology, but are recommended as part of a comprehensive passive design strategy. Ventilation which makes use of an HRV is more efficient, as the system reclaims waste energy from exhaust airflows. Incoming fresh air is then heated using this energy, recapturing 60 to 80 percent of the heat that would have been lost.

Passive design essentially encourages a very tight building envelope, while an HRV ensures a continuous supply of fresh air to this airtight interior. Filtration of the air through an HRV also stops dirt from entering the building, and can help to prevent development of mould.

### Heat recovery ventilator

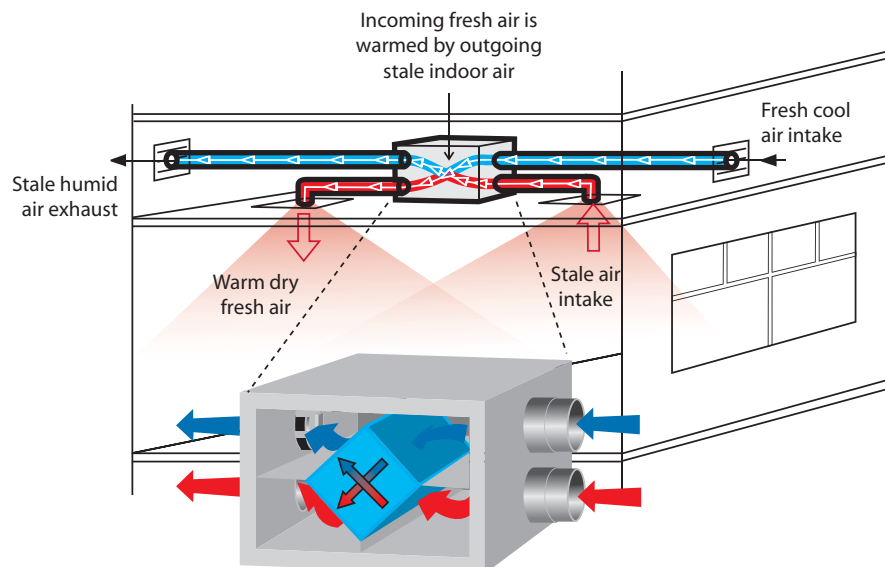

- Aim for a heat recovery rate greater than 75%, an leakage rate of less than 3%, and electricity efficiency of the unit greater than 0.4 Wh/m<sup>3</sup> (0.04 Btu/ft<sup>3</sup>)
- Provide ventilation controls that have user-operated settings for “low”, “normal” and “high”, and consider additional controls in kitchen and baths/toilets

**Ventilation:**

**Cost: \$\$\$\$\$ - \$\$\$\$\$**

Natural ventilation eliminates the need for big mechanical systems and can provide occupant control over thermal comfort.

**Synergies/Barriers:**

- Keep in mind that site conditions affect the ability to capture wind: allow for landscape, building shape and prevailing winds.
- Security and wind driven rain should also be considered when deciding window or door placement.
- HRVs require additional ducting to bring the exhaust air back to the HRV unit.
- Exhaust from nearby cars and other external pollutants should be accounted for.
- Unwanted heat loss can be reduced by preheating incoming air prior to distribution (using an HRV or other system).

**Impact on Energy Efficiency:**

Using passive strategies for ventilation can leverage natural climatic conditions for little or no extra cost.



# 9. Thermal Mass

Thermal mass is a measure of a material’s capacity to absorb heating or cooling energy. Materials such as concrete or bricks are highly dense and require a lot of energy to be heated or cooled. On the other hand, materials such as timber are less dense and do not need to absorb much energy for smaller changes in temperature. The more energy it takes to affect a temperature change of the material, the higher the thermal mass. The time it takes for the material to store and then release the heat energy is referred to as the *thermal lag*.

The thickness of a material impacts its energy storage capacity. For example, steel studs have a greater thermal mass than wood studs. The density of insulation materials differs and further affects thermal resistance values.

**Table 5**  
Common density values

Material	density
Foams	15-40 kg/m <sup>3</sup>
Wood Fibre	160 kg/m <sup>3</sup>
Fibreglass	50-60 kg/m <sup>3</sup>

The simple application of thermal mass can work to passively heat or cool a building, as internal changes in temperature can be moderated to remove extremes of heat or cold. The reverse is also true; inappropriately located thermal mass can cause external temperatures to disproportionately affect internal thermal comfort.

Before increasing thermal mass to an area of a building, consider:

*Will this location be best to exploit solar gain?*

*Can this location be shaded to avoid gain when it is not required?*

## 9.1 How to Use Thermal Mass

How can this be applied to low rise wood framed construction ?

When using thermal mass it is critical to understand that it behaves differently than insulating material. Thermal mass is the ability of a material to store heat energy and then release it gradually. Insulating materials, on the other hand, prevent heat from passing through them. In fact, many high thermal mass materials display poor insulation characteristics.

The embodied energy in some thermal mass materials may also be taken into consideration. Some materials, such as concrete,

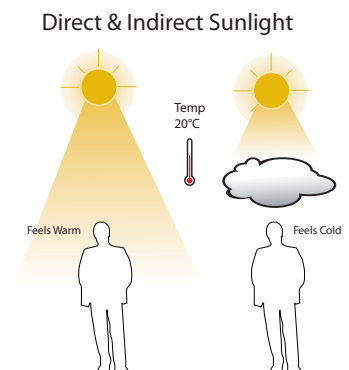

## Thermal Mass

### Structure with thermal massing:

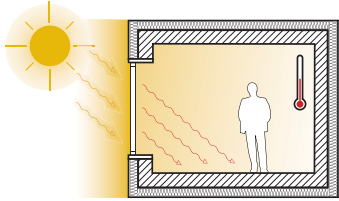

Sun enters room and heat is absorbed into flooring keeping the room temperature comfortable

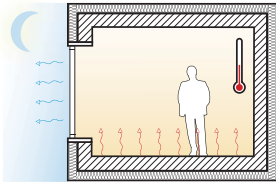

Heat that was absorbed is released during the cool evening to add warmth to the room

### Structure with no thermal massing:

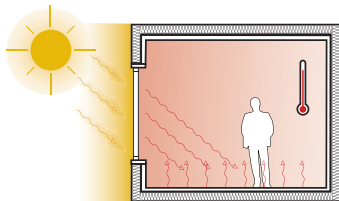

In a room without thermal massing, heat from the sun is reflected into the room causing uncomfortable warmer temperatures

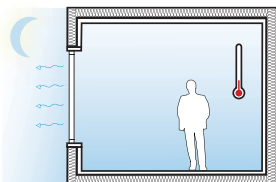

In the cool evenings, a room without thermal massing will be uncomfortably cold

require a lot of energy to manufacture and are inappropriate in relation to the actual energy savings they might deliver.

Mass situated on the south side of a building is most efficient for heating in Vancouver. The mass can absorb heat from the sun and then release this energy during the night. To avoid overheating, areas with high thermal mass should be shaded from this sun in the summer, or situated/landscaped to take advantage of cooling winds.

Thermal mass should generally be located on the ground floor, on the inside of a building, exposed to the indoor environment. Exposed

concrete floors or concrete block partition walls are very effective at absorbing thermal conditions (heat or cold).

- Use the south side for thermal mass, but apply appropriate shading for summer months
- Apply thermal mass on the ground level

## 9.2 Slab on grade construction

Slab on grade (SOG) is a very common method to create thermal mass. Generally about 4" thick, SOG should be insulated from the ground below to avoid losing heat in the winter.

## Radiant Heating

### Radiant heat flooring vs. forced air heating

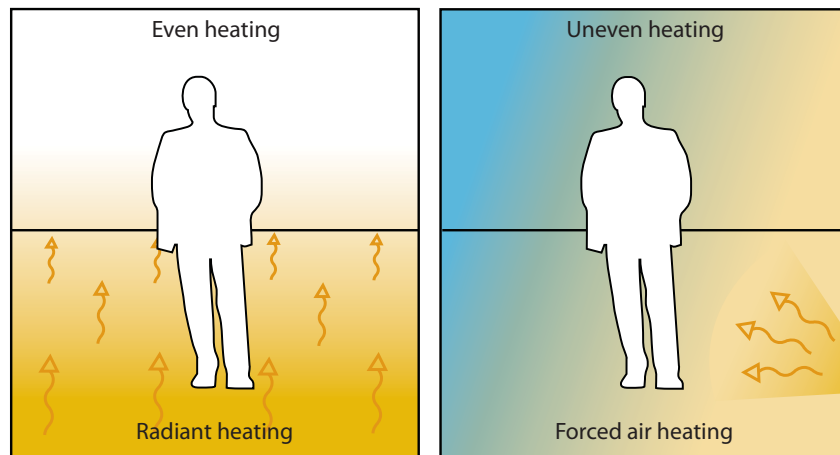

Radiant energy can be beneficial – this type of energy is emitted from a heat source and is different from tradition convection heating. This type of heating can penetrate all objects in its path and rather than heating the air, directly heats all objects in its path, including people.

This type of heating system can achieve the same level of thermal comfort using less energy, as heat is not lost to the air. Radiant systems include in-floor, ceiling panels or wall heating systems.

### Phase Changing Materials

There is growing interest in the use of phase changing materials in construction. These are materials that can either emit or store heat energy as they change from a solid to a liquid or vice versa at certain temperatures. Therefore, these materials can be used, like thermal mass, to manage indoor thermal comfort.

#### Thermal Mass:

Cost: \$\$\$\$ - \$\$\$\$\$

Thermal mass can be effectively used to absorb solar heat in winter and radiate it back to the interior at night.

#### Synergies/Barriers:

- Vancouver has minimal winter sun, so this strategy has limitations to significantly offset winter heating demands though it may be sufficient for shoulder season demands (spring and autumn).
- Naturally occurring thermal mass areas can be used to reduce cooling demands more easily – keep high thermal mass elements shaded or away from solar gains.

#### Impact on Energy Efficiency:

Allows the house to heat and cool itself based on heat release from materials, lowering the need for additional heating.

## 10. Density

In addition to building design, there are other elements that can impact the passive potential of a site. Density, measured in Vancouver as the ratio of building floor space to the site area, impacts energy consumption as well as the capacity of a building to be passively heated or cooled.



Density is regulated in most municipalities, including the City of Vancouver, by zoning by-laws based on development and planning policies. Though there is a process for rezoning applications, density cannot always be increased in every instance. Municipalities often have areas earmarked for greater density based on community plans, and the City of Vancouver has also introduced its EcoDensity policy, which aims to encourage density around transportation and amenity-rich nodes.

In general, large, single-family dwellings have a higher proportion of exterior wall surface and constitute lower density areas. These buildings require more energy for heating or cooling purposes, while 'denser', multi-unit buildings, townhouses or duplexes can take advantage of economies of scale and share or transfer heat between walls or floors thereby reducing overall energy demand. In fact, low-density developments comprising mainly single-family houses use nearly twice as much energy per square foot as multi-unit buildings in Canada.

□ **Multi-unit buildings take advantage of economies of scale and share or transfer heat between floors and walls thereby reducing overall energy demand.**

According to a 2006 study, low-density suburban development is more energy and GHG intensive by a factor of 2.0–2.5 than high-density urban core development.

The analysis is based on a per capita calculation. When this functional unit is changed to per square meter of living space, the factor decreases to 1.0–1.5. This suggests that the choice of functional unit is highly relevant to a full understanding of the effects of density, although the results do still indicate in many cases a marginally higher energy usage in low density development.

From:  
'Comparing High and Low Residential Density', Jonathan Norman, Heather L. MacLean, and Christopher A. Kennedy, *Journal of Urban Planning and Development*, Vol. 132, No. 1, March 2006, pp. 10-21

□ Single-family dwellings take up half of the land area in Vancouver. In fact, only 11 percent of the city's land area is currently used for multiple-unit dwellings, according to the City of Vancouver's EcoDensity website.



### Density

Density can mitigate pressure on municipal infrastructure including waste, sewer and energy infrastructure. Appropriate use of density can also create efficiencies in the use of this infrastructure, and lead to shared benefits from energy usage and common amenities.

#### Synergies/Barriers:

- Density is largely determined by wider municipal planning policy so there is little scope for variations on a building by building basis.



# 11. Benefits of Passive Design



The strategies in this toolkit offer suggestions for harnessing the power of the sun and decreasing the energy consumption requirements of a typical home. As in other parts of the world, it seems reasonable to be able achieve a reduction to just 15kWh/m<sup>2</sup>/year (heat/cool) if all strategies are used in combination. It is important to keep in mind that reducing consumption is the first step to designing energy efficient homes and approaching carbon neutrality (ie this should come before any discussion of on-site energy generation).

To get an idea of the possible impacts/benefits of passive design on energy consumption, consider the case study presented in the tables on the following page.

In short, a typical Vancouver single family home is 200 m<sup>2</sup>, with a 2x6 fully insulated stud wall and conventional windows with low-e windows. The average annual energy loss associated with a building of these specifications would equal roughly 16,000 kWh, or about 80 kWh / m<sup>2</sup> / year. The passive solar energy harnessed by this home would be relatively small, at about 1,200 kWh per year, or roughly 7.5% of the amount of energy lost. Annual heating demand would average 64 kWh / m<sup>2</sup> / year.



photo:melis+melis+wimmers

## Case Study

Table 6 shows the usual approach and the resulting energy consumption. The energy loss of 18,000 kWh is relatively high and the passive solar impact is with less than 7 percent extremely low.

The second example (Table 7) is based on a typical Vancouver single family home with a small rental unit in the basement. With a total floor area of 208 m<sup>2</sup>, the house was retrofitted during the last year.

**Table 6:**  
**Typical Vancouver Single Family Home**



Size of Building	208 m <sup>2</sup>
Wall assembly	basement 2x6 fully insulated stud wall. Concrete with 2" XPS
Windows	30 m <sup>2</sup> Conventional, low-e U Value=1.6 thereof 7.4 m <sup>2</sup> on south side
Energy loss	18,000 kWh ≈ 80 kWh / m <sup>2</sup> / year
Solar gain	1,200 kWh ≈ 6.6% of energy loss
Heating demand	69 kWh / m <sup>2</sup> / year

This home is lined up against the typical Vancouver house (Table 6) with no recent upgrades. The resulting energy consumption and loss of 18,000 kWh is relatively high, but not an unreasonable assumption. The passive solar harnessed by this building is less than 7 percent of consumption, which is extremely low but again, not an unreasonable assumption with recent construction and design practices.

The main differences between the original house and the improved example in the case study are:

- improved insulation thicknesses
- improved air tightness
- optimizing of heat bridges
- improved thermal quality of windows
- installation of heat recovery unit

With these improvements, total energy loss was reduced significantly despite the fact that it was possible to improve passive solar gain to only 10 percent of energy requirements, which is still very low performance.

**Table 7:**  
**Better Vancouver Single Family Home**



Size of Building	208 m <sup>2</sup>
Wall assembly	basement 2x6 fully insulated stud wall plus 2" exterior insulation. Concrete with 3" XPS
Windows	Ventilation with heat recovery 37 m <sup>2</sup> Triple pane and insulated frame U Value = 0.78 thereof 7.4 m <sup>2</sup> on south side 82% (air tightness @ 50Pa 0.77/h)
Energy loss	9,500 kWh ≈ 46 kWh / m <sup>2</sup> / year
Solar gain	1,000 kWh ≈ 10.5% of energy loss
Heating demand	29 kWh / m <sup>2</sup> / year

For comparison, the third example (Table 8) offers an estimate of the possible performance associated with a truly passively designed home. In this third instance, improvements would include:

- further increases to insulation
- window placement based on building orientation

Allowing the windows to be distributed according to solar gain potential increases the solar energy the building harnesses to 35 percent. By placing a larger proportion of windows on the southern elevation and less on the northern elevation, the passive design features of this building improve its performance by nearly fivefold over the first example.

**Table 8:**  
**Passive Vancouver Single Family Home**



Size of Building	208 m <sup>2</sup>
Wall assembly	basement 2x6 fully insulated stud wall plus 3.5" exterior insulation Concrete with 6" XPS
Windows	Ventilation with heat recovery 45 m <sup>2</sup> Triple pane and insulated frame U Value = 0.78 thereof 21.5 m <sup>2</sup> on south side 82% (air tightness @ 50Pa 0.6/h)
Energy loss	8,400 kWh ≈ 40 kWh / m <sup>2</sup> / year
Solar gain	3,200 kWh ≈ 38% of energy loss
Heating demand	15 kWh / m <sup>2</sup> / year (PassivHaus standard)

# Bibliography

Diamond, R. 1995. "Energy savings rise high in multifamily buildings." Home Energy Magazine

McMullen, R. 2002. Environmental science in building, Palgrave, New York.

Norman, J., H. MacLean & C. Kennedy. 2006. Comparing High and Low Residential Density: Life-Cycle Analysis of Energy Use and Greenhouse Gas Emissions, Journal Of Urban Planning And Development / March 2006

OEE NRCan 2006. Energy Use Data Handbook 1990 and 1998 to 2004

Light House Sustainable Building Centre. Cost assessment of a bundle of green measures for new Part 9 buildings in the City of Vancouver. 2008: City of Vancouver

Schaeffer, J. 2008. Solar Living Source Book, New Society Publishers, BC.

Pearson, D. 1998. The New Natural House Book. Fireside, NY.

Roaf, S. 2007. Ecohouse. Architectural Press, Oxford UK

Kachadorian, J. 1997. The Passive Solar House, Chelsea Green Publishing Company, Vermont, USA.

Tap the sun, Passive Solar Techniques and Home Designs, Natural Resources Canada and CMHC.



# i. City of Vancouver Policy Context

The City of Vancouver has a reputation as a leader in sustainable urban development.



## Green Homes Program

While developing passive design strategies, it is important to keep in mind the progress the City has already made in promoting green building. For Part 9 Buildings (low-rise wood frame residential), the City has adopted the Green Homes Program.

This program sets out higher standards for all new Part 9 buildings, including:

1. Building Envelope Performance:
  - i. Windows must have maximum U-Value of 2
2. Energy Efficiency:
  - i. At least 40% of hard-wired lighting should not accept incandescent lightbulbs
  - ii. Display metres should be installed that can calculate and display consumption data
  - iii. Hot water tanks should have insulation with a minimum RSI value of 1.76

□ This toolkit offers best practices to encourage and support the use of passive design in Vancouver.





□ **Part 3 Buildings are defined as structures over 3 storeys or greater than 600m<sup>2</sup>**

- iv. Hot water tank piping should have 3 metres of insulation with a minimum RSI value of 0.35
  - v. Gas fireplaces shall have electric ignition
3. Other:
- i. Toilets shall be dual-flush design
  - ii. Each suite shall have a Heat Recovery Ventilator
  - iii. An EnerGuide Audit is required at Occupancy Permit

### Part 3 Buildings

The City is implementing several actions in line with their *Green Building Strategy* (as above) and recently enacted policies directed at energy efficiency and GHG reductions:

1. Improve and streamline enforcement of the energy utilization within the building law
2. Adopt ASHRAE 90.1 2007 as new Energy Utilization By-law
3. Decrease overall building energy use requirements by 12-15% beyond ASHRAE 90.1 2001 to meet Natural Resources Canada (NRCAN) Commercial Building Incentive Program (CBIP) requirements

### EcoDensity

The City has also implemented the EcoDensity policy, consisting of 16 actions. These actions apply only where there is a rezoning sought for a development.

1. All applicable buildings to be *either* LEED Silver with a minimum 3 optimize energy points, 1 water efficiency point and 1 stormwater management point *or* BuiltGreen BC Gold with an EnerGuide 80 rating
2. In addition, sites over two acres will require:
  - a. Business case analysis for viability of district energy systems
  - b. Layout and orientation which will reduce energy needs, facilitate passive energy solutions, incorporate urban agriculture and replicate natural systems
  - c. A sustainable transportation demand management strategy which includes requisite infrastructure
  - d. A sustainable rainwater management plan
  - e. A solid waste diversion strategy
  - f. For housing a range of unit types and tenures to enhance affordability

## Climate Neutral Network

The City of Vancouver is a signatory to the UN's *Climate Neutral Network* ([www.climateneutral.unep.org](http://www.climateneutral.unep.org)) and under this initiative has several climate action targets which include:

1. Making City operations climate neutral by 2012
2. Ensuring all new construction is carbon neutral by 2030
3. Achieving an 80% reduction in all community GHG emissions by 2050

Figure 3: Regional Timeframe Diagram

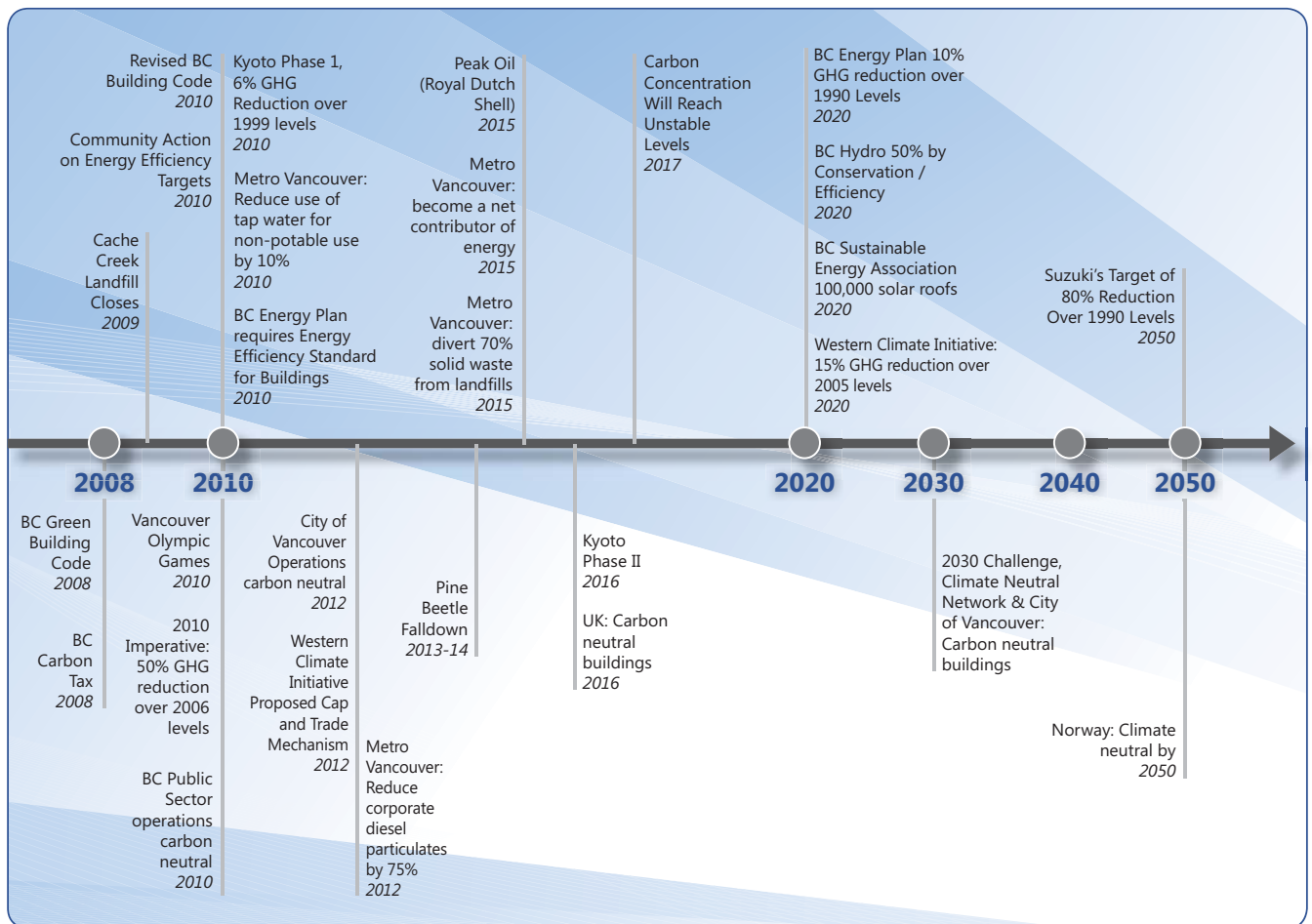

## ii. Acronyms and terms used in this report

Albedo	The ability for an object to diffuse and reflect light from the sun. Light coloured materials and paint have a high-albedo effect.
ASHRAE	American Society of Heating, Refrigeration and Air-Conditioning Engineers. ASHRAE publishes standards and guidelines relating to HVAC systems (heating, ventilation and air conditioning) and many are referenced in local building codes.
Building Envelope	The roof, walls, windows, floors and internal walls of a building
CFL	Compact Fluorescent Lights
EnerGuide	EnerGuide is the official Government of Canada mark associated with the labeling and rating of the energy consumption or energy efficiency of specific products, including homes. Homes are rated on a scale of 0-100. A rating level of 100 represents a house that is airtight, well insulated and sufficiently ventilated and requires no purchased energy.
Floor space	Floor space as used in this toolkit refers simply to the internal floor area bounded by the building envelope. However the method of measuring floor space precisely varies depending on the context-for example the Vancouver Building Bylaw contains a detailed description of the method of measurement of floor space for the purpose of submission for a Development or Building Permit and should be referred to for this purpose.
GHG Emissions	Green House Gas Emissions
Heat Island Effect	The term heat island refers to urban air and surface temperatures that are higher than in rural areas due to the displacement of trees, increased waste heat from vehicles, and warm air which is trapped between tall buildings.
HRV	Heat Recovery Ventilator
Indoor Air Quality (IAQ)	Indoor Air Quality (IAQ) refers to the composition of interior air, which has an impact on the health and comfort of building occupants. IAQ is affected by microbial contaminants (mould or bacteria), chemicals (such as carbon monoxide or radon), allergens, or any other pollutant that effects occupants.
LEED®	Leadership in Energy and Environmental Design green building rating system
Mechanical Systems	Conventional systems that use fans and pumps to heat, ventilate and condition the air.
PassivHaus	PassivHaus is a rigorous European home design standard developed in Austria and Germany, which regulates input energy to a maximum 15 kWh / m <sup>2</sup> / year – about one tenth of that in a typical new 200 m <sup>2</sup> Canadian house.
Solar Gain	(also known as <b>solar heat gain</b> or <b>passive solar gain</b> ) refers to the increase in temperature in a space, object or structure that results from solar radiation. The amount of solar gain increases with the strength of the sun, and with the ability of any intervening material to transmit or resist the radiation. In the context of passive solar building design, the aim of the designer is normally to maximise solar gain within the building in the winter (to reduce space heating demand), and to control it in summer (to minimize cooling requirements).

Thermal Bridges	A thermal bridge is any part of a construction through which heat can travel faster and with less resistance than other parts.
Thermal Comfort	Thermal comfort is defined by ASHRAE as human satisfaction with the surrounding environment, formalized in ASHRAE Standard 55. The sensations of hot and cold are not dependent on temperature alone; radiant temperature, air movement, relative humidity, activity levels and clothing levels all impact thermal comfort.
Thermal Mass	Thermal mass is the ability of a material to store heat. Thermal mass can be incorporated into a building as part of the walls and floor. High thermal mass materials include: brick, solid concrete, stone or earth.